

OCORRÊNCIA

Conforme item 13.5.4 (Inspeção em vaso de pressão), foi realizado a inspeção periódica em caráter de exame externo e interno do vaso de pressão em 25/11/2024.

Constatando-se a condição segura de operação segundo critérios da NR 13 (Norma Regulamentadora 13) publicada na portaria MTb 3214\78 M.T.E e critérios de segurança físicos da instalação sob responsabilidade técnica da empresa Alfa Service.

O relatório da inspeção será entregue ao proprietário e\ou responsável do vaso obedecendo ao item **13.3.8**

Obs. As demais recomendações e resultados dos exames seguem em relatório de inspeção posteriormente a esta inspeção periódica de segurança do equipamento

A PRÓXIMA INSPEÇÃO PERIÓDICA NÃO PODERÁ EXEDER A: NOVEMBRO DE 2026

INSPEÇÃO REALIZADA
ALFA SERVICE
Renato Rodrigues Borges
REGISTRO 1008294713D

Renato Rodrigues Borges
Eng. Mecânico
CREA: 1008294713D-GO

Segunda Feira, 25 de Novembro de 2024



DATA BOOK

CLIENTE / CUSTOMER:

MARFRIG GLOBAL FOODS S.A.

EQUIPAMENTO / EQUIPMENT:

UNIDADE COMPRESSORA PARAFUSO RWF 399

ITEM N° / SALE ORDER:

E-32107D.026-01

N° DO EQUIPAMENTO / EQUIPMENT NUMBER:

322102

DATA BOOK N° / DATA BOOK NUMBER:

148/21

ÍNDICE

- 1) MEMORIAL DE CÁLCULO
MECHANICAL CALCULATION
- 2) DESENHOS DE EQUIPAMENTOS E PLAQUETAS
DRAWINGS AND PLATES
- 3) IDENTIFICAÇÃO/CERTIFICADOS DE MATÉRIA-PRIMA
IDENTIFICATION AND CERTIFICATES OF MATERIAL
- 4) DOCUMENTOS DE SOLDA
WELDING RECORDS
- 5) RELATÓRIOS DE INSPEÇÃO / TESTES
TESTS REPORTS
- 6) TROCADOR DE CALOR
HEAT EXCHANGER
- 7) NR12



1) MEMORIAL DE CÁLCULO
MECHANICAL CALCULATION

Johnson Controls BE do Brasil Ltda

Av. Independência 2757 - Planta BE - Éden Sorocaba-SP

www.johnsoncontrols.com.br

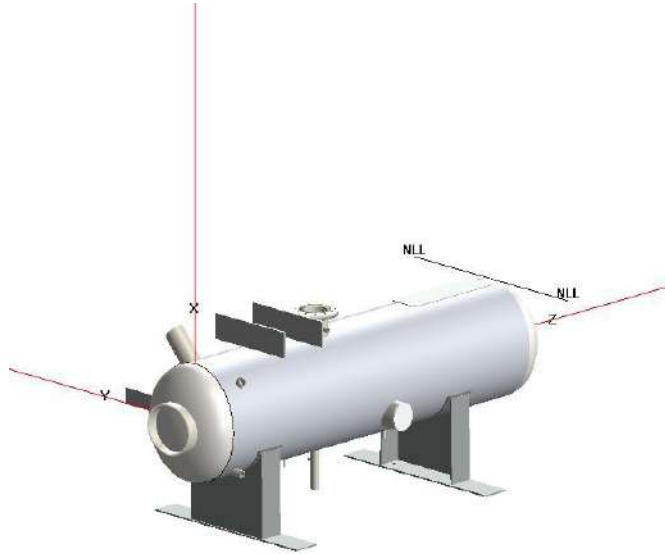

COMPRESS Pressure Vessel Design Calculations

Description/Model: Oil Separator - HOS-36

Drawing: 548E0406G31BR

Data/Revision: 03/03/2020 - Rev.0

Designed/Approved: Alexandre Almeida

Customer, as required by U-2, did not specify loadings found in UG-22 paragraphs (c), (d)(1), (e), (f), (g), (h), (i), and (j). Vessel is specified for use in non-corrosive and non-lethal refrigeration service.

Table of Contents

Deficiencies Summary	1
Nozzle Schedule	2
Nozzle Summary	3
Pressure Summary	4
Settings Summary	6
Radiography Summary	8
Thickness Summary	9
Weight Summary	10
Pneumatic Test	11
Bill of Materials	12
Engineering Notes	15
Oil Filter Vertical Load #1	16
Compressor Vertical Load #2	17
Motor Vertical Load #3	18
Ellipsoidal Head #2	19
Straight Flange on Ellipsoidal Head #2	21
Ellipsoidal Head #1	23
Separator Inlet (A)	25
Separator Outlet (B)	33
Liquid Injection (E)	38
Oil Drain (F)	41
Temperature Element (G)	44
Temperature Element (J)	47
Relief Valve (K)	50
Pump out (L)	54
Oil Relief -Oil Pump (M)	58
Oil Drain (P)	62
Heater Carrier (R)	65
Heater Carrier (R)	71
Coalescer Bleed (S)	77
Oil Outlet (T)	80

Access Opening (MW)	83
Cylinder #1	88
Oil Drain (W)	90
Still Chamber (SC)	93
Welded Cover #1	98
Saddle #1	100
Sight Glass (U)	105
Compressor #1	111
Compressor#2	113
Oil Filter Bracket #1	115
Oil Filter Bracket #2	117
Motor Support pad #1	119
Straight Flange on Ellipsoidal Head #1	121

Deficiencies Summary

No deficiencies found.

Nozzle Schedule

Specifications									
Nozzle mark	Identifier	Size	Materials		Impact Tested	Normalized	Fine Grain	Flange	Blind
A	Separator Inlet	NPS 8 Sch 40 (Std) DN 200	Nozzle	SA-106 B Smls Pipe	No	No	No	NPS 8 Class 300 SO A105	No
B	Separator Outlet	NPS 6 Sch 40 (Std) DN 150	Nozzle	SA-106 B Smls Pipe	No	No	No	N/A	No
E	Liquid Injection	NPS 0,5 Class 3000 DN 15 - Threaded Full Coupling	Nozzle	SA-105	No	No	No	N/A	No
F	Oil Drain	NPS 0,5 Class 3000 DN 15 - Threaded Full Coupling	Nozzle	SA-105	No	No	No	N/A	No
G	Temperature Element	NPS 0,75 Class 3000 DN 20 - Threaded Full Coupling	Nozzle	SA-105	No	No	No	N/A	No
J	Temperature Element	NPS 0,75 Class 3000 DN 20 - Threaded Full Coupling	Nozzle	SA-105	No	No	No	N/A	No
K	Relief Valve	NPS 2 Class 3000 DN 50 - Socket-Welding Full Coupling	Nozzle	SA-105	No	No	No	N/A	No
L	Pump out	NPS 0,75 Class 3000 DN 20 - Socket-Welding Full Coupling	Nozzle	SA-105	No	No	No	N/A	No
M	Oil Relief -Oil Pump	NPS 1 Sch 80 (XS) DN 25	Nozzle	SA-106 B Smls Pipe	No	No	No	N/A	No
MW	Access Opening	456 mm x 355 mm Elliptical Nozzle	Nozzle	SA-106 B Smls Pipe	No	No	No	N/A	No
P	Oil Drain	NPS 0,75 Sch 160 DN 20	Nozzle	SA-106 B Smls Pipe	No	No	No	N/A	No
R	Heater Carrier	NPS 1,5 XXS DN 40	Nozzle	SA-106 B Smls Pipe	No	No	No	N/A	No
R	Heater Carrier	NPS 1,5 XXS DN 40	Nozzle	SA-106 B Smls Pipe	No	No	No	N/A	No
S	Coalescer Bleed	NPS 0,75 Sch 160 DN 20	Nozzle	SA-106 B Smls Pipe	No	No	No	N/A	No
SC	Still Chamber	NPS 8 Sch 40 (Std) DN 200	Nozzle	SA-106 B Smls Pipe	No	No	No	N/A	No
	Welded Cover #1	ID = 202,72 mm x Thk = 25 mm	Welded Cover	SA-516 70	No	No	No	N/A	N/A
I	Oil Outlet	NPS 2,5 Sch 40 (Std) DN 65	Nozzle	SA-106 B Smls Pipe	No	No	No	N/A	No
U	Sight Glass	NPS 2 Sch 160 DN 50	Nozzle	SA-106 B Smls Pipe	No	No	No	N/A	No
W	Oil Drain	NPS 0,75 Sch 160 DN 20	Nozzle	SA-106 B Smls Pipe	No	No	No	N/A	No

Nozzle Summary

Dimensions												
Nozzle mark	OD (mm)	t _n (mm)	Req t _n (mm)	A ₁ ?	A ₂ ?	Shell			Reinforcement Pad		Corr (mm)	A _a /A _r (%)
						Nom t (mm)	Design t (mm)	User t (mm)	Width (mm)	t _{pad} (mm)		
<u>A</u>	219,08	8,18	7,9	Yes	Yes	12,5	6,92		N/A	N/A	0	116,4
<u>B</u>	168,27	7,11	7,11	Yes	Yes	12,5	6,92		N/A	N/A	0	123,9
<u>E</u>	28,45	3,56	1,5	Yes	Yes	12,5	N/A		N/A	N/A	0	Exempt
<u>F</u>	28,45	3,56	1,5	Yes	Yes	5,16	N/A		N/A	N/A	0	Exempt
<u>G</u>	35,05	4,06	1,5	Yes	Yes	12,5	N/A		N/A	N/A	0	Exempt
<u>J</u>	35,05	4,06	1,5	Yes	Yes	8,18	N/A		N/A	N/A	0	Exempt
<u>K</u>	73,71	6,05	1,5	Yes	Yes	12,5	N/A		N/A	N/A	0	Exempt
<u>L</u>	36,09	4,27	1,5	Yes	Yes	12,5	N/A		N/A	N/A	0	Exempt
<u>M</u>	33,4	4,55	3,38	Yes	Yes	12,5	N/A		N/A	N/A	0	Exempt
<u>MW</u>	506	25	4,7	Yes	Yes	10*	6,79		N/A	N/A	0	112,5
<u>P</u>	26,67	5,56	2,87	Yes	Yes	12,5	N/A		N/A	N/A	0	Exempt
<u>R</u>	48,26	10,16	3,68	Yes	Yes	12,5	N/A		N/A	N/A	0	Exempt
<u>R</u>	48,26	10,16	3,68	Yes	Yes	12,5	N/A		N/A	N/A	0	Exempt
<u>S</u>	26,67	5,56	2,87	Yes	Yes	12,5	N/A		N/A	N/A	0	Exempt
<u>SC</u>	219,08	8,18	7,93	Yes	Yes	12,5	6,94	12,8	N/A	N/A	0	100,4
<u>I</u>	73,02	5,16	5,16	Yes	Yes	12,5	N/A		N/A	N/A	0	Exempt
<u>U</u>	60,33	8,74	3,91	Yes	Yes	12,5	N/A		N/A	N/A	0	Exempt
<u>W</u>	26,67	5,56	2,87	Yes	Yes	12,5	N/A		N/A	N/A	0	Exempt

*Head minimum thickness after forming

Definitions	
t _n	Nozzle thickness
Req t _n	Nozzle thickness required per UG-45/UG-16 Increased for pipe to account for 12.5% pipe thickness tolerance
Nom t	Vessel wall thickness
Design t	Required vessel wall thickness due to pressure + corrosion allowance per UG-37
User t	Local vessel wall thickness (near opening)
A _a	Area available per UG-37, governing condition
A _r	Area required per UG-37, governing condition
Corr	Corrosion allowance on nozzle wall

Pressure Summary

Component Summary							
Identifier	P Design (bar)	T Design (°C)	MAWP (bar)	MAP (bar)	MDMT (°C)	MDMT Exemption	Impact Tested
Ellipsoidal Head #2	21	120	26,23	26,32	-48	Note 1	No
Straight Flange on Ellipsoidal Head #2	21	120	32,34	32,42	-48	Note 2	No
Cylinder #1	21	120	26,61	26,7	-42,88	Note 3	No
Straight Flange on Ellipsoidal Head #1	21	120	32,34	32,42	-48	Note 2	No
Ellipsoidal Head #1	21	120	26,23	26,32	-48	Note 4	No
Saddle #1	21	120	21	N/A	N/A	N/A	N/A
Compressor #1	21	120	21	N/A	N/A	N/A	N/A
Compressor#2	21	120	21	N/A	N/A	N/A	N/A
Oil Filter Bracket #1	21	120	21	N/A	N/A	N/A	N/A
Oil Filter Bracket #2	21	120	21	N/A	N/A	N/A	N/A
Motor Support pad #1	21	120	21	N/A	N/A	N/A	N/A
Separator Inlet (A)	21	120	22,71	22,71	-48	Note 5	No
Separator Outlet (B)	21	120	23,51	23,53	-105	Note 6	No
Liquid Injection (E)	21	120	38,12	38,15	-105	Note 7	No
Oil Drain (F)	21	120	156,17	156,27	-105	Note 8	No
Temperature Element (G)	21	120	38,06	38,15	-105	Note 9	No
Temperature Element (J)	21	120	79,94	79,94	-105	Note 10	No
Relief Valve (K)	21	120	30,44	30,45	-105	Note 11	No
Pump out (L)	21	120	38,12	38,15	-105	Note 12	No
Oil Relief -Oil Pump (M)	21	120	38,06	38,15	-105	Note 13	No
Access Opening (MW)	21	120	22,3	22,34	-105	Note 14	No
Oil Drain (P)	21	120	38,06	38,15	-105	Note 13	No
Heater Carrier (R)	21	120	38,07	38,15	-105	Note 15	No
Heater Carrier (R)	21	120	38,07	38,15	-105	Note 15	No
Coalescer Bleed (S)	21	120	38,06	38,15	-105	Note 13	No
Still Chamber (SC)	21	120	21,04	21,11	-105	Note 16	No
Welded Cover #1	21	120	63,52	63,6	-105	Note 17	No
Oil Outlet (T)	21	120	30,36	30,45	-105	Note 13	No
Sight Glass (U)	21	120	38,07	38,15	-105	Note 18	No
Oil Drain (W)	21	120	38,06	38,15	-105	Note 13	No

Chamber Summary	
Design MDMT	-29 °C
Rated MDMT	-42,88 °C @ 21 bar
MAWP hot & corroded	21 bar @ 120 °C
MAP cold & new	21,11 bar @ 21,11 °C
(1) The MAWP is limited due to the MAWP limit set in the Calculations tab of the Set Mode dialog. (2) This pressure chamber is not designed for external pressure.	

Notes for MDMT Rating		
Note #	Exemption	Details
1.	Straight Flange governs MDMT	
2.	Material impact test exemption temperature from Fig UCS-66M Curve B = -22,38°C Fig UCS-66.1M MDMT reduction = 27°C, (coincident ratio = 0,5496) Rated MDMT of -49,38°C is limited to -48°C by UCS-66(b)(2)	UCS-66 governing thickness = 12,5 mm
3.	Material impact test exemption temperature from Fig UCS-66M Curve B = -22,38°C Fig UCS-66.1M MDMT reduction = 20,5°C, (coincident ratio = 0,6333)	UCS-66 governing thickness = 12,5 mm
4.	Straight Flange governs MDMT	
5.	Flange rating governs: Flange rated MDMT per UCS-66(b)(1)(b) = -48°C (Coincident ratio = 0,411) Bolts rated MDMT per Fig UCS-66 note (c) = -48°C	
6.	Nozzle is impact test exempt to -105°C per UCS-66(b)(3) (coincident ratio = 0,2228).	
7.	Nozzle is impact test exempt to -105°C per UCS-66(b)(3) (coincident ratio = 0,0461).	
8.	Nozzle is impact test exempt to -105°C per UCS-66(b)(3) (coincident ratio = 0,0463).	
9.	Nozzle is impact test exempt to -105°C per UCS-66(b)(3) (coincident ratio = 0,0511).	
10.	Nozzle is impact test exempt to -105°C per UCS-66(b)(3) (coincident ratio = 0,0509).	
11.	Nozzle is impact test exempt to -105°C per UCS-66(b)(3) (coincident ratio = 0,0783).	
12.	Nozzle is impact test exempt to -105°C per UCS-66(b)(3) (coincident ratio = 0,0497).	
13.	Nozzle is impact test exempt per UCS-66(d) (NPS 4 or smaller pipe).	
14.	Nozzle is impact test exempt to -105°C per UCS-66(b)(3) (coincident ratio = 0,1879).	
15.	Nozzle is impact test exempt to -105°C per UCS-66(b)(3) (coincident ratio = 0,0284).	
16.	Nozzle is impact test exempt to -105°C per UCS-66(b)(3) (coincident ratio = 0,2556).	
17.	Head is impact test exempt to -105°C per UCS-66(b)(3) (coincident ratio = 0,3314)	
18.	Nozzle is impact test exempt to -105°C per UCS-66(b)(3) (coincident ratio = 0,0506).	

Settings Summary

COMPRESS 2020 Build 8010	
ASME Section VIII Division 1, 2019 Edition Metric	
Units	MKS
Datum Line Location	0,00 mm from left seam
Vessel Design Mode	Design Mode
Minimum thickness	1,5 mm per UG-16(b)
Design for cold shut down only	No
Design for lethal service (full radiography required)	No
User has limited MAWP to	21 bar
Design nozzles for	Design P only
Corrosion weight loss	100% of theoretical loss
UG-23 Stress Increase	1,20
Skirt/legs stress increase	1,0
Minimum nozzle projection	40 mm
Juncture calculations for $\alpha > 30$ only	Yes
Preheat P-No 1 Materials $> 1,25"$ and $\leq 1,50"$ thick	No
UG-37(a) shell tr calculation considers longitudinal stress	No
Cylindrical shells made from pipe are entered as minimum thickness	No
Nozzles made from pipe are entered as minimum thickness	No
ASME B16.9 fittings are entered as minimum thickness	No
Butt welds	Tapered per Figure UCS-66.3(a)
Disallow Appendix 1-5, 1-8 calculations under 15 psi	No
Hydro/Pneumatic Test	
Shop Pneumatic Test Pressure	1,1 times vessel MAWP [UG-100(b)]
Test liquid specific gravity	1,00
Maximum stress during test	90% of yield
Required Marking - UG-116	
UG-116(e) Radiography	None
UG-116(f) Postweld heat treatment	None
Code Cases\Interpretations	
Use Appendix 46	No
Use UG-44(b)	No
Use Code Case 2955	No
Apply interpretation VIII-1-83-66	No
Apply interpretation VIII-1-86-175	No
Apply interpretation VIII-1-01-37	No
Apply interpretation VIII-1-01-150	No
Apply interpretation VIII-1-07-50	No
Apply interpretation VIII-1-16-85	No
No UCS-66.1 MDMT reduction	No
No UCS-68(c) MDMT reduction	No

Disallow UG-20(f) exemptions	Yes
UG-22 Loadings	
UG-22(a) Internal or External Design Pressure	Yes
UG-22(b) Weight of the vessel and normal contents under operating or test conditions	Yes
UG-22(c) Superimposed static reactions from weight of attached equipment (external loads)	Yes
UG-22(d)(2) Vessel supports such as lugs, rings, skirts, saddles and legs	Yes
UG-22(f) Wind reactions	No
UG-22(f) Seismic reactions	No
UG-22(j) Test pressure and coincident static head acting during the test:	No
Note: UG-22(b),(c) and (f) loads only considered when supports are present.	
Note 2: UG-22(d)(1),(e),(f)-snow,(g),(h),(i) are not considered. If these loads are present, additional calculations must be performed.	

License Information	
Company Name	Johnson Controls Be do Brasil Ltda.
License	Commercial
License Key ID	23460
Support Expires	June 26, 2021

Radiography Summary

UG-116 Radiography							
Component	Longitudinal Seam		Left Circumferential Seam		Right Circumferential Seam		Mark
	Category (Fig UW-3)	Radiography / Joint Type	Category (Fig UW-3)	Radiography / Joint Type	Category (Fig UW-3)	Radiography / Joint Type	
Ellipsoidal Head #2	N/A	Seamless No RT	N/A	N/A	B	None UW-11(c) / Type 1	None
Cylinder #1	A	None UW-11(c) / Type 1	B	None UW-11(c) / Type 1	B	None UW-11(c) / Type 1	None
Welded Cover #1	N/A	Seamless No RT	B	UW-11(a)(4) exempt	N/A	N/A	N/A
Ellipsoidal Head #1	N/A	Seamless No RT	B	None UW-11(c) / Type 1	N/A	N/A	None
Nozzle	Longitudinal Seam		Nozzle to Vessel Circumferential Seam		Nozzle free end Circumferential Seam		
Access Opening (MW)	N/A	Seamless No RT	D	N/A / Type 7	N/A	N/A	N/A
Separator Inlet (A)	N/A	Seamless No RT	D	N/A / Type 7	C	N/A / Type 4	N/A
Temperature Element (J)	N/A	Seamless No RT	D	N/A / Type 7	N/A	N/A	N/A
Separator Outlet (B)	N/A	Seamless No RT	D	N/A / Type 7	N/A	N/A	N/A
Liquid Injection (E)	N/A	Seamless No RT	D	N/A / Type 7	N/A	N/A	N/A
Temperature Element (G)	N/A	Seamless No RT	D	N/A / Type 7	N/A	N/A	N/A
Relief Valve (K)	N/A	Seamless No RT	D	N/A / Type 7	B	N/A / Type 6	N/A
Pump out (L)	N/A	Seamless No RT	D	N/A / Type 7	B	N/A / Type 6	N/A
Oil Relief -Oil Pump (M)	N/A	Seamless No RT	D	N/A / Type 7	N/A	N/A	N/A
Oil Drain (P)	N/A	Seamless No RT	D	N/A / Type 7	N/A	N/A	N/A
Heater Carrier (R)	N/A	Seamless No RT	D	N/A / Type 7	N/A	N/A	N/A
Heater Carrier (R)	N/A	Seamless No RT	D	N/A / Type 7	N/A	N/A	N/A
Coalescer Bleed (S)	N/A	Seamless No RT	D	N/A / Type 7	N/A	N/A	N/A
Oil Outlet (T)	N/A	Seamless No RT	D	N/A / Type 7	N/A	N/A	N/A
Oil Drain (F)	N/A	Seamless No RT	D	N/A / Type 7	N/A	N/A	N/A
Oil Drain (W)	N/A	Seamless No RT	D	N/A / Type 7	N/A	N/A	N/A
Sight Glass (U)	N/A	Seamless No RT	D	N/A / Type 7	N/A	N/A	N/A
Still Chamber (SC)	N/A	Seamless No RT	D	N/A / Type 7	B	UW-11(a)(4) exempt	N/A
Nozzle Flange	Longitudinal Seam		Flange Face		Nozzle to Flange Circumferential Seam		
ASME B16.5/16.47 flange attached to Separator Inlet (A)	N/A	Seamless No RT	N/A	N/A / Gasketed	C	N/A / Type 4	N/A
UG-116(e) Required Marking: None							

Thickness Summary

Component Data								
Component Identifier	Material	Diameter (mm)	Length (mm)	Nominal t (mm)	Design t (mm)	Total Corrosion (mm)	Joint E	Load
Ellipsoidal Head #2	SA-516 70	889,4 ID	232,35	10*	8,01	0	0,85	Internal
Straight Flange on Ellipsoidal Head #2	SA-516 70	889,4 ID	38	12,5	8,08	0	0,85	Internal
Cylinder #1	SA-516 70	914,4 OD	3.505,2	12,5	9,9	0	0,70	Internal
Straight Flange on Ellipsoidal Head #1	SA-516 70	889,4 ID	38	12,5	8,08	0	0,85	Internal
Ellipsoidal Head #1	SA-516 70	889,4 ID	232,35	10*	8,01	0	0,85	Internal
Welded Cover #1	SA-516 70	202,72 ID	25	25	14,39	0	1,00	Internal

*Head minimum thickness after forming

Definitions	
Nominal t	Vessel wall nominal thickness
Design t	Required vessel thickness due to governing loading + corrosion
Joint E	Longitudinal seam joint efficiency
Load	
Internal	Circumferential stress due to internal pressure governs
External	External pressure governs
Wind	Combined longitudinal stress of pressure + weight + wind governs
Seismic	Combined longitudinal stress of pressure + weight + seismic governs

Weight Summary

Weight (kg) Contributed by Vessel Elements											
Component	Metal New*	Metal Corroded	Insulation	Insulation Supports	Lining	Piping + Liquid	Operating Liquid		Test Liquid		Surface Area m ²
							New	Corroded	New	Corroded	
Ellipsoidal Head #2	71,3	71,3	0	0	0	0	120,8	120,8	120,8	120,8	0,91
Cylinder #1	960,9	960,9	0	0	0	0	2.184,5	2.184,5	2.192,6	2.192,6	9,95
Ellipsoidal Head #1	83,9	83,9	0	0	0	0	115,6	115,6	115,6	115,6	1,11
Saddle #1	322,1	322,1	0	0	0	0	0	0	0	0	4,64
TOTAL:	1.438,2	1.438,2	0	0	0	0	2.420,8	2.420,8	2.429	2.429	16,61

*Shells with attached nozzles have weight reduced by material cut out for opening.

Weight (kg) Contributed by Attachments										
Component	Body Flanges		Nozzles & Flanges		Packed Beds	Trays	Tray Supports	Rings & Clips	Vertical Loads	Surface Area m ²
	New	Corroded	New	Corroded						
Ellipsoidal Head #2	0	0	24	24	0	0	0	0	0	0,06
Cylinder #1	0	0	74,7	74,7	0	0	0	81,1	4.805	1,96
Ellipsoidal Head #1	0	0	0	0	0	0	0	0	0	0
TOTAL:	0	0	98,7	98,7	0	0	0	81,1	4.805	2,02

Vessel Totals		
	New	Corroded
Operating Weight (kg)	8.844	8.844
Empty Weight (kg)	6.423	6.423
Test Weight (kg)	8.852	8.852
Surface Area (m ²)	18,64	-
Capacity** (liters)	2.409	2.409

**The vessel capacity does not include volume of nozzle, piping or other attachments.

Vessel Lift Condition	
Vessel Lift Weight, New (kg)	6.423
Center of Gravity from Datum (mm)	1.764,7

Pneumatic Test

Horizontal shop pneumatic test based on MAWP per UG-100(b)

$$\begin{aligned} \text{Gauge pressure at } 21,11^{\circ}\text{C} &= 1,1 \cdot \text{MAWP} \cdot \text{LSR} \\ &= 1,1 \cdot 21 \cdot 1 \\ &= 23,1 \text{ bar} \end{aligned}$$

Horizontal shop pneumatic test				
Identifier	Local test pressure (bar)	Test liquid static head (bar)	UG-100(b) stress ratio	UG-100(b) pressure factor
Ellipsoidal Head #2 (1)	23,21	0,11	1	1,10
Straight Flange on Ellipsoidal Head #2	23,21	0,11	1	1,10
Cylinder #1	23,21	0,11	1	1,10
Straight Flange on Ellipsoidal Head #1	23,21	0,11	1	1,10
Ellipsoidal Head #1	23,21	0,11	1	1,10
Welded Cover #1	23,19	0,09	1	1,10
Access Opening (MW)	23,18	0,08	1	1,10
Coalescer Bleed (S)	23,23	0,13	1	1,10
Heater Carrier (R)	23,2	0,1	1	1,10
Heater Carrier (R)	23,2	0,1	1	1,10
Liquid Injection (E)	23,15	0,05	1	1,10
Oil Drain (F)	23,22	0,12	1	1,10
Oil Drain (P)	23,22	0,12	1	1,10
Oil Drain (W)	23,22	0,12	1	1,10
Oil Outlet (T)	23,24	0,14	1	1,10
Oil Relief -Oil Pump (M)	23,21	0,11	1	1,10
Pump out (L)	23,14	0,04	1	1,10
Relief Valve (K)	23,13	0,03	1	1,10
Separator Inlet (A)	23,12	0,02	1	1,10
Separator Outlet (B)	23,14	0,04	1	1,10
Sight Glass (U)	23,2	0,1	1	1,10
Still Chamber (SC)	23,19	0,09	1	1,10
Temperature Element (G)	23,21	0,11	1	1,10
Temperature Element (J)	23,12	0,02	1	1,10

(1) Ellipsoidal Head #2 limits the UG-100(b) stress ratio.
(2) The zero degree angular position is assumed to be up, and the test liquid height is assumed to the top-most flange.

The field test condition has not been investigated.

The test temperature of 21,11 °C is warmer than the minimum required temperature of -25,88 °C so the brittle fracture provision of UG-100(c) has been met.

Bill of Materials

Heads / Covers						
Item #	Type	Material	Thk [mm]	Dia. [mm]	Wt. [kg] (ea.)	Qty
H1	Ellipsoidal Head	SA-516 70	10 (min.)	889,4 ID	83,9	2
H2	Welded Cover	SA-516 70	25	202,72 ID	7,4	1

Shells							
Item #	Type	Material	Thk [mm]	Dia. [mm]	Length [mm]	Wt. [kg] (ea.)	Qty
S1	Cylinder	SA-516 70	12,5	914,4 OD	3.505	972,4	1

Nozzles							
Item #	Type	Material	NPS	Thk [mm]	Dia. [mm]	Length [mm]	Wt. [kg]
Noz1	Nozzle	SA-106 B Smls Pipe	-	25	456 ID	105	24
Noz2	Nozzle	SA-106 B Smls Pipe	NPS 8 Sch 40 (Std) DN 200	8,18	202,72 ID	441	18,7
Noz3	Nozzle	SA-106 B Smls Pipe	NPS 6 Sch 40 (Std) DN 150	7,11	154,05 ID	366	10,3
Noz4	Nozzle	SA-106 B Smls Pipe	NPS 1 Sch 80 (XS) DN 25	4,55	24,31 ID	147	0,5
Noz5	Nozzle	SA-106 B Smls Pipe	NPS 0,75 Sch 160 DN 20	5,56	15,54 ID	427	1,2
Noz6	Nozzle	SA-106 B Smls Pipe	NPS 1,5 XXS DN 40	10,16	27,94 ID	407	3,9
Noz7	Nozzle	SA-106 B Smls Pipe	NPS 2,5 Sch 40 (Std) DN 65	5,16	62,71 ID	353	3
Noz8	Nozzle	SA-106 B Smls Pipe	NPS 2 Sch 160 DN 50	8,74	42,85 ID	205	2,3

Nozzles - Couplings							
Item #	Type	Material	Dia. [mm]	Socket Depth J [mm]	Bore Diameter D [mm]	Length [mm]	Qty
C1	NPS 0,75 Class 3000 DN 20 - Threaded Full Coupling	SA-105	35,05 OD	-	-	50,8	2
C2	NPS 0,5 Class 3000 DN 15 - Threaded Full Coupling	SA-105	28,45 OD	-	-	47,75	2
C3	NPS 2 Class 3000 DN 50 - Socket-Welding Full Coupling	SA-105	73,71 OD	15,75	53,26	50,55	1
C4	NPS 0,75 Class 3000 DN 20 - Socket-Welding Full Coupling	SA-105	36,09 OD	12,7	21,69	35,05	1

Flanges						
Item #	Type	Material	NPS	Dia. [mm]	Wt. [kg] (ea.)	Qty
AF1	ASME B16.5 Slip On - Class 300	A105	8	381 x 221,49	26,3	1

Fasteners				
Item #	Description	Material	Length [mm]	Qty
FB1	7/8" coarse bolt	SA-193 B7 Bolt <= 64	121	12
SB1	M20 x 2.5	Saddle bolt material	-	4

All listed flange bolts require associated nuts and washers in accordance with Division 1, UCS-11.

Plates				
Item #	Material	Thk [mm]	Wt. [kg]	Qty [m^2]
Plate1	SA-516-70	12,5	322,4	3,3
Plate1 - Note: Applies to saddle wear plate, saddle base plate, saddle web plate				
Plate2	SA-516 70	813	63,7	0,01
Plate2 - Note: Applies to clip plates				
Plate3	SA-516 70	127	4,8	0,0049
Plate3 - Note: Applies to clip plates				
Plate4	SA-516 70	279	12,6	0,0058
Plate4 - Note: Applies to clip plates				

Engineering Notes

The "SC" nozzle calculation was simply to show your welded cover.

The lifting lugs were calculated separately.

Oil Filter Vertical Load #1

ASME Section VIII Division 1, 2019 Edition Metric	
Inputs	
Load Orientation	Vertical Load
Position from datum	457 mm
Direction Angle	0,00°
Magnitude of Force	105 kg
Loading Conditions	
Present When Operating	Yes
Included in Vessel Lift Weight	Yes
Present When Vessel is Empty	Yes
Present During Test	Yes

Compressor Vertical Load #2

ASME Section VIII Division 1, 2019 Edition Metric	
Inputs	
Load Orientation	Vertical Load
Position from datum	885 mm
Direction Angle	0,00°
Magnitude of Force	2.500 kg
Loading Conditions	
Present When Operating	Yes
Included in Vessel Lift Weight	Yes
Present When Vessel is Empty	Yes
Present During Test	Yes

Motor Vertical Load #3

ASME Section VIII Division 1, 2019 Edition Metric	
Inputs	
Load Orientation	Vertical Load
Position from datum	2.900 mm
Direction Angle	0,00°
Magnitude of Force	2.200 kg
Loading Conditions	
Present When Operating	Yes
Included in Vessel Lift Weight	Yes
Present When Vessel is Empty	Yes
Present During Test	Yes

Ellipsoidal Head #2

ASME Section VIII Division 1, 2019 Edition Metric				
Component		Ellipsoidal Head		
Material		SA-516 70 (II-D Metric p. 20, ln. 33)		
Attached To		Cylinder #1		
Impact Tested	Normalized	Fine Grain Practice	PWHT	Maximize MDMT/ No MAWP
No	No	No	No	No
		Design Pressure (bar)	Design Temperature (°C)	Design MDMT (°C)
Internal		21	120	-29
Static Liquid Head				
Condition		P_s (bar)	H_s (mm)	SG
Operating		0,09	901,7	1
Test horizontal		0,11	1.081,61	1
Dimensions				
Inner Diameter		889,4 mm		
Head Ratio		2		
Minimum Thickness		10 mm		
Corrosion	Inner	0 mm		
	Outer	0 mm		
Length L_{sf}		38 mm		
Nominal Thickness t_{sf}		12,5 mm		
Weight and Capacity				
		Weight (kg)¹	Capacity (liters)¹	
New		71,33	115,7	
Corroded		71,33	115,7	
Radiography				
Category A joints		Seamless No RT		
Head to shell seam		None UW-11(c) Type 1		

¹ includes straight flange

Results Summary	
Governing condition	internal pressure
Minimum thickness per UG-16	1,5 mm + 0 mm = 1,5 mm
Design thickness due to internal pressure (t)	8,01 mm
Maximum allowable working pressure (MAWP)	26,23 bar
Maximum allowable pressure (MAP)	26,32 bar
Straight Flange governs MDMT	-48°C

Design thickness for internal pressure, (Corroded at 120 °C) UG-32(c)(1)

$$\begin{aligned}
 t &= P \cdot D / (2 \cdot S \cdot E - 0,2 \cdot P) + \text{Corrosion} \\
 &= 21,09 \cdot 889,4 / (2 \cdot 1.380 \cdot 0,85 - 0,2 \cdot 21,09) + 0 \\
 &= \a href="#">8,01 \text{ mm}
 \end{aligned}$$

Maximum allowable working pressure, (Corroded at 120 °C) UG-32(c)(1)

$$\begin{aligned} P &= 2 \cdot S \cdot E \cdot t / (D + 0,2 \cdot t) - P_s \\ &= 2 \cdot 1.380 \cdot 0,85 \cdot 10 / (889,4 + 0,2 \cdot 10) - 0,09 \\ &= \underline{26,23} \text{ bar} \end{aligned}$$

Maximum allowable pressure, (New at 21,11 °C) UG-32(c)(1)

$$\begin{aligned} P &= 2 \cdot S \cdot E \cdot t / (D + 0,2 \cdot t) - P_s \\ &= 2 \cdot 1.380 \cdot 0,85 \cdot 10 / (889,4 + 0,2 \cdot 10) - 0 \\ &= \underline{26,32} \text{ bar} \end{aligned}$$

% Extreme fiber elongation - UCS-79(d)

$$\begin{aligned} EFE &= (75 \cdot t / R_f) \cdot (1 - R_f / R_o) \\ &= (75 \cdot 12,5 / 157,45) \cdot (1 - 157,45 / \text{infinity}) \\ &= 5,9543\% \end{aligned}$$

The extreme fiber elongation exceeds 5 percent. Heat treatment per UCS-56 may be required. See UCS-79(d)(2)(d) or (e).

Straight Flange on Ellipsoidal Head #2

ASME Section VIII Division 1, 2019 Edition Metric				
Component		Cylinder		
Material		SA-516 70 (II-D Metric p. 20, ln. 33)		
Impact Tested	Normalized	Fine Grain Practice	PWHT	Maximize MDMT/ No MAWP
No	No	No	No	No
		Design Pressure (bar)	Design Temperature (°C)	Design MDMT (°C)
Internal		21	120	-29
Static Liquid Head				
Condition		P_s (bar)	H_s (mm)	SG
Operating		0,09	901,7	1
Test horizontal		0,11	1.081,61	1
Dimensions				
Inner Diameter		889,4 mm		
Length		38 mm		
Nominal Thickness		12,5 mm		
Corrosion	Inner	0 mm		
	Outer	0 mm		
Weight and Capacity				
		Weight (kg)	Capacity (liters)	
New		10,54	23,61	
Corroded		10,54	23,61	
Radiography				
Longitudinal seam		Seamless No RT		
Right Circumferential seam		None UW-11(c) Type 1		

Results Summary	
Governing condition	Internal pressure
Minimum thickness per UG-16	1,5 mm + 0 mm = 1,5 mm
Design thickness due to internal pressure (t)	8,08 mm
Maximum allowable working pressure (MAWP)	32,34 bar
Maximum allowable pressure (MAP)	32,42 bar
Rated MDMT	-48 °C

UCS-66 Material Toughness Requirements	
Governing thickness, $t_g =$	12,5 mm
Exemption temperature from Fig UCS-66M Curve B =	-22,38°C
$t_r = 21,09 \cdot 444,7 / (1.380 \cdot 0,85 - 0.6 \cdot 21,09) =$	8,08 mm
Stress ratio = $t_r \cdot E^* / (t_n - c) = 8,08 \cdot 0,85 / (12,5 - 0) =$	0,5496
Reduction in MDMT, T_R from Fig UCS-66.1M =	27°C
MDMT = $\max[\text{MDMT} - T_R, -48] = \max[-22,38 - 27, -48] =$	-48°C
Material is exempt from impact testing at the Design MDMT of -29°C.	

Design thickness, (at 120 °C) UG-27(c)(1)

$$\begin{aligned}
 t &= P \cdot R / (S \cdot E - 0,60 \cdot P) + \text{Corrosion} \\
 &= 21,09 \cdot 444,7 / (1.380 \cdot 0,85 - 0,60 \cdot 21,09) + 0 \\
 &= \underline{8,08} \text{ mm}
 \end{aligned}$$

Maximum allowable working pressure, (at 120 °C) UG-27(c)(1)

$$\begin{aligned}
 P &= S \cdot E \cdot t / (R + 0,60 \cdot t) - P_s \\
 &= 1.380 \cdot 0,85 \cdot 12,5 / (444,7 + 0,60 \cdot 12,5) - 0,09 \\
 &= \underline{32,34} \text{ bar}
 \end{aligned}$$

Maximum allowable pressure, (at 21,11 °C) UG-27(c)(1)

$$\begin{aligned}
 P &= S \cdot E \cdot t / (R + 0,60 \cdot t) \\
 &= 1.380 \cdot 0,85 \cdot 12,5 / (444,7 + 0,60 \cdot 12,5) \\
 &= \underline{32,42} \text{ bar}
 \end{aligned}$$

% Extreme fiber elongation - UCS-79(d)

$$\begin{aligned}
 \text{EFE} &= (50 \cdot t / R_f) \cdot (1 - R_f / R_o) \\
 &= (50 \cdot 12,5 / 450,95) \cdot (1 - 450,95 / \text{infinity}) \\
 &= 1,386\%
 \end{aligned}$$

The extreme fiber elongation does not exceed 5%.

Ellipsoidal Head #1

ASME Section VIII Division 1, 2019 Edition Metric				
Component		Ellipsoidal Head		
Material		SA-516 70 (II-D Metric p. 20, ln. 33)		
Attached To		Cylinder #1		
Impact Tested	Normalized	Fine Grain Practice	PWHT	Maximize MDMT/ No MAWP
No	No	No	No	No
		Design Pressure (bar)	Design Temperature (°C)	Design MDMT (°C)
Internal		21	120	-29
Static Liquid Head				
Condition		P_s (bar)	H_s (mm)	SG
Operating		0,09	901,7	1
Test horizontal		0,11	1.081,61	1
Dimensions				
Inner Diameter		889,4 mm		
Head Ratio		2		
Minimum Thickness		10 mm		
Corrosion	Inner	0 mm		
	Outer	0 mm		
Length L_{sf}		38 mm		
Nominal Thickness t_{sf}		12,5 mm		
Weight and Capacity				
		Weight (kg)¹	Capacity (liters)¹	
New		83,94	115,7	
Corroded		83,94	115,7	
Radiography				
Category A joints		Seamless No RT		
Head to shell seam		None UW-11(c) Type 1		

¹ includes straight flange

Results Summary	
Governing condition	internal pressure
Minimum thickness per UG-16	1,5 mm + 0 mm = 1,5 mm
Design thickness due to internal pressure (t)	<u>8,01</u> mm
Maximum allowable working pressure (MAWP)	<u>26,23</u> bar
Maximum allowable pressure (MAP)	<u>26,32</u> bar
<u>Straight Flange</u> governs MDMT	-48°C

Design thickness for internal pressure, (Corroded at 120 °C) UG-32(c)(1)

$$\begin{aligned}
 t &= P \cdot D / (2 \cdot S \cdot E - 0,2 \cdot P) + \text{Corrosion} \\
 &= 21,09 \cdot 889,4 / (2 \cdot 1.380 \cdot 0,85 - 0,2 \cdot 21,09) + 0 \\
 &= \underline{8,01} \text{ mm}
 \end{aligned}$$

Maximum allowable working pressure, (Corroded at 120 °C) UG-32(c)(1)

$$\begin{aligned} P &= 2 \cdot S \cdot E \cdot t / (D + 0,2 \cdot t) - P_s \\ &= 2 \cdot 1.380 \cdot 0,85 \cdot 10 / (889,4 + 0,2 \cdot 10) - 0,09 \\ &= \underline{26,23} \text{ bar} \end{aligned}$$

Maximum allowable pressure, (New at 21,11 °C) UG-32(c)(1)

$$\begin{aligned} P &= 2 \cdot S \cdot E \cdot t / (D + 0,2 \cdot t) - P_s \\ &= 2 \cdot 1.380 \cdot 0,85 \cdot 10 / (889,4 + 0,2 \cdot 10) - 0 \\ &= \underline{26,32} \text{ bar} \end{aligned}$$

% Extreme fiber elongation - UCS-79(d)

$$\begin{aligned} EFE &= (75 \cdot t / R_f) \cdot (1 - R_f / R_o) \\ &= (75 \cdot 12,5 / 157,45) \cdot (1 - 157,45 / \text{infinity}) \\ &= 5,9543\% \end{aligned}$$

The extreme fiber elongation exceeds 5 percent. Heat treatment per UCS-56 may be required. See UCS-79(d)(2)(d) or (e).

Separator Inlet (A)

ASME Section VIII Division 1, 2019 Edition Metric

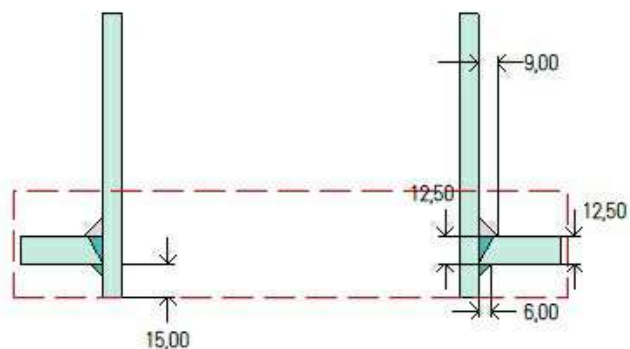

Note: round inside edges per UG-76(c)

Location and Orientation

Located on	Cylinder #1
Orientation	0°
Nozzle center line offset to datum line	1.371,6 mm
End of nozzle to shell center	636,91 mm
Offset from center, Lo	51 mm
Passes through a Category A joint	No

Nozzle

Description	NPS 8 Sch 40 (Std) DN 200
Access opening	No
Material specification	SA-106 B Smls Pipe (II-D Metric p. 16, In. 10)
Inside diameter, new	202,72 mm
Pipe nominal wall thickness	8,18 mm
Pipe minimum wall thickness ¹	7,16 mm
Corrosion allowance	0 mm
Opening chord length	204,12 mm
Projection available outside vessel, Lpr	171,53 mm
Internal projection, h _{new}	15 mm
Projection available outside vessel to flange face, Lf	179,71 mm
Local vessel minimum thickness	12,5 mm
Liquid static head included	0 bar
Longitudinal joint efficiency	1

Welds

Inner fillet, Leg ₄₁	9 mm
Lower fillet, Leg ₄₃	6 mm
Nozzle to vessel groove weld	12,5 mm

¹Pipe minimum thickness = nominal thickness times pipe tolerance factor of 0,875.

ASME B16.5-2013 Flange	
Description	NPS 8 Class 300 SO A105
Bolt Material	SA-193 B7 Bolt <= 64 (II-D Metric p. 398, In. 32)
Blind included	No
Rated MDMT	-48°C
Liquid static head	0 bar
MAWP rating	46 bar @ 120°C
MAP rating	51,1 bar @ 21,11°C
Hydrotest rating	77 bar @ 21,11°C
External fillet weld leg (UW-21)	12 mm (11,45 mm min)
Internal fillet weld leg (UW-21)	8 mm (6 mm min)
PWHT performed	No
Produced to Fine Grain Practice and Supplied in Heat Treated Condition	No
Impact Tested	No
UW-21 Flange Welds	
$X_{\min} = \min[1,4 \cdot t_n, g_0] = [1,4 \cdot 8,18, 19,43] =$	11,45 mm
External Leg _{min} = $X_{\min} + C_o / 0,7 = 11,45 + 0 / 0,7 =$	11,45 mm
Internal Leg _{min} = $\min[t_n, 6 \text{ mm} + C_i / 0,7] = \min[8,18, 6 + 0 / 0,7] =$	6 mm
Notes	
Flange rated MDMT per UCS-66(b)(1)(b) = -48°C (Coincident ratio = 0,411) Bolts rated MDMT per Fig UCS-66 note (c) = -48°C	

UCS-66 Material Toughness Requirements Nozzle	
$t_r = 21 \cdot 101,36 / (1,180 \cdot 1 - 0,6 \cdot 21) =$	1,82 mm
Stress ratio = $t_r \cdot E^* / (t_n - c) = 1,82 \cdot 1 / (7,16 - 0) =$	0,2548
Stress ratio $\leq 0,35$, MDMT per UCS-66(b)(3) =	-105°C
Material is exempt from impact testing at the Design MDMT of -29°C.	

Reinforcement Calculations for Internal Pressure

UG-37 Area Calculation Summary (cm ²)							UG-45 Summary (mm)	
For P = 21 bar @ 120 °C The opening is adequately reinforced							The nozzle passes UG-45	
A required	A available	A ₁	A ₂	A ₃	A ₅	A welds	t _{req}	t _{min}
7,1397	23,5639	18,2425	2,2226	2,0981	-	1,0006	6,92	7,16

UG-41 Weld Failure Path Analysis Summary
The nozzle is exempt from weld strength calculations per UW-15(b)(1)

UW-16 Weld Sizing Summary			
Weld description	Required weld throat size (mm)	Actual weld throat size (mm)	Status
Nozzle to shell fillet (Leg ₄₁)	5,73	6,3	weld size is adequate

Calculations for internal pressure 21 bar @ 120 °C

Parallel Limit of reinforcement per UG-40

$$\begin{aligned}
 L_R &= \text{MAX}(d, R_n + (t_n - C_n) + (t - C)) \\
 &= \text{MAX}(204,12, 102,06 + (8,18 - 0) + (12,5 - 0)) \\
 &= 204,12 \text{ mm}
 \end{aligned}$$

Outer Normal Limit of reinforcement per UG-40

$$\begin{aligned}
 L_H &= \text{MIN}(2,5*(t - C), 2,5*(t_n - C_n) + t_e) \\
 &= \text{MIN}(2,5*(12,5 - 0), 2,5*(8,18 - 0) + 0) \\
 &= 20,45 \text{ mm}
 \end{aligned}$$

Inner Normal Limit of reinforcement per UG-40

$$\begin{aligned}
 L_I &= \text{MIN}(h, 2,5*(t - C), 2,5*(t_i - C_n - C)) \\
 &= \text{MIN}(15, 2,5*(12,5 - 0), 2,5*(8,18 - 0 - 0)) \\
 &= 15 \text{ mm}
 \end{aligned}$$

Nozzle required thickness per UG-27(c)(1)

$$\begin{aligned}
 t_{rn} &= P * R_n / (S_n * E - 0,6 * P) \\
 &= 21,0003 * 101,36 / (1,180 * 1 - 0,6 * 21,0003) \\
 &= 1,82 \text{ mm}
 \end{aligned}$$

Required thickness t_r from UG-37(a)

$$\begin{aligned}
 t_r &= P * R_o / (S * E + 0,4 * P) \\
 &= 21,0003 * 457,2 / (1,380 * 1 + 0,4 * 21,0003) \\
 &= 6,92 \text{ mm}
 \end{aligned}$$

Area required per UG-37(c)

Allowable stresses: S_n = 1.203,265, S_v = 1.407,208 kgf/cm²

$$f_{r1} = \text{lesser of } 1 \text{ or } S_n / S_v = 0,8551$$

$$f_{r2} = \text{lesser of } 1 \text{ or } S_n / S_v = 0,8551$$

$$\begin{aligned}
 A &= d * t_r * F + 2 * t_n * t_r * F * (1 - f_{r1}) \\
 &= (204,12 * 6,92 * 0,5 + 2 * 8,18 * 6,92 * 0,5 * (1 - 0,8551)) / 100 \\
 &= [7,1397](#) \text{ cm}^2
 \end{aligned}$$

Area available from FIG. UG-37.1

$A_1 = \text{larger of the following} = 18,2425 \text{ cm}^2$

$$\begin{aligned} &= d(E_1 t - F t_r) - 2 t_n (E_1 t - F t_r) (1 - f_{r1}) \\ &= (204,12 * (1 * 12,5 - 0,5 * 6,92) - 2 * 8,18 * (1 * 12,5 - 0,5 * 6,92) * (1 - 0,8551)) / 100 \\ &= 18,2425 \text{ cm}^2 \\ &= 2 * (t + t_n) (E_1 t - F t_r) - 2 t_n (E_1 t - F t_r) (1 - f_{r1}) \\ &= (2 * (12,5 + 8,18) * (1 * 12,5 - 0,5 * 6,92) - 2 * 8,18 * (1 * 12,5 - 0,5 * 6,92) * (1 - 0,8551)) / 100 \\ &= 3,5252 \text{ cm}^2 \end{aligned}$$

$A_2 = \text{smaller of the following} = 2,2226 \text{ cm}^2$

$$\begin{aligned} &= 5 * (t_n - t_{rn}) f_{r2} t \\ &= (5 * (8,18 - 1,82) * 0,8551 * 12,5) / 100 \\ &= 3,3961 \text{ cm}^2 \\ &= 5 * (t_n - t_{rn}) f_{r2} t_n \\ &= (5 * (8,18 - 1,82) * 0,8551 * 8,18) / 100 \\ &= 2,2226 \text{ cm}^2 \end{aligned}$$

$A_3 = \text{smaller of the following} = 2,0981 \text{ cm}^2$

$$\begin{aligned} &= 5 t_i f_{r2} \\ &= (5 * 12,5 * 8,18 * 0,8551) / 100 \\ &= 4,3711 \text{ cm}^2 \\ &= 5 t_i t_i f_{r2} \\ &= (5 * 8,18 * 8,18 * 0,8551) / 100 \\ &= 2,86 \text{ cm}^2 \\ &= 2 h t_i f_{r2} \\ &= (2 * 15 * 8,18 * 0,8551) / 100 \\ &= 2,0981 \text{ cm}^2 \end{aligned}$$

$$\begin{aligned} A_{41} &= \text{Leg}^2 f_{r2} \\ &= (9^2 * 0,8551) / 100 \\ &= 0,6929 \text{ cm}^2 \end{aligned}$$

$$\begin{aligned} A_{43} &= \text{Leg}^2 f_{r2} \\ &= (6^2 * 0,8551) / 100 \\ &= 0,3077 \text{ cm}^2 \end{aligned}$$

$$\begin{aligned} \text{Area} &= A_1 + A_2 + A_3 + A_{41} + A_{43} \\ &= 18,2425 + 2,2226 + 2,0981 + 0,6929 + 0,3077 \\ &= 23,5639 \text{ cm}^2 \end{aligned}$$

As Area \geq A the reinforcement is adequate.

UW-16(c) Weld Check

Fillet weld: t_{\min} = lesser of 19 mm or t_n or $t = 8,18$ mm

$t_{c(\min)}$ = lesser of 6 mm or $0,7 * t_{\min} = 5,73$ mm

$t_{c(\text{actual})} = 0,7 * \text{Leg} = 0,7 * 9 = 6,3$ mm

The fillet weld size is satisfactory.

Weld strength calculations are not required for this detail which conforms to Fig. UW-16.1, sketch (c-e).

UG-45 Nozzle Neck Thickness Check

$$\begin{aligned}
 t_{a \text{ UG-27}} &= P \cdot R_n / (S_n \cdot E - 0,6 \cdot P) + \text{Corrosion} \\
 &= 21,0003 \cdot 101,36 / (1.180 \cdot 1 - 0,6 \cdot 21,0003) + 0 \\
 &= 1,82 \text{ mm}
 \end{aligned}$$

$$\begin{aligned}
 t_a &= \max[t_{a \text{ UG-27}}, t_{a \text{ UG-22}}] \\
 &= \max[1,82, 0] \\
 &= 1,82 \text{ mm}
 \end{aligned}$$

$$\begin{aligned}
 t_{b1} &= P \cdot R_o / (S \cdot E + 0,4 \cdot P) + \text{Corrosion} \\
 &= 21,0003 \cdot 457,2 / (1.380 \cdot 1 + 0,4 \cdot 21,0003) + 0 \\
 &= 6,92 \text{ mm}
 \end{aligned}$$

$$\begin{aligned}
 t_{b1} &= \max[t_{b1}, t_{b \text{ UG16}}] \\
 &= \max[6,92, 1,5] \\
 &= 6,92 \text{ mm}
 \end{aligned}$$

$$\begin{aligned}
 t_b &= \min[t_{b3}, t_{b1}] \\
 &= \min[7,16, 6,92] \\
 &= 6,92 \text{ mm}
 \end{aligned}$$

$$\begin{aligned}
 t_{\text{UG-45}} &= \max[t_a, t_b] \\
 &= \max[1,82, 6,92] \\
 &= \underline{6,92} \text{ mm}
 \end{aligned}$$

Available nozzle wall thickness new, $t_n = 0,875 \cdot 8,18 = 7,16 \text{ mm}$

The nozzle neck thickness is adequate.

Reinforcement check in the plane parallel to the longitudinal axis

Reinforcement Calculations for Internal Pressure

UG-37 Area Calculation Summary (cm ²)							UG-45 Summary (mm)	
For P = 21 bar @ 120 °C The opening is adequately reinforced							The nozzle passes UG-45	
A required	A available	A ₁	A ₂	A ₃	A ₅	A welds	t _{req}	t _{min}
14,1826	16,5097	11,1884	2,2226	2,0981	-	1,0006	6,92	7,16

UG-41 Weld Failure Path Analysis Summary
The nozzle is exempt from weld strength calculations per UW-15(b)(1)

UW-16 Weld Sizing Summary			
Weld description	Required weld throat size (mm)	Actual weld throat size (mm)	Status
Nozzle to shell fillet (Leg ₄₁)	5,73	6,3	weld size is adequate

Parallel Limit of reinforcement per UG-40

$$\begin{aligned}
 L_R &= \text{MAX}(d, R_n + (t_n - C_n) + (t - C)) \\
 &= \text{MAX}(202,72, 101,36 + (8,18 - 0) + (12,5 - 0)) \\
 &= 202,72 \text{ mm}
 \end{aligned}$$

Outer Normal Limit of reinforcement per UG-40

$$\begin{aligned}
 L_H &= \text{MIN}(2,5*(t - C), 2,5*(t_n - C_n) + t_e) \\
 &= \text{MIN}(2,5*(12,5 - 0), 2,5*(8,18 - 0) + 0) \\
 &= 20,45 \text{ mm}
 \end{aligned}$$

Inner Normal Limit of reinforcement per UG-40

$$\begin{aligned}
 L_i &= \text{MIN}(h, 2,5*(t - C), 2,5*(t_i - C_n - C)) \\
 &= \text{MIN}(15, 2,5*(12,5 - 0), 2,5*(8,18 - 0 - 0)) \\
 &= 15 \text{ mm}
 \end{aligned}$$

Nozzle required thickness per UG-27(c)(1)

$$\begin{aligned}
 t_{rn} &= P * R_n / (S_n * E - 0,6 * P) \\
 &= 21,0003 * 101,36 / (1,180 * 1 - 0,6 * 21,0003) \\
 &= 1,82 \text{ mm}
 \end{aligned}$$

Required thickness t_r from UG-37(a)

$$\begin{aligned}
 t_r &= P * R_o / (S * E + 0,4 * P) \\
 &= 21,0003 * 457,2 / (1,380 * 1 + 0,4 * 21,0003) \\
 &= 6,92 \text{ mm}
 \end{aligned}$$

Area required per UG-37(c)

Allowable stresses: S_n = 1.203,265, S_v = 1.407,208 kgf/cm²

$$f_{r1} = \text{lesser of } 1 \text{ or } S_n / S_v = 0,8551$$

$$f_{r2} = \text{lesser of } 1 \text{ or } S_n / S_v = 0,8551$$

$$\begin{aligned}
 A &= d \cdot t_r \cdot F + 2 \cdot t_n \cdot t_r \cdot F \cdot (1 - f_{r1}) \\
 &= (202,72 \cdot 6,92 \cdot 1 + 2 \cdot 8,18 \cdot 6,92 \cdot 1 \cdot (1 - 0,8551)) / 100 \\
 &= \underline{14,1826} \text{ cm}^2
 \end{aligned}$$

Area available from FIG. UG-37.1

$$A_1 = \text{larger of the following} = \underline{11,1884} \text{ cm}^2$$

$$\begin{aligned}
 &= d \cdot (E_1 \cdot t - F \cdot t_r) - 2 \cdot t_n \cdot (E_1 \cdot t - F \cdot t_r) \cdot (1 - f_{r1}) \\
 &= (202,72 \cdot (1 \cdot 12,5 - 1 \cdot 6,92) - 2 \cdot 8,18 \cdot (1 \cdot 12,5 - 1 \cdot 6,92) \cdot (1 - 0,8551)) / 100 \\
 &= 11,1884 \text{ cm}^2 \\
 &= 2 \cdot (t + t_n) \cdot (E_1 \cdot t - F \cdot t_r) - 2 \cdot t_n \cdot (E_1 \cdot t - F \cdot t_r) \cdot (1 - f_{r1}) \\
 &= (2 \cdot (12,5 + 8,18) \cdot (1 \cdot 12,5 - 1 \cdot 6,92) - 2 \cdot 8,18 \cdot (1 \cdot 12,5 - 1 \cdot 6,92) \cdot (1 - 0,8551)) / 100 \\
 &= 2,1774 \text{ cm}^2
 \end{aligned}$$

$$A_2 = \text{smaller of the following} = \underline{2,2226} \text{ cm}^2$$

$$\begin{aligned}
 &= 5 \cdot (t_n - t_{rn}) \cdot f_{r2} \cdot t \\
 &= (5 \cdot (8,18 - 1,82) \cdot 0,8551 \cdot 12,5) / 100 \\
 &= 3,3961 \text{ cm}^2 \\
 &= 5 \cdot (t_n - t_{rn}) \cdot f_{r2} \cdot t_n \\
 &= (5 \cdot (8,18 - 1,82) \cdot 0,8551 \cdot 8,18) / 100 \\
 &= 2,2226 \text{ cm}^2
 \end{aligned}$$

$$A_3 = \text{smaller of the following} = \underline{2,0981} \text{ cm}^2$$

$$\begin{aligned}
 &= 5 \cdot t_i \cdot f_{r2} \\
 &= (5 \cdot 12,5 \cdot 8,18 \cdot 0,8551) / 100 \\
 &= \underline{4,3711} \text{ cm}^2 \\
 &= 5 \cdot t_i \cdot f_{r2} \\
 &= (5 \cdot 8,18 \cdot 8,18 \cdot 0,8551) / 100 \\
 &= \underline{2,86} \text{ cm}^2 \\
 &= 2 \cdot h \cdot t_i \cdot f_{r2} \\
 &= (2 \cdot 15 \cdot 8,18 \cdot 0,8551) / 100 \\
 &= \underline{2,0981} \text{ cm}^2
 \end{aligned}$$

$$\begin{aligned}
 A_{41} &= \text{Leg}^2 \cdot f_{r2} \\
 &= (9^2 \cdot 0,8551) / 100 \\
 &= \underline{0,6929} \text{ cm}^2
 \end{aligned}$$

$$\begin{aligned}
 A_{43} &= \text{Leg}^2 \cdot f_{r2} \\
 &= (6^2 \cdot 0,8551) / 100 \\
 &= \underline{0,3077} \text{ cm}^2
 \end{aligned}$$

$$\begin{aligned}
 \text{Area} &= A_1 + A_2 + A_3 + A_{41} + A_{43} \\
 &= 11,1884 + 2,2226 + 2,0981 + 0,6929 + 0,3077 \\
 &= \underline{16,5097} \text{ cm}^2
 \end{aligned}$$

As Area \geq A the reinforcement is adequate.

UG-45 Nozzle Neck Thickness Check

$$\begin{aligned}
 t_{a \text{ UG-27}} &= P \cdot R_n / (S_n \cdot E - 0,6 \cdot P) + \text{Corrosion} \\
 &= 21,0003 \cdot 101,36 / (1,180 \cdot 1 - 0,6 \cdot 21,0003) + 0 \\
 &= 1,82 \text{ mm}
 \end{aligned}$$

$$\begin{aligned}
 t_a &= \max[t_{a \text{ UG-27}}, t_{a \text{ UG-22}}] \\
 &= \max[1,82, 0] \\
 &= 1,82 \text{ mm}
 \end{aligned}$$

$$\begin{aligned}
 t_{b1} &= P \cdot R_o / (S \cdot E + 0,4 \cdot P) + \text{Corrosion} \\
 &= 21,0003 \cdot 457,2 / (1,380 \cdot 1 + 0,4 \cdot 21,0003) + 0 \\
 &= 6,92 \text{ mm}
 \end{aligned}$$

$$\begin{aligned}
 t_{b1} &= \max[t_{b1}, t_{b \text{ UG16}}] \\
 &= \max[6,92, 1,5] \\
 &= 6,92 \text{ mm}
 \end{aligned}$$

$$\begin{aligned}
 t_b &= \min[t_{b3}, t_{b1}] \\
 &= \min[7,16, 6,92] \\
 &= 6,92 \text{ mm}
 \end{aligned}$$

$$\begin{aligned}
 t_{\text{UG-45}} &= \max[t_a, t_b] \\
 &= \max[1,82, 6,92] \\
 &= \underline{6,92} \text{ mm}
 \end{aligned}$$

Available nozzle wall thickness new, $t_n = 0,875 \cdot 8,18 = 7,16 \text{ mm}$

The nozzle neck thickness is adequate.

Separator Outlet (B)

ASME Section VIII Division 1, 2019 Edition Metric

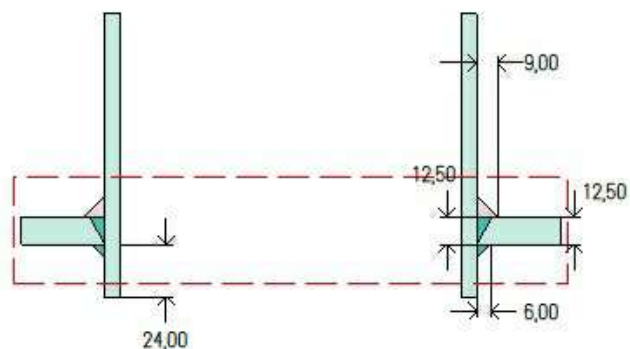

Note: round inside edges per UG-76(c)

Location and Orientation

Located on	Cylinder #1
Orientation	315°
Nozzle center line offset to datum line	304,8 mm
End of nozzle to shell center	778,2 mm
Passes through a Category A joint	No

Nozzle

Description	NPS 6 Sch 40 (Std) DN 150
Access opening	No
Material specification	SA-106 B Smls Pipe (II-D Metric p. 16, In. 10)
Inside diameter, new	154,05 mm
Pipe nominal wall thickness	7,11 mm
Pipe minimum wall thickness ¹	6,22 mm
Corrosion allowance	0 mm
Projection available outside vessel, L _{pr}	321 mm
Internal projection, h _{new}	24 mm
Local vessel minimum thickness	12,5 mm
Liquid static head included	0,01 bar
Longitudinal joint efficiency	1

Welds

Inner fillet, Leg ₄₁	9 mm
Lower fillet, Leg ₄₃	6 mm
Nozzle to vessel groove weld	12,5 mm

¹Pipe minimum thickness = nominal thickness times pipe tolerance factor of 0,875.

UCS-66 Material Toughness Requirements Nozzle	
$t_r = 21,01 \cdot 77,03 / (1.180 \cdot 1 - 0,6 \cdot 21,01) =$	1,39 mm
Stress ratio = $t_r \cdot E^* / (t_n - c) = 1,39 \cdot 1 / (6,22 - 0) =$	0,2228
Stress ratio $\leq 0,35$, MDMT per UCS-66(b)(3) =	-105°C
Material is exempt from impact testing at the Design MDMT of -29°C.	

Reinforcement Calculations for Internal Pressure

UG-37 Area Calculation Summary (cm ²)							UG-45 Summary (mm)	
For P = 21,01 bar @ 120 °C The opening is adequately reinforced							The nozzle passes UG-45	
A required	A available	A ₁	A ₂	A ₃	A ₅	A welds	t _{req}	t _{min}
10,8025	13,3851	8,4813	1,7406	2,1626	-	1,0006	6,22	6,22

UG-41 Weld Failure Path Analysis Summary
The nozzle is exempt from weld strength calculations per UW-15(b)(1)

UW-16 Weld Sizing Summary			
Weld description	Required weld throat size (mm)	Actual weld throat size (mm)	Status
Nozzle to shell fillet (Leg ₄₁)	4,98	6,3	weld size is adequate

Calculations for internal pressure 21,01 bar @ 120 °C

Parallel Limit of reinforcement per UG-40

$$\begin{aligned}
 L_R &= \text{MAX}(d, R_n + (t_n - C_n) + (t - C)) \\
 &= \text{MAX}(154,05, 77,03 + (7,11 - 0) + (12,5 - 0)) \\
 &= 154,05 \text{ mm}
 \end{aligned}$$

Outer Normal Limit of reinforcement per UG-40

$$\begin{aligned}
 L_H &= \text{MIN}(2,5*(t - C), 2,5*(t_n - C_n) + t_e) \\
 &= \text{MIN}(2,5*(12,5 - 0), 2,5*(7,11 - 0) + 0) \\
 &= 17,78 \text{ mm}
 \end{aligned}$$

Inner Normal Limit of reinforcement per UG-40

$$\begin{aligned}
 L_I &= \text{MIN}(h, 2,5*(t - C), 2,5*(t_i - C_n - C)) \\
 &= \text{MIN}(24, 2,5*(12,5 - 0), 2,5*(7,11 - 0 - 0)) \\
 &= 17,78 \text{ mm}
 \end{aligned}$$

Nozzle required thickness per UG-27(c)(1)

$$\begin{aligned}
 t_{rn} &= P * R_n / (S_n * E - 0,6 * P) \\
 &= 21,0131 * 77,03 / (1.180 * 1 - 0,6 * 21,0131) \\
 &= 1,39 \text{ mm}
 \end{aligned}$$

Required thickness t_r from UG-37(a)

$$\begin{aligned}
 t_r &= P * R_o / (S * E + 0,4 * P) \\
 &= 21,0131 * 457,2 / (1.380 * 1 + 0,4 * 21,0131) \\
 &= 6,92 \text{ mm}
 \end{aligned}$$

Area required per UG-37(c)

Allowable stresses: S_n = 1.203,265, S_v = 1.407,208 kgf/cm²

$$f_{r1} = \text{lesser of } 1 \text{ or } S_n / S_v = 0,8551$$

$$f_{r2} = \text{lesser of } 1 \text{ or } S_n / S_v = 0,8551$$

$$\begin{aligned}
 A &= d * t_r * F + 2 * t_n * t_r * F * (1 - f_{r1}) \\
 &= (154,05 * 6,92 * 1 + 2 * 7,11 * 6,92 * 1 * (1 - 0,8551)) / 100 \\
 &= [10,8025](#) \text{ cm}^2
 \end{aligned}$$

Area available from FIG. UG-37.1

$A_1 =$ larger of the following = 8,4813 cm^2

$$\begin{aligned} &= d(E_1 t - F t_r) - 2 t_n (E_1 t - F t_r) (1 - f_{r1}) \\ &= (154,05(1 \cdot 12,5 - 1 \cdot 6,92) - 2 \cdot 7,11(1 \cdot 12,5 - 1 \cdot 6,92)(1 - 0,8551)) / 100 \\ &= 8,4813 \text{ cm}^2 \\ &= 2(t + t_n)(E_1 t - F t_r) - 2 t_n (E_1 t - F t_r) (1 - f_{r1}) \\ &= (2(12,5 + 7,11)(1 \cdot 12,5 - 1 \cdot 6,92) - 2 \cdot 7,11(1 \cdot 12,5 - 1 \cdot 6,92)(1 - 0,8551)) / 100 \\ &= 2,0735 \text{ cm}^2 \end{aligned}$$

$A_2 =$ smaller of the following = 1,7406 cm^2

$$\begin{aligned} &= 5(t_n - t_{rn}) f_{r2} t \\ &= (5(7,11 - 1,39) \cdot 0,8551 \cdot 12,5) / 100 \\ &= 3,06 \text{ cm}^2 \\ &= 5(t_n - t_{rn}) f_{r2} t_n \\ &= (5(7,11 - 1,39) \cdot 0,8551 \cdot 7,11) / 100 \\ &= 1,7406 \text{ cm}^2 \end{aligned}$$

$A_3 =$ smaller of the following = 2,1626 cm^2

$$\begin{aligned} &= 5 t_i f_{r2} \\ &= (5 \cdot 12,5 \cdot 7,11 \cdot 0,8551) / 100 \\ &= 3,8009 \text{ cm}^2 \\ &= 5 t_i t_i f_{r2} \\ &= (5 \cdot 7,11 \cdot 7,11 \cdot 0,8551) / 100 \\ &= 2,1626 \text{ cm}^2 \\ &= 2 h t_i f_{r2} \\ &= (2 \cdot 24 \cdot 7,11 \cdot 0,8551) / 100 \\ &= 2,9191 \text{ cm}^2 \end{aligned}$$

$$\begin{aligned} A_{41} &= \text{Leg}^2 f_{r2} \\ &= (9^2 \cdot 0,8551) / 100 \\ &= 0,6929 \text{ cm}^2 \end{aligned}$$

$$\begin{aligned} A_{43} &= \text{Leg}^2 f_{r2} \\ &= (6^2 \cdot 0,8551) / 100 \\ &= 0,3077 \text{ cm}^2 \end{aligned}$$

$$\begin{aligned} \text{Area} &= A_1 + A_2 + A_3 + A_{41} + A_{43} \\ &= 8,4813 + 1,7406 + 2,1626 + 0,6929 + 0,3077 \\ &= 13,3851 \text{ cm}^2 \end{aligned}$$

As Area \geq A the reinforcement is adequate.

UW-16(c) Weld Check

Fillet weld: t_{\min} = lesser of 19 mm or t_n or $t = 7,11$ mm

$t_{c(\min)}$ = lesser of 6 mm or $0,7 \cdot t_{\min} = 4,98$ mm

$t_{c(\text{actual})} = 0,7 \cdot \text{Leg} = 0,7 \cdot 9 = 6,3$ mm

The fillet weld size is satisfactory.

Weld strength calculations are not required for this detail which conforms to Fig. UW-16.1, sketch (c-e).

UG-45 Nozzle Neck Thickness Check

$$\begin{aligned}
 t_{a \text{ UG-27}} &= P \cdot R_n / (S_n \cdot E - 0,6 \cdot P) + \text{Corrosion} \\
 &= 21,0131 \cdot 77,03 / (1,180 \cdot 1 - 0,6 \cdot 21,0131) + 0 \\
 &= 1,39 \text{ mm}
 \end{aligned}$$

$$\begin{aligned}
 t_a &= \max[t_{a \text{ UG-27}}, t_{a \text{ UG-22}}] \\
 &= \max[1,39, 0] \\
 &= 1,39 \text{ mm}
 \end{aligned}$$

$$\begin{aligned}
 t_{b1} &= P \cdot R_o / (S \cdot E + 0,4 \cdot P) + \text{Corrosion} \\
 &= 21,0131 \cdot 457,2 / (1,380 \cdot 1 + 0,4 \cdot 21,0131) + 0 \\
 &= 6,92 \text{ mm}
 \end{aligned}$$

$$\begin{aligned}
 t_{b1} &= \max[t_{b1}, t_{b \text{ UG16}}] \\
 &= \max[6,92, 1,5] \\
 &= 6,92 \text{ mm}
 \end{aligned}$$

$$\begin{aligned}
 t_b &= \min[t_{b3}, t_{b1}] \\
 &= \min[6,22, 6,92] \\
 &= 6,22 \text{ mm}
 \end{aligned}$$

$$\begin{aligned}
 t_{\text{UG-45}} &= \max[t_a, t_b] \\
 &= \max[1,39, 6,22] \\
 &= \underline{6,22} \text{ mm}
 \end{aligned}$$

Available nozzle wall thickness new, $t_n = 0,875 \cdot 7,11 = 6,22 \text{ mm}$

The nozzle neck thickness is adequate.

Liquid Injection (E)

ASME Section VIII Division 1, 2019 Edition Metric

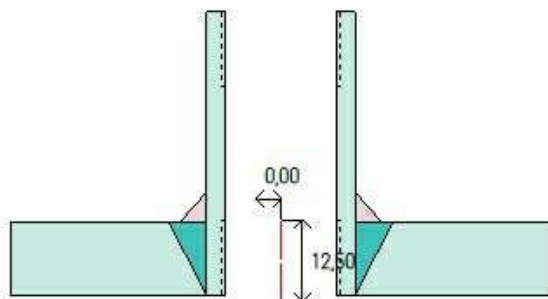

Note: round inside edges per UG-76(c)

Location and Orientation

Located on	Cylinder #1
Orientation	290°
Nozzle center line offset to datum line	863,6 mm
End of nozzle to shell center	492,22 mm
Passes through a Category A joint	No

Nozzle

Description	NPS 0,5 Class 3000 DN 15 - Threaded Full Coupling
Access opening	No
Material specification	SA-105 (II-D Metric p. 20, ln. 19)
Inside diameter, new	21,34 mm
Nominal wall thickness	3,56 mm
Corrosion allowance	0 mm
Projection available outside vessel, L_{pr}	35,02 mm
Local vessel minimum thickness	12,5 mm
Liquid static head included	0,03 bar
Longitudinal joint efficiency	1

Welds

Inner fillet, Leg₄₁	5 mm
Nozzle to vessel groove weld	12,5 mm

UCS-66 Material Toughness Requirements Nozzle

$t_r = 21,03 * 10,67 / (1,380 * 1 - 0,6 * 21,03) =$	0,16 mm
Stress ratio = $t_r * E^* / (t_n - c) = 0,16 * 1 / (3,56 - 0) =$	0,0461
Stress ratio $\leq 0,35$, MDMT per UCS-66(b)(3) =	-105°C
Material is exempt from impact testing at the Design MDMT of -29°C.	

Reinforcement Calculations for Internal Pressure

UG-37 Area Calculation Summary (cm ²)							UG-44 Summary (mm)	
For P = 21,03 bar @ 120 °C							The nozzle passes UG-44	
A required	A available	A ₁	A ₂	A ₃	A ₅	A welds	t _{req}	t _{min}
This nozzle is exempt from area calculations per UG-36(c)(3)(a)							1,5	3,56

UG-41 Weld Failure Path Analysis Summary
The nozzle is exempt from weld strength calculations per UW-15(b)(2)

UW-16 Weld Sizing Summary			
Weld description	Required weld throat size (mm)	Actual weld throat size (mm)	Status
Nozzle to shell fillet (Leg ₄₁)	2,49	3,5	weld size is adequate

Calculations for internal pressure 21,03 bar @ 120 °C

Parallel Limit of reinforcement per UG-40

$$\begin{aligned}
 L_R &= \text{MAX}(d, R_n + (t_n - C_n) + (t - C)) \\
 &= \text{MAX}(21,34, 10,67 + (3,56 - 0) + (12,5 - 0)) \\
 &= 26,72 \text{ mm}
 \end{aligned}$$

Outer Normal Limit of reinforcement per UG-40

$$\begin{aligned}
 L_H &= \text{MIN}(2,5*(t - C), 2,5*(t_n - C_n) + t_e) \\
 &= \text{MIN}(2,5*(12,5 - 0), 2,5*(3,56 - 0) + 0) \\
 &= 8,89 \text{ mm}
 \end{aligned}$$

Nozzle required thickness per UG-27(c)(1)

$$\begin{aligned}
 t_{rn} &= P * R_n / (S_n * E - 0,6 * P) \\
 &= 21,0295 * 10,67 / (1,380 * 1 - 0,6 * 21,0295) \\
 &= 0,17 \text{ mm}
 \end{aligned}$$

Required thickness t_r from UG-37(a)

$$\begin{aligned}
 t_r &= P * R_o / (S * E + 0,4 * P) \\
 &= 21,0295 * 457,2 / (1,380 * 1 + 0,4 * 21,0295) \\
 &= 6,93 \text{ mm}
 \end{aligned}$$

This opening does not require reinforcement per UG-36(c)(3)(a)

UW-16(c) Weld Check

Fillet weld: t_{min} = lesser of 19 mm or t_n or t = 3,56 mm

t_{c(min)} = lesser of 2,5 mm or 0,7*t_{min} = 2,49 mm

t_{c(actual)} = 0,7*Leg = 0,7*5 = 3,5 mm

The fillet weld size is satisfactory.

Weld strength calculations are not required for this detail which conforms to Fig. UW-16.1, sketch (c-e).

UG-44 Thickness Check - ASME B16.11 Coupling

$$\begin{aligned}
 t_{a \text{ App 1-1}} &= P * R_o / (S_n * E + 0,4 * P) + \text{Corrosion} \\
 &= 21,0295 * 14,22 / (1,380 * 1 + 0,4 * 21,0295) + 0 \\
 &= 0,22 \text{ mm}
 \end{aligned}$$

$$\begin{aligned} t_{a \text{ UG-44}} &= \max[t_{a \text{ App 1-1}}, t_{b \text{ UG16}}] \\ &= \max[0,22, 1,5] \\ &= 1,5 \text{ mm} \end{aligned}$$

Available nozzle wall thickness new, $t_n = 3,56$ mm

The nozzle neck thickness is adequate.

Oil Drain (F)

ASME Section VIII Division 1, 2019 Edition Metric

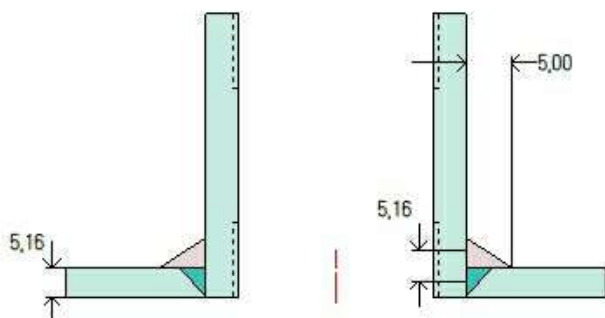

Note: round inside edges per UG-76(c)

Location and Orientation

Located on	Oil Outlet (T)
Orientation	270°
Nozzle center line offset to face of parent nozzle	218 mm
End of nozzle to shell center	76,22 mm
Passes through a Category A joint	No

Nozzle

Description	NPS 0,5 Class 3000 DN 15 - Threaded Full Coupling
Access opening	No
Material specification	SA-105 (II-D Metric p. 20, ln. 19)
Inside diameter, new	21,34 mm
Nominal wall thickness	3,56 mm
Corrosion allowance	0 mm
Projection available outside vessel, L _{pr}	39,71 mm
Local vessel minimum thickness	4,51 mm
Liquid static head included	0,1 bar
Longitudinal joint efficiency	1

Welds

Inner fillet, Leg ₄₁	5 mm
Nozzle to vessel groove weld	5,16 mm

UCS-66 Material Toughness Requirements Nozzle

$t_r = 21,1 \cdot 10,67 / (1,380 \cdot 1 - 0,6 \cdot 21,1) =$	0,16 mm
Stress ratio = $t_r \cdot E^* / (t_n - c) = 0,16 \cdot 1 / (3,56 - 0) =$	0,0463
Stress ratio $\leq 0,35$, MDMT per UCS-66(b)(3) =	-105°C
Material is exempt from impact testing at the Design MDMT of -29°C.	

Reinforcement Calculations for Internal Pressure

UG-37 Area Calculation Summary (cm ²)							UG-44 Summary (mm)	
For P = 21,1 bar @ 120 °C							The nozzle passes UG-44	
A required	A available	A ₁	A ₂	A ₃	A ₅	A welds	t _{req}	t _{min}
This nozzle is exempt from area calculations per UG-36(c)(3)(a)							1,5	3,56

UG-41 Weld Failure Path Analysis Summary
The nozzle is exempt from weld strength calculations per UW-15(b)(2)

UW-16 Weld Sizing Summary			
Weld description	Required weld throat size (mm)	Actual weld throat size (mm)	Status
Nozzle to shell fillet (Leg ₄₁)	2,49	3,5	weld size is adequate

Calculations for internal pressure 21,1 bar @ 120 °C

Parallel Limit of reinforcement per UG-40

$$\begin{aligned}
 L_R &= \text{MAX}(d, R_n + (t_n - C_n) + (t - C)) \\
 &= \text{MAX}(21,34, 10,67 + (3,56 - 0) + (4,51 - 0)) \\
 &= 21,34 \text{ mm}
 \end{aligned}$$

Outer Normal Limit of reinforcement per UG-40

$$\begin{aligned}
 L_H &= \text{MIN}(2,5*(t - C), 2,5*(t_n - C_n) + t_e) \\
 &= \text{MIN}(2,5*(4,51 - 0), 2,5*(3,56 - 0) + 0) \\
 &= 8,89 \text{ mm}
 \end{aligned}$$

Nozzle required thickness per UG-27(c)(1)

$$\begin{aligned}
 t_{rn} &= P * R_n / (S_n * E - 0,6 * P) \\
 &= 21,1005 * 10,67 / (1,380 * 1 - 0,6 * 21,1005) \\
 &= 0,17 \text{ mm}
 \end{aligned}$$

Required thickness t_r from UG-37(a)

$$\begin{aligned}
 t_r &= P * R / (S * E - 0,6 * P) \\
 &= 21,1005 * 31,36 / (1,180 * 1 - 0,6 * 21,1005) \\
 &= 0,57 \text{ mm}
 \end{aligned}$$

This opening does not require reinforcement per UG-36(c)(3)(a)

UW-16(c) Weld Check

Fillet weld: t_{min} = lesser of 19 mm or t_n or t = 3,56 mm

t_{c(min)} = lesser of 2,5 mm or 0,7*t_{min} = 2,49 mm

t_{c(actual)} = 0,7*Leg = 0,7*5 = 3,5 mm

The fillet weld size is satisfactory.

Weld strength calculations are not required for this detail which conforms to Fig. UW-16.1, sketch (c-e).

UG-44 Thickness Check - ASME B16.11 Coupling

$$\begin{aligned}
 t_{a \text{ App 1-1}} &= P * R_o / (S_n * E + 0,4 * P) + \text{Corrosion} \\
 &= 21,1005 * 14,22 / (1,380 * 1 + 0,4 * 21,1005) + 0 \\
 &= 0,22 \text{ mm}
 \end{aligned}$$

$$\begin{aligned} t_{a \text{ UG-44}} &= \max[t_{a \text{ App 1-1}}, t_{b \text{ UG16}}] \\ &= \max[0,22, 1,5] \\ &= 1,5 \text{ mm} \end{aligned}$$

Available nozzle wall thickness new, $t_n = 3,56$ mm

The nozzle neck thickness is adequate.

Temperature Element (G)

ASME Section VIII Division 1, 2019 Edition Metric

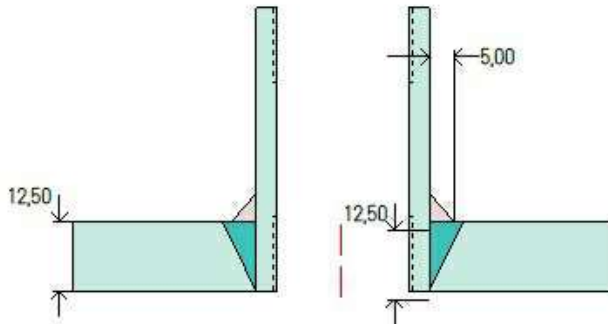

Note: round inside edges per UG-76(c)

Location and Orientation

Located on	Cylinder #1
Orientation	180°
Nozzle center line offset to datum line	2.387,6 mm
End of nozzle to shell center	495,15 mm
Passes through a Category A joint	No

Nozzle

Description	NPS 0,75 Class 3000 DN 20 - Threaded Full Coupling
Access opening	No
Material specification	SA-105 (II-D Metric p. 20, ln. 19)
Inside diameter, new	26,92 mm
Nominal wall thickness	4,06 mm
Corrosion allowance	0 mm
Projection available outside vessel, L _{pr}	37,95 mm
Local vessel minimum thickness	12,5 mm
Liquid static head included	0,09 bar
Longitudinal joint efficiency	1

Welds

Inner fillet, Leg ₄₁	5 mm
Nozzle to vessel groove weld	12,5 mm

UCS-66 Material Toughness Requirements Nozzle

$t_r = 21,09 \cdot 13,46 / (1,380 \cdot 1 - 0,6 \cdot 21,09) =$	0,21 mm
Stress ratio = $t_r \cdot E^* / (t_n - c) = 0,21 \cdot 1 / (4,06 - 0) =$	0,0511
Stress ratio $\leq 0,35$, MDMT per UCS-66(b)(3) =	-105°C
Material is exempt from impact testing at the Design MDMT of -29°C.	

Reinforcement Calculations for Internal Pressure

UG-37 Area Calculation Summary (cm ²)							UG-44 Summary (mm)	
For P = 21,09 bar @ 120 °C							The nozzle passes UG-44	
A required	A available	A ₁	A ₂	A ₃	A ₅	A welds	t _{req}	t _{min}
This nozzle is exempt from area calculations per UG-36(c)(3)(a)							1,5	4,06

UG-41 Weld Failure Path Analysis Summary
The nozzle is exempt from weld strength calculations per UW-15(b)(2)

UW-16 Weld Sizing Summary			
Weld description	Required weld throat size (mm)	Actual weld throat size (mm)	Status
Nozzle to shell fillet (Leg ₄₁)	2,5	3,5	weld size is adequate

Calculations for internal pressure 21,09 bar @ 120 °C

Parallel Limit of reinforcement per UG-40

$$\begin{aligned}
 L_R &= \text{MAX}(d, R_n + (t_n - C_n) + (t - C)) \\
 &= \text{MAX}(26,92, 13,46 + (4,06 - 0) + (12,5 - 0)) \\
 &= 30,03 \text{ mm}
 \end{aligned}$$

Outer Normal Limit of reinforcement per UG-40

$$\begin{aligned}
 L_H &= \text{MIN}(2,5*(t - C), 2,5*(t_n - C_n) + t_e) \\
 &= \text{MIN}(2,5*(12,5 - 0), 2,5*(4,06 - 0) + 0) \\
 &= 10,16 \text{ mm}
 \end{aligned}$$

Nozzle required thickness per UG-27(c)(1)

$$\begin{aligned}
 t_{rn} &= P * R_n / (S_n * E - 0,6 * P) \\
 &= 21,0896 * 13,46 / (1,380 * 1 - 0,6 * 21,0896) \\
 &= 0,21 \text{ mm}
 \end{aligned}$$

Required thickness t_r from UG-37(a)

$$\begin{aligned}
 t_r &= P * R_o / (S * E + 0,4 * P) \\
 &= 21,0896 * 457,2 / (1,380 * 1 + 0,4 * 21,0896) \\
 &= 6,94 \text{ mm}
 \end{aligned}$$

This opening does not require reinforcement per UG-36(c)(3)(a)

UW-16(c) Weld Check

Fillet weld: t_{min} = lesser of 19 mm or t_n or t = 4,06 mm

t_{c(min)} = lesser of 2,5 mm or 0,7*t_{min} = 2,5 mm

t_{c(actual)} = 0,7*Leg = 0,7*5 = 3,5 mm

The fillet weld size is satisfactory.

Weld strength calculations are not required for this detail which conforms to Fig. UW-16.1, sketch (c-e).

UG-44 Thickness Check - ASME B16.11 Coupling

$$\begin{aligned}
 t_{a \text{ App 1-1}} &= P * R_o / (S_n * E + 0,4 * P) + \text{Corrosion} \\
 &= 21,0933 * 17,53 / (1,380 * 1 + 0,4 * 21,0933) + 0 \\
 &= 0,27 \text{ mm}
 \end{aligned}$$

$$\begin{aligned} t_{a \text{ UG-44}} &= \max[t_{a \text{ App 1-1}}, t_{b \text{ UG16}}] \\ &= \max[0,27, 1,5] \\ &= 1,5 \text{ mm} \end{aligned}$$

Available nozzle wall thickness new, $t_n = 4,06$ mm

The nozzle neck thickness is adequate.

Temperature Element (J)

ASME Section VIII Division 1, 2019 Edition Metric

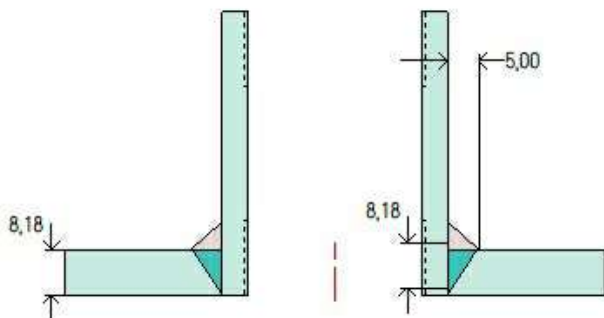

Note: round inside edges per UG-76(c)

Location and Orientation

Located on	Separator Inlet (A)
Orientation	270°
Nozzle center line offset to face of parent nozzle	140 mm
End of nozzle to shell center	150,75 mm
Passes through a Category A joint	No

Nozzle

Description	NPS 0,75 Class 3000 DN 20 - Threaded Full Coupling
Access opening	No
Material specification	SA-105 (II-D Metric p. 20, ln. 19)
Inside diameter, new	26,92 mm
Nominal wall thickness	4,06 mm
Corrosion allowance	0 mm
Projection available outside vessel, L _{pr}	41,21 mm
Local vessel minimum thickness	7,16 mm
Liquid static head included	0 bar
Longitudinal joint efficiency	1

Welds

Inner fillet, Leg ₄₁	5 mm
Nozzle to vessel groove weld	8,18 mm

UCS-66 Material Toughness Requirements Nozzle

$t_r = 21 \cdot 13,46 / (1,380 \cdot 1 - 0,6 \cdot 21) =$	0,21 mm
Stress ratio = $t_r \cdot E^* / (t_n - c) = 0,21 \cdot 1 / (4,06 - 0) =$	0,0509
Stress ratio $\leq 0,35$, MDMT per UCS-66(b)(3) =	-105°C
Material is exempt from impact testing at the Design MDMT of -29°C.	

Reinforcement Calculations for Internal Pressure

UG-37 Area Calculation Summary (cm ²)							UG-44 Summary (mm)	
For P = 21 bar @ 120 °C							The nozzle passes UG-44	
A required	A available	A ₁	A ₂	A ₃	A ₅	A welds	t _{req}	t _{min}
This nozzle is exempt from area calculations per UG-36(c)(3)(a)							1,5	4,06

UG-41 Weld Failure Path Analysis Summary
The nozzle is exempt from weld strength calculations per UW-15(b)(2)

UW-16 Weld Sizing Summary			
Weld description	Required weld throat size (mm)	Actual weld throat size (mm)	Status
Nozzle to shell fillet (Leg ₄₁)	2,5	3,5	weld size is adequate

Calculations for internal pressure 21 bar @ 120 °C

Parallel Limit of reinforcement per UG-40

$$\begin{aligned}
 L_R &= \text{MAX}(d, R_n + (t_n - C_n) + (t - C)) \\
 &= \text{MAX}(26,92, 13,46 + (4,06 - 0) + (7,16 - 0)) \\
 &= 26,92 \text{ mm}
 \end{aligned}$$

Outer Normal Limit of reinforcement per UG-40

$$\begin{aligned}
 L_H &= \text{MIN}(2,5*(t - C), 2,5*(t_n - C_n) + t_e) \\
 &= \text{MIN}(2,5*(7,16 - 0), 2,5*(4,06 - 0) + 0) \\
 &= 10,16 \text{ mm}
 \end{aligned}$$

Nozzle required thickness per UG-27(c)(1)

$$\begin{aligned}
 t_{rn} &= P*R_n / (S_n*E - 0,6*P) \\
 &= 21*13,46 / (1.380*1 - 0,6*21) \\
 &= 0,21 \text{ mm}
 \end{aligned}$$

Required thickness t_r from UG-37(a)

$$\begin{aligned}
 t_r &= P*R / (S*E - 0,6*P) \\
 &= 21*101,36 / (1.180*1 - 0,6*21) \\
 &= 1,82 \text{ mm}
 \end{aligned}$$

This opening does not require reinforcement per UG-36(c)(3)(a)

UW-16(c) Weld Check

Fillet weld: t_{min} = lesser of 19 mm or t_n or t = 4,06 mm

t_{c(min)} = lesser of 2,5 mm or 0,7*t_{min} = 2,5 mm

t_{c(actual)} = 0,7*Leg = 0,7*5 = 3,5 mm

The fillet weld size is satisfactory.

Weld strength calculations are not required for this detail which conforms to Fig. UW-16.1, sketch (c-e).

UG-44 Thickness Check - ASME B16.11 Coupling

$$\begin{aligned}
 t_{a \text{ App 1-1}} &= P*R_o / (S_n*E + 0,4*P) + \text{Corrosion} \\
 &= 21*17,53 / (1.380*1 + 0,4*21) + 0 \\
 &= 0,26 \text{ mm}
 \end{aligned}$$

$$\begin{aligned} t_{a \text{ UG-44}} &= \max[t_{a \text{ App 1-1}}, t_{b \text{ UG16}}] \\ &= \max[0,26, 1,5] \\ &= 1,5 \text{ mm} \end{aligned}$$

Available nozzle wall thickness new, $t_n = 4,06$ mm

The nozzle neck thickness is adequate.

Relief Valve (K)

ASME Section VIII Division 1, 2019 Edition Metric

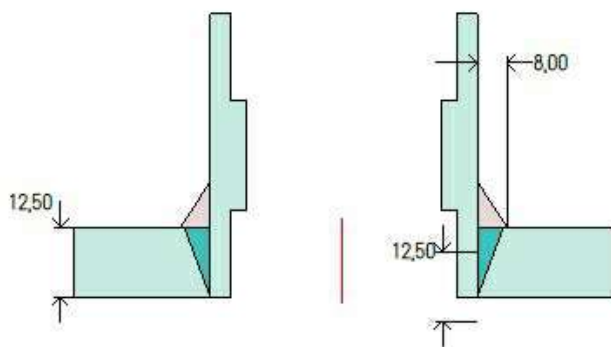

Note: round inside edges per UG-76(c)

Location and Orientation

Located on	Cylinder #1
Orientation	45°
Nozzle center line offset to datum line	203,2 mm
End of nozzle to shell center	493,72 mm
Passes through a Category A joint	No

Nozzle

Description	NPS 2 Class 3000 DN 50 - Socket-Welding Full Coupling
Access opening	No
Material specification	SA-105 (II-D Metric p. 20, ln. 19)
Socket bore diameter	61,62 mm
Bore diameter	53,26 mm
Socket depth	15,75 mm
Laying length	19,05 mm
Wall thickness	10,22 mm
Minimum wall thickness, t_n	6,05 mm
Corrosion allowance	0 mm
Projection available outside vessel, L_{pr}	36,52 mm
Local vessel minimum thickness	12,5 mm
Liquid static head included	0,01 bar
Longitudinal joint efficiency	1

Welds

Inner fillet, Leg_{41}	8 mm
Nozzle to vessel groove weld	12,5 mm

UCS-66 Material Toughness Requirements Nozzle	
$t_r = 21,01 \cdot 30,81 / (1,380 \cdot 1 - 0,6 \cdot 21,01) =$	0,47 mm
Stress ratio = $t_r \cdot E^* / (t_n - c) = 0,47 \cdot 1 / (6,05 - 0) =$	0,0783
Stress ratio $\leq 0,35$, MDMT per UCS-66(b)(3) =	-105°C
Material is exempt from impact testing at the Design MDMT of -29°C.	

Reinforcement Calculations for Internal Pressure

UG-37 Area Calculation Summary (cm ²)							UG-44 Summary (mm)	
For P = 21,01 bar @ 120 °C							The nozzle passes UG-44	
A required	A available	A ₁	A ₂	A ₃	A ₅	A welds	t _{req}	t _{min}
This nozzle is exempt from area calculations per UG-36(c)(3)(a)							1,5	6,05

UG-41 Weld Failure Path Analysis Summary
The nozzle is exempt from weld strength calculations per UW-15(b)(2)

UW-16 Weld Sizing Summary			
Weld description	Required weld throat size (mm)	Actual weld throat size (mm)	Status
Nozzle to shell fillet (Leg ₄₁)	2,5	5,6	weld size is adequate

Calculations for internal pressure 21,01 bar @ 120 °C

Parallel Limit of reinforcement per UG-40

$$\begin{aligned}
 L_R &= \text{MAX}(d, R_n + (t_n - C_n) + (t - C)) \\
 &= \text{MAX}(61,62, 30,81 + (6,05 - 0) + (12,5 - 0)) \\
 &= 61,62 \text{ mm}
 \end{aligned}$$

Outer Normal Limit of reinforcement per UG-40

$$\begin{aligned}
 L_H &= \text{MIN}(2,5*(t - C), 2,5*(t_n - C_n) + t_e) \\
 &= \text{MIN}(2,5*(12,5 - 0), 2,5*(6,05 - 0) + 0) \\
 &= 15,11 \text{ mm}
 \end{aligned}$$

Nozzle required thickness per UG-27(c)(1)

$$\begin{aligned}
 t_{rn} &= P * R_n / (S_n * E - 0,6 * P) \\
 &= 21,0131 * 30,81 / (1,380 * 1 - 0,6 * 21,0131) \\
 &= 0,47 \text{ mm}
 \end{aligned}$$

Required thickness t_r from UG-37(a)

$$\begin{aligned}
 t_r &= P * R_o / (S * E + 0,4 * P) \\
 &= 21,0131 * 457,2 / (1,380 * 1 + 0,4 * 21,0131) \\
 &= 6,92 \text{ mm}
 \end{aligned}$$

This opening does not require reinforcement per UG-36(c)(3)(a)

UW-16(c) Weld Check

Fillet weld: t_{min} = lesser of 19 mm or t_n or t = 10,22 mm

t_{c(min)} = lesser of 2,5 mm or 0,7*t_{min} = 2,5 mm

t_{c(actual)} = 0,7*Leg = 0,7*8 = 5,6 mm

The fillet weld size is satisfactory.

Weld strength calculations are not required for this detail which conforms to Fig. UW-16.1, sketch (c-e).

UG-44 Thickness Check - ASME B16.11 Coupling

$$\begin{aligned}
 t_{a \text{ App 1-1}} &= P * R_o / (S_n * E + 0,4 * P) + \text{Corrosion} \\
 &= 21,0131 * 36,86 / (1,380 * 1 + 0,4 * 21,0131) + 0 \\
 &= 0,56 \text{ mm}
 \end{aligned}$$

$$\begin{aligned} t_{a \text{ UG-44}} &= \max[t_{a \text{ App 1-1}}, t_{b \text{ UG16}}] \\ &= \max[0,56, 1,5] \\ &= 1,5 \text{ mm} \end{aligned}$$

Available nozzle wall thickness new, $t_n = 6,05$ mm

The nozzle neck thickness is adequate.

Pump out (L)

ASME Section VIII Division 1, 2019 Edition Metric

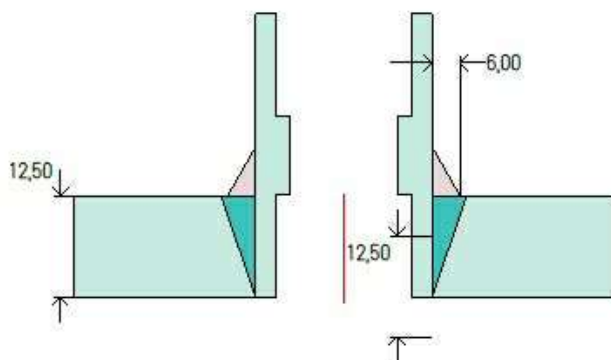

Note: round inside edges per UG-76(c)

Location and Orientation

Located on	Cylinder #1
Orientation	295°
Nozzle center line offset to datum line	177,8 mm
End of nozzle to shell center	479,39 mm
Passes through a Category A joint	No

Nozzle

Description	NPS 0,75 Class 3000 DN 20 - Socket-Welding Full Coupling
Access opening	No
Material specification	SA-105 (II-D Metric p. 20, ln. 19)
Socket bore diameter	27,56 mm
Bore diameter	21,69 mm
Socket depth	12,7 mm
Laying length	9,65 mm
Wall thickness	7,2 mm
Minimum wall thickness, t_n	4,27 mm
Corrosion allowance	0 mm
Projection available outside vessel, L_{pr}	22,19 mm
Local vessel minimum thickness	12,5 mm
Liquid static head included	0,03 bar
Longitudinal joint efficiency	1

Welds

Inner fillet, Leg_{41}	6 mm
Nozzle to vessel groove weld	12,5 mm

UCS-66 Material Toughness Requirements Nozzle	
$t_r = 21,03 \cdot 13,78 / (1,380 \cdot 1 - 0,6 \cdot 21,03) =$	0,21 mm
Stress ratio = $t_r \cdot E^* / (t_n - c) = 0,21 \cdot 1 / (4,27 - 0) =$	0,0497
Stress ratio $\leq 0,35$, MDMT per UCS-66(b)(3) =	-105°C
Material is exempt from impact testing at the Design MDMT of -29°C.	

Reinforcement Calculations for Internal Pressure

UG-37 Area Calculation Summary (cm ²)							UG-44 Summary (mm)	
For P = 21,03 bar @ 120 °C							The nozzle passes UG-44	
A required	A available	A ₁	A ₂	A ₃	A ₅	A welds	t _{req}	t _{min}
This nozzle is exempt from area calculations per UG-36(c)(3)(a)							1,5	4,27

UG-41 Weld Failure Path Analysis Summary
The nozzle is exempt from weld strength calculations per UW-15(b)(2)

UW-16 Weld Sizing Summary			
Weld description	Required weld throat size (mm)	Actual weld throat size (mm)	Status
Nozzle to shell fillet (Leg ₄₁)	2,5	4,2	weld size is adequate

Calculations for internal pressure 21,03 bar @ 120 °C

Parallel Limit of reinforcement per UG-40

$$\begin{aligned}
 L_R &= \text{MAX}(d, R_n + (t_n - C_n) + (t - C)) \\
 &= \text{MAX}(27,56, 13,78 + (4,27 - 0) + (12,5 - 0)) \\
 &= 30,55 \text{ mm}
 \end{aligned}$$

Outer Normal Limit of reinforcement per UG-40

$$\begin{aligned}
 L_H &= \text{MIN}(2,5*(t - C), 2,5*(t_n - C_n) + t_e) \\
 &= \text{MIN}(2,5*(12,5 - 0), 2,5*(4,27 - 0) + 0) \\
 &= 10,67 \text{ mm}
 \end{aligned}$$

Nozzle required thickness per UG-27(c)(1)

$$\begin{aligned}
 t_{rn} &= P * R_n / (S_n * E - 0,6 * P) \\
 &= 21,0259 * 13,78 / (1,380 * 1 - 0,6 * 21,0259) \\
 &= 0,21 \text{ mm}
 \end{aligned}$$

Required thickness t_r from UG-37(a)

$$\begin{aligned}
 t_r &= P * R_o / (S * E + 0,4 * P) \\
 &= 21,0259 * 457,2 / (1,380 * 1 + 0,4 * 21,0259) \\
 &= 6,92 \text{ mm}
 \end{aligned}$$

This opening does not require reinforcement per UG-36(c)(3)(a)

UW-16(c) Weld Check

Fillet weld: t_{min} = lesser of 19 mm or t_n or t = 7,2 mm

t_{c(min)} = lesser of 2,5 mm or 0,7*t_{min} = 2,5 mm

t_{c(actual)} = 0,7*Leg = 0,7*6 = 4,2 mm

The fillet weld size is satisfactory.

Weld strength calculations are not required for this detail which conforms to Fig. UW-16.1, sketch (c-e).

UG-44 Thickness Check - ASME B16.11 Coupling

$$\begin{aligned}
 t_{a \text{ App 1-1}} &= P * R_o / (S_n * E + 0,4 * P) + \text{Corrosion} \\
 &= 21,0259 * 18,05 / (1,380 * 1 + 0,4 * 21,0259) + 0 \\
 &= 0,27 \text{ mm}
 \end{aligned}$$

$$\begin{aligned} t_{a \text{ UG-44}} &= \max[t_{a \text{ App 1-1}}, t_{b \text{ UG16}}] \\ &= \max[0,27, 1,5] \\ &= 1,5 \text{ mm} \end{aligned}$$

Available nozzle wall thickness new, $t_n = 4,27$ mm

The nozzle neck thickness is adequate.

Oil Relief -Oil Pump (M)

ASME Section VIII Division 1, 2019 Edition Metric

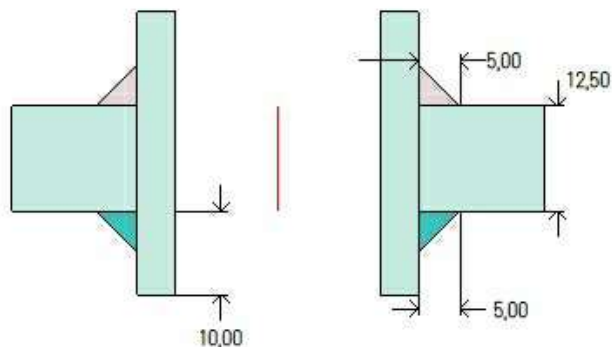

Note: round inside edges per UG-76(c)

Location and Orientation

Located on	Cylinder #1
Orientation	180°
Nozzle center line offset to datum line	3.022,6 mm
End of nozzle to shell center	516 mm
Offset from center, Lo	215,9 mm
Passes through a Category A joint	No

Nozzle

Description	NPS 1 Sch 80 (XS) DN 25
Access opening	No
Material specification	SA-106 B Smls Pipe (II-D Metric p. 16, In. 10)
Inside diameter, new	24,31 mm
Pipe nominal wall thickness	4,55 mm
Pipe minimum wall thickness ¹	3,98 mm
Corrosion allowance	0 mm
Opening chord length	27,74 mm
Projection available outside vessel, Lpr	104,48 mm
Internal projection, h _{new}	10 mm
Local vessel minimum thickness	12,5 mm
Liquid static head included	0,08 bar
Longitudinal joint efficiency	1

Welds

Inner fillet, Leg ₄₁	5 mm
Lower fillet, Leg ₄₃	5 mm

¹Pipe minimum thickness = nominal thickness times pipe tolerance factor of 0,875.

UCS-66 Material Toughness Requirements Nozzle	
---	--

Impact test exempt per UCS-66(d) (NPS 4 or smaller pipe) =	-105°C
--	--------

Material is exempt from impact testing at the Design MDMT of -29°C.	
---	--

Reinforcement Calculations for Internal Pressure

UG-37 Area Calculation Summary (cm ²)							UG-45 Summary (mm)	
For P = 21,08 bar @ 120 °C							The nozzle passes UG-45	
A required	A available	A ₁	A ₂	A ₃	A ₅	A welds	t _{req}	t _{min}
This nozzle is exempt from area calculations per UG-36(c)(3)(a)							2,96	3,98

UG-41 Weld Failure Path Analysis Summary
The nozzle is exempt from weld strength calculations per UW-15(b)(2)

UW-16 Weld Sizing Summary			
Weld description	Required weld throat size (mm)	Actual weld throat size (mm)	Status
Nozzle to shell fillet (Leg ₄₁)	3,18	3,5	weld size is adequate
Nozzle to inside shell fillet (Leg ₄₃)	3,18	3,5	weld size is adequate
Combined weld check (t ₁ + t ₂)	5,68	7	weld size is adequate

Calculations for internal pressure 21,08 bar @ 120 °C

Parallel Limit of reinforcement per UG-40

$$\begin{aligned}
 L_R &= \text{MAX}(d, R_n + (t_n - C_n) + (t - C)) \\
 &= \text{MAX}(27,74, 13,87 + (4,55 - 0) + (12,5 - 0)) \\
 &= 30,92 \text{ mm}
 \end{aligned}$$

Outer Normal Limit of reinforcement per UG-40

$$\begin{aligned}
 L_H &= \text{MIN}(2,5*(t - C), 2,5*(t_n - C_n) + t_e) \\
 &= \text{MIN}(2,5*(12,5 - 0), 2,5*(4,55 - 0) + 0) \\
 &= 11,37 \text{ mm}
 \end{aligned}$$

Inner Normal Limit of reinforcement per UG-40

$$\begin{aligned}
 L_I &= \text{MIN}(h, 2,5*(t - C), 2,5*(t_i - C_n - C)) \\
 &= \text{MIN}(10, 2,5*(12,5 - 0), 2,5*(4,55 - 0 - 0)) \\
 &= 10 \text{ mm}
 \end{aligned}$$

Nozzle required thickness per UG-27(c)(1)

$$\begin{aligned}
 t_{rn} &= P * R_n / (S_n * E - 0,6 * P) \\
 &= 21,0843 * 12,15 / (1.180 * 1 - 0,6 * 21,0843) \\
 &= 0,22 \text{ mm}
 \end{aligned}$$

Required thickness t_r from UG-37(a)

$$\begin{aligned}
 t_r &= P * R_o / (S * E + 0,4 * P) \\
 &= 21,0843 * 457,2 / (1.380 * 1 + 0,4 * 21,0843) \\
 &= 6,94 \text{ mm}
 \end{aligned}$$

This opening does not require reinforcement per UG-36(c)(3)(a)

UW-16(d) Weld Check

$t_{\min} = \text{lesser of } 19 \text{ mm or } t_n \text{ or } t = 4,55 \text{ mm}$

$t_{1(\min)} \text{ or } t_{2(\min)} = \text{lesser of } 6 \text{ mm or } 0,7*t_{\min} = 3,18 \text{ mm}$

$t_{1(\text{actual})} = 0,7*\text{Leg} = 0,7*5 = 3,5 \text{ mm}$

The weld size t_1 is satisfactory.

$t_{2(\text{actual})} = 0,7*\text{Leg} = 0,7*5 = 3,5 \text{ mm}$

The weld size t_2 is satisfactory.

$t_1 + t_2 = 7 \geq 1,25*t_{\min} = 5,68$

The combined weld sizes for t_1 and t_2 are satisfactory.

UG-45 Nozzle Neck Thickness Check

$$\begin{aligned} t_{a \text{ UG-27}} &= P*R_n / (S_n*E - 0,6*P) + \text{Corrosion} \\ &= 21,0954*12,15 / (1,180*1 - 0,6*21,0954) + 0 \\ &= 0,22 \text{ mm} \end{aligned}$$

$$\begin{aligned} t_a &= \max[t_{a \text{ UG-27}} , t_{a \text{ UG-22}}] \\ &= \max[0,22 , 0] \\ &= 0,22 \text{ mm} \end{aligned}$$

$$\begin{aligned} t_{b1} &= P*R_o / (S*E + 0,4*P) + \text{Corrosion} \\ &= 21,0843*457,2 / (1,380*1 + 0,4*21,0843) + 0 \\ &= 6,94 \text{ mm} \end{aligned}$$

$$\begin{aligned} t_{b1} &= \max[t_{b1} , t_{b \text{ UG16}}] \\ &= \max[6,94 , 1,5] \\ &= 6,94 \text{ mm} \end{aligned}$$

$$\begin{aligned} t_b &= \min[t_{b3} , t_{b1}] \\ &= \min[2,96 , 6,94] \\ &= 2,96 \text{ mm} \end{aligned}$$

$$\begin{aligned} t_{\text{UG-45}} &= \max[t_a , t_b] \\ &= \max[0,22 , 2,96] \\ &= 2,96 \text{ mm} \end{aligned}$$

Available nozzle wall thickness new, $t_n = 0,875*4,55 = 3,98 \text{ mm}$

The nozzle neck thickness is adequate.

Oil Drain (P)

ASME Section VIII Division 1, 2019 Edition Metric

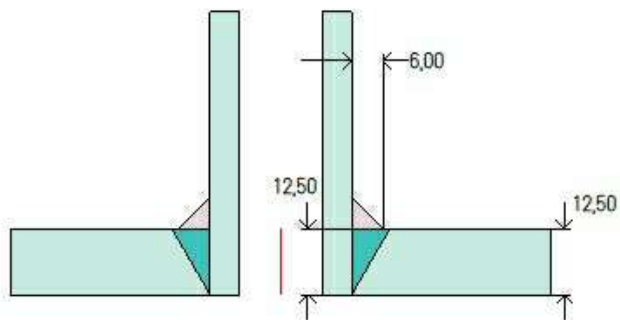

Note: round inside edges per UG-76(c)

Location and Orientation

Located on	Cylinder #1
Orientation	180°
Nozzle center line offset to datum line	1.054,1 mm
End of nozzle to shell center	546 mm
Passes through a Category A joint	No

Nozzle

Description	NPS 0,75 Sch 160 DN 20
Access opening	No
Material specification	SA-106 B Smls Pipe (II-D Metric p. 16, ln. 10)
Inside diameter, new	15,54 mm
Pipe nominal wall thickness	5,56 mm
Pipe minimum wall thickness¹	4,87 mm
Corrosion allowance	0 mm
Projection available outside vessel, L_{pr}	88,8 mm
Local vessel minimum thickness	12,5 mm
Liquid static head included	0,09 bar
Longitudinal joint efficiency	1

Welds

Inner fillet, Leg₄₁	6 mm
Nozzle to vessel groove weld	12,5 mm

¹Pipe minimum thickness = nominal thickness times pipe tolerance factor of 0,875.

UCS-66 Material Toughness Requirements Nozzle

Impact test exempt per UCS-66(d) (NPS 4 or smaller pipe) =	-105°C
Material is exempt from impact testing at the Design MDMT of -29°C.	

Reinforcement Calculations for Internal Pressure

UG-37 Area Calculation Summary (cm ²)							UG-45 Summary (mm)	
For P = 21,09 bar @ 120 °C							The nozzle passes UG-45	
A required	A available	A ₁	A ₂	A ₃	A ₅	A welds	t _{req}	t _{min}
This nozzle is exempt from area calculations per UG-36(c)(3)(a)							2,51	4,87

UG-41 Weld Failure Path Analysis Summary
The nozzle is exempt from weld strength calculations per UW-15(b)(2)

UW-16 Weld Sizing Summary			
Weld description	Required weld throat size (mm)	Actual weld throat size (mm)	Status
Nozzle to shell fillet (Leg ₄₁)	3,89	4,2	weld size is adequate

Calculations for internal pressure 21,09 bar @ 120 °C

Parallel Limit of reinforcement per UG-40

$$\begin{aligned}
 L_R &= \text{MAX}(d, R_n + (t_n - C_n) + (t - C)) \\
 &= \text{MAX}(15,54, 7,77 + (5,56 - 0) + (12,5 - 0)) \\
 &= 25,84 \text{ mm}
 \end{aligned}$$

Outer Normal Limit of reinforcement per UG-40

$$\begin{aligned}
 L_H &= \text{MIN}(2,5*(t - C), 2,5*(t_n - C_n) + t_e) \\
 &= \text{MIN}(2,5*(12,5 - 0), 2,5*(5,56 - 0) + 0) \\
 &= 13,91 \text{ mm}
 \end{aligned}$$

Nozzle required thickness per UG-27(c)(1)

$$\begin{aligned}
 t_{rn} &= P * R_n / (S_n * E - 0,6 * P) \\
 &= 21,0896 * 7,77 / (1,180 * 1 - 0,6 * 21,0896) \\
 &= 0,14 \text{ mm}
 \end{aligned}$$

Required thickness t_r from UG-37(a)

$$\begin{aligned}
 t_r &= P * R_o / (S * E + 0,4 * P) \\
 &= 21,0896 * 457,2 / (1,380 * 1 + 0,4 * 21,0896) \\
 &= 6,94 \text{ mm}
 \end{aligned}$$

This opening does not require reinforcement per UG-36(c)(3)(a)

UW-16(c) Weld Check

Fillet weld: t_{min} = lesser of 19 mm or t_n or t = 5,56 mm

t_{c(min)} = lesser of 6 mm or 0,7*t_{min} = 3,89 mm

t_{c(actual)} = 0,7*Leg = 0,7*6 = 4,2 mm

The fillet weld size is satisfactory.

Weld strength calculations are not required for this detail which conforms to Fig. UW-16.1, sketch (c-e).

UG-45 Nozzle Neck Thickness Check

$$\begin{aligned}
 t_{a \text{ UG-27}} &= P * R_n / (S_n * E - 0,6 * P) + \text{Corrosion} \\
 &= 21,0983 * 7,77 / (1,180 * 1 - 0,6 * 21,0983) + 0 \\
 &= 0,14 \text{ mm}
 \end{aligned}$$

$$\begin{aligned}
 t_a &= \max[t_{a \text{ UG-27}} , t_{a \text{ UG-22}}] \\
 &= \max[0,14 , 0] \\
 &= 0,14 \text{ mm}
 \end{aligned}$$

$$\begin{aligned}
 t_{b1} &= P \cdot R_o / (S \cdot E + 0,4 \cdot P) + \text{Corrosion} \\
 &= 21,0896 \cdot 457,2 / (1,380 \cdot 1 + 0,4 \cdot 21,0896) + 0 \\
 &= 6,94 \text{ mm}
 \end{aligned}$$

$$\begin{aligned}
 t_{b1} &= \max[t_{b1} , t_{b \text{ UG16}}] \\
 &= \max[6,94 , 1,5] \\
 &= 6,94 \text{ mm}
 \end{aligned}$$

$$\begin{aligned}
 t_b &= \min[t_{b3} , t_{b1}] \\
 &= \min[2,51 , 6,94] \\
 &= 2,51 \text{ mm}
 \end{aligned}$$

$$\begin{aligned}
 t_{\text{UG-45}} &= \max[t_a , t_b] \\
 &= \max[0,14 , 2,51] \\
 &= \underline{2,51} \text{ mm}
 \end{aligned}$$

Available nozzle wall thickness new, $t_n = 0,875 \cdot 5,56 = 4,87 \text{ mm}$

The nozzle neck thickness is adequate.

Heater Carrier (R)

ASME Section VIII Division 1, 2019 Edition Metric

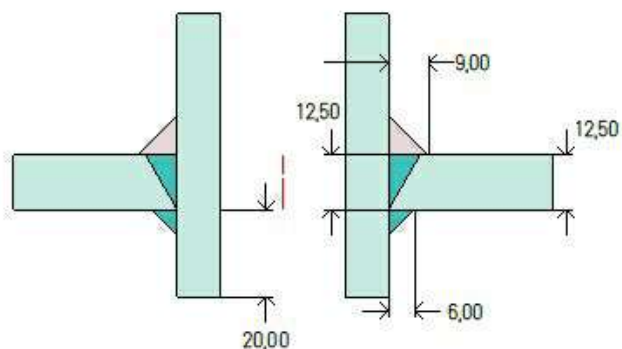

Note: round inside edges per UG-76(c)

Location and Orientation

Located on	Cylinder #1
Orientation	270°
Nozzle center line offset to datum line	1.600,2 mm
End of nozzle to shell center	457 mm
Offset from center, Lo	-330,2 mm
Passes through a Category A joint	No

Nozzle

Description	NPS 1,5 XXS DN 40
Access opening	No
Material specification	SA-106 B Smls Pipe (II-D Metric p. 16, In. 10)
Inside diameter, new	27,94 mm
Pipe nominal wall thickness	10,16 mm
Pipe minimum wall thickness ¹	8,89 mm
Corrosion allowance	0 mm
Opening chord length	41,37 mm
Projection available outside vessel, Lpr	117,36 mm
Internal projection, h _{new}	20 mm
Local vessel minimum thickness	12,5 mm
Liquid static head included	0,08 bar
Longitudinal joint efficiency	1

Welds

Inner fillet, Leg ₄₁	9 mm
Lower fillet, Leg ₄₃	6 mm
Nozzle to vessel groove weld	12,5 mm

¹Pipe minimum thickness = nominal thickness times pipe tolerance factor of 0,875.

UCS-66 Material Toughness Requirements Nozzle	
$t_r = 21,08 \cdot 13,97 / (1.180 \cdot 1 - 0,6 \cdot 21,08) =$	0,25 mm
Stress ratio = $t_r \cdot E^* / (t_n - c) = 0,25 \cdot 1 / (8,89 - 0) =$	0,0284
Stress ratio $\leq 0,35$, MDMT per UCS-66(b)(3) =	-105°C
Material is exempt from impact testing at the Design MDMT of -29°C.	

Reinforcement Calculations for Internal Pressure

UG-37 Area Calculation Summary (cm ²)							UG-45 Summary (mm)	
For P = 21,08 bar @ 120 °C							The nozzle passes UG-45	
A required	A available	A ₁	A ₂	A ₃	A ₅	A welds	t _{req}	t _{min}
This nozzle is exempt from area calculations per UG-36(c)(3)(a)							3,22	8,89

UG-41 Weld Failure Path Analysis Summary
The nozzle is exempt from weld strength calculations per UW-15(b)(2)

UW-16 Weld Sizing Summary			
Weld description	Required weld throat size (mm)	Actual weld throat size (mm)	Status
Nozzle to shell fillet (Leg ₄₁)	6	6,3	weld size is adequate

Calculations for internal pressure 21,08 bar @ 120 °C

Parallel Limit of reinforcement per UG-40

$$\begin{aligned}
 L_R &= \text{MAX}(d, R_n + (t_n - C_n) + (t - C)) \\
 &= \text{MAX}(41,37, 20,69 + (10,16 - 0) + (12,5 - 0)) \\
 &= 43,35 \text{ mm}
 \end{aligned}$$

Outer Normal Limit of reinforcement per UG-40

$$\begin{aligned}
 L_H &= \text{MIN}(2,5*(t - C), 2,5*(t_n - C_n) + t_e) \\
 &= \text{MIN}(2,5*(12,5 - 0), 2,5*(10,16 - 0) + 0) \\
 &= 25,4 \text{ mm}
 \end{aligned}$$

Inner Normal Limit of reinforcement per UG-40

$$\begin{aligned}
 L_I &= \text{MIN}(h, 2,5*(t - C), 2,5*(t_i - C_n - C)) \\
 &= \text{MIN}(20, 2,5*(12,5 - 0), 2,5*(10,16 - 0 - 0)) \\
 &= 20 \text{ mm}
 \end{aligned}$$

Nozzle required thickness per UG-27(c)(1)

$$\begin{aligned}
 t_{rn} &= P * R_n / (S_n * E - 0,6 * P) \\
 &= 21,0772 * 13,97 / (1,180 * 1 - 0,6 * 21,0772) \\
 &= 0,25 \text{ mm}
 \end{aligned}$$

Required thickness t_r from UG-37(a)

$$\begin{aligned}
 t_r &= P * R_o / (S * E + 0,4 * P) \\
 &= 21,0772 * 457,2 / (1,380 * 1 + 0,4 * 21,0772) \\
 &= 6,94 \text{ mm}
 \end{aligned}$$

This opening does not require reinforcement per UG-36(c)(3)(a)

UW-16(c) Weld Check

Fillet weld: t_{min} = lesser of 19 mm or t_n or t = 10,16 mm

t_{c(min)} = lesser of 6 mm or 0,7*t_{min} = 6 mm

t_{c(actual)} = 0,7*Leg = 0,7*9 = 6,3 mm

The fillet weld size is satisfactory.

Weld strength calculations are not required for this detail which conforms to Fig. UW-16.1, sketch (c-e).

UG-45 Nozzle Neck Thickness Check

$$\begin{aligned}t_{a \text{ UG-27}} &= P \cdot R_n / (S_n \cdot E - 0,6 \cdot P) + \text{Corrosion} \\ &= 21,0772 \cdot 13,97 / (1,180 \cdot 1 - 0,6 \cdot 21,0772) + 0 \\ &= 0,25 \text{ mm}\end{aligned}$$

$$\begin{aligned}t_a &= \max[t_{a \text{ UG-27}}, t_{a \text{ UG-22}}] \\ &= \max[0,25, 0] \\ &= 0,25 \text{ mm}\end{aligned}$$

$$\begin{aligned}t_{b1} &= P \cdot R_o / (S \cdot E + 0,4 \cdot P) + \text{Corrosion} \\ &= 21,0772 \cdot 457,2 / (1,380 \cdot 1 + 0,4 \cdot 21,0772) + 0 \\ &= 6,94 \text{ mm}\end{aligned}$$

$$\begin{aligned}t_{b1} &= \max[t_{b1}, t_{b \text{ UG16}}] \\ &= \max[6,94, 1,5] \\ &= 6,94 \text{ mm}\end{aligned}$$

$$\begin{aligned}t_b &= \min[t_{b3}, t_{b1}] \\ &= \min[3,22, 6,94] \\ &= 3,22 \text{ mm}\end{aligned}$$

$$\begin{aligned}t_{\text{UG-45}} &= \max[t_a, t_b] \\ &= \max[0,25, 3,22] \\ &= \underline{3,22} \text{ mm}\end{aligned}$$

Available nozzle wall thickness new, $t_n = 0,875 \cdot 10,16 = 8,89 \text{ mm}$

The nozzle neck thickness is adequate.

Reinforcement check in the plane parallel to the longitudinal axis

Reinforcement Calculations for Internal Pressure

UG-37 Area Calculation Summary (cm ²)							UG-45 Summary (mm)	
For P = 21,08 bar @ 120 °C							The nozzle passes UG-45	
A required	A available	A ₁	A ₂	A ₃	A ₅	A welds	t _{req}	t _{min}
This nozzle is exempt from area calculations per UG-36(c)(3)(a)							3,22	8,89

UG-41 Weld Failure Path Analysis Summary
The nozzle is exempt from weld strength calculations per UW-15(b)(2)

UW-16 Weld Sizing Summary			
Weld description	Required weld throat size (mm)	Actual weld throat size (mm)	Status
Nozzle to shell fillet (Leg ₄₁)	6	6,3	weld size is adequate

Parallel Limit of reinforcement per UG-40

$$\begin{aligned}
 L_R &= \text{MAX}(d, R_n + (t_n - C_n) + (t - C)) \\
 &= \text{MAX}(27,94, 13,97 + (10,16 - 0) + (12,5 - 0)) \\
 &= 36,63 \text{ mm}
 \end{aligned}$$

Outer Normal Limit of reinforcement per UG-40

$$\begin{aligned}
 L_H &= \text{MIN}(2,5*(t - C), 2,5*(t_n - C_n) + t_e) \\
 &= \text{MIN}(2,5*(12,5 - 0), 2,5*(10,16 - 0) + 0) \\
 &= 25,4 \text{ mm}
 \end{aligned}$$

Inner Normal Limit of reinforcement per UG-40

$$\begin{aligned}
 L_I &= \text{MIN}(h, 2,5*(t - C), 2,5*(t_i - C_n - C)) \\
 &= \text{MIN}(20, 2,5*(12,5 - 0), 2,5*(10,16 - 0 - 0)) \\
 &= 20 \text{ mm}
 \end{aligned}$$

Nozzle required thickness per UG-27(c)(1)

$$\begin{aligned}
 t_{rn} &= P * R_n / (S_n * E - 0,6 * P) \\
 &= 21,0772 * 13,97 / (1.180 * 1 - 0,6 * 21,0772) \\
 &= 0,25 \text{ mm}
 \end{aligned}$$

Required thickness t_r from UG-37(a)

$$\begin{aligned}
 t_r &= P * R_o / (S * E + 0,4 * P) \\
 &= 21,0772 * 457,2 / (1.380 * 1 + 0,4 * 21,0772) \\
 &= 6,94 \text{ mm}
 \end{aligned}$$

This opening does not require reinforcement per UG-36(c)(3)(a)

UG-45 Nozzle Neck Thickness Check

$$\begin{aligned}
 t_{a \text{ UG-27}} &= P * R_n / (S_n * E - 0,6 * P) + \text{Corrosion} \\
 &= 21,0772 * 13,97 / (1.180 * 1 - 0,6 * 21,0772) + 0 \\
 &= 0,25 \text{ mm}
 \end{aligned}$$

$$\begin{aligned}
 t_a &= \text{max}[t_{a \text{ UG-27}}, t_{a \text{ UG-22}}] \\
 &= \text{max}[0,25, 0] \\
 &= 0,25 \text{ mm}
 \end{aligned}$$

$$\begin{aligned}
 t_{b1} &= P \cdot R_o / (S \cdot E + 0,4 \cdot P) + \text{Corrosion} \\
 &= 21,0772 \cdot 457,2 / (1.380 \cdot 1 + 0,4 \cdot 21,0772) + 0 \\
 &= 6,94 \text{ mm}
 \end{aligned}$$

$$\begin{aligned}
 t_{b1} &= \max[t_{b1} , t_{b \text{UG16}}] \\
 &= \max[6,94 , 1,5] \\
 &= 6,94 \text{ mm}
 \end{aligned}$$

$$\begin{aligned}
 t_b &= \min[t_{b3} , t_{b1}] \\
 &= \min[3,22 , 6,94] \\
 &= 3,22 \text{ mm}
 \end{aligned}$$

$$\begin{aligned}
 t_{\text{UG-45}} &= \max[t_a , t_b] \\
 &= \max[0,25 , 3,22] \\
 &= \underline{3,22} \text{ mm}
 \end{aligned}$$

Available nozzle wall thickness new, $t_n = 0,875 \cdot 10,16 = 8,89 \text{ mm}$

The nozzle neck thickness is adequate.

Heater Carrier (R)

ASME Section VIII Division 1, 2019 Edition Metric

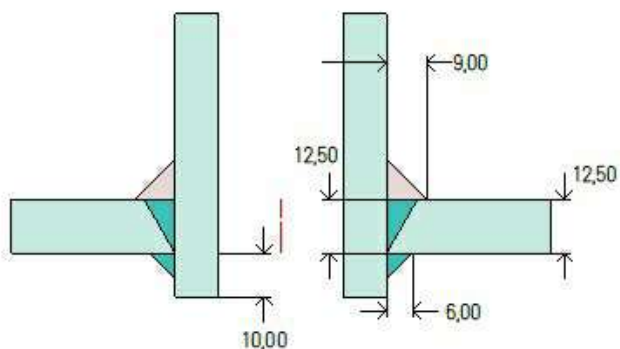

Note: round inside edges per UG-76(c)

Location and Orientation

Located on	Cylinder #1
Orientation	270°
Nozzle center line offset to datum line	2.921 mm
End of nozzle to shell center	457 mm
Offset from center, Lo	-330,2 mm
Passes through a Category A joint	No

Nozzle

Description	NPS 1,5 XXS DN 40
Access opening	No
Material specification	SA-106 B Smls Pipe (II-D Metric p. 16, In. 10)
Inside diameter, new	27,94 mm
Pipe nominal wall thickness	10,16 mm
Pipe minimum wall thickness ¹	8,89 mm
Corrosion allowance	0 mm
Opening chord length	41,37 mm
Projection available outside vessel, Lpr	117,36 mm
Internal projection, h _{new}	10 mm
Local vessel minimum thickness	12,5 mm
Liquid static head included	0,08 bar
Longitudinal joint efficiency	1

Welds

Inner fillet, Leg ₄₁	9 mm
Lower fillet, Leg ₄₃	6 mm
Nozzle to vessel groove weld	12,5 mm

¹Pipe minimum thickness = nominal thickness times pipe tolerance factor of 0,875.

UCS-66 Material Toughness Requirements Nozzle	
$t_r = 21,08 \cdot 13,97 / (1.180 \cdot 1 - 0,6 \cdot 21,08) =$	0,25 mm
Stress ratio = $t_r \cdot E^* / (t_n - c) = 0,25 \cdot 1 / (8,89 - 0) =$	0,0284
Stress ratio $\leq 0,35$, MDMT per UCS-66(b)(3) =	-105°C
Material is exempt from impact testing at the Design MDMT of -29°C.	

Reinforcement Calculations for Internal Pressure

UG-37 Area Calculation Summary (cm ²)							UG-45 Summary (mm)	
For P = 21,08 bar @ 120 °C							The nozzle passes UG-45	
A required	A available	A ₁	A ₂	A ₃	A ₅	A welds	t _{req}	t _{min}
This nozzle is exempt from area calculations per UG-36(c)(3)(a)							3,22	8,89

UG-41 Weld Failure Path Analysis Summary
The nozzle is exempt from weld strength calculations per UW-15(b)(2)

UW-16 Weld Sizing Summary			
Weld description	Required weld throat size (mm)	Actual weld throat size (mm)	Status
Nozzle to shell fillet (Leg ₄₁)	6	6,3	weld size is adequate

Calculations for internal pressure 21,08 bar @ 120 °C

Parallel Limit of reinforcement per UG-40

$$\begin{aligned}
 L_R &= \text{MAX}(d, R_n + (t_n - C_n) + (t - C)) \\
 &= \text{MAX}(41,37, 20,69 + (10,16 - 0) + (12,5 - 0)) \\
 &= 43,35 \text{ mm}
 \end{aligned}$$

Outer Normal Limit of reinforcement per UG-40

$$\begin{aligned}
 L_H &= \text{MIN}(2,5*(t - C), 2,5*(t_n - C_n) + t_e) \\
 &= \text{MIN}(2,5*(12,5 - 0), 2,5*(10,16 - 0) + 0) \\
 &= 25,4 \text{ mm}
 \end{aligned}$$

Inner Normal Limit of reinforcement per UG-40

$$\begin{aligned}
 L_I &= \text{MIN}(h, 2,5*(t - C), 2,5*(t_i - C_n - C)) \\
 &= \text{MIN}(10, 2,5*(12,5 - 0), 2,5*(10,16 - 0 - 0)) \\
 &= 10 \text{ mm}
 \end{aligned}$$

Nozzle required thickness per UG-27(c)(1)

$$\begin{aligned}
 t_{rn} &= P * R_n / (S_n * E - 0,6 * P) \\
 &= 21,0772 * 13,97 / (1,180 * 1 - 0,6 * 21,0772) \\
 &= 0,25 \text{ mm}
 \end{aligned}$$

Required thickness t_r from UG-37(a)

$$\begin{aligned}
 t_r &= P * R_o / (S * E + 0,4 * P) \\
 &= 21,0772 * 457,2 / (1,380 * 1 + 0,4 * 21,0772) \\
 &= 6,94 \text{ mm}
 \end{aligned}$$

This opening does not require reinforcement per UG-36(c)(3)(a)

UW-16(c) Weld Check

Fillet weld: t_{min} = lesser of 19 mm or t_n or t = 10,16 mm

t_{c(min)} = lesser of 6 mm or 0,7*t_{min} = 6 mm

t_{c(actual)} = 0,7*Leg = 0,7*9 = 6,3 mm

The fillet weld size is satisfactory.

Weld strength calculations are not required for this detail which conforms to Fig. UW-16.1, sketch (c-e).

UG-45 Nozzle Neck Thickness Check

$$\begin{aligned}t_{a \text{ UG-27}} &= P \cdot R_n / (S_n \cdot E - 0,6 \cdot P) + \text{Corrosion} \\ &= 21,0772 \cdot 13,97 / (1,180 \cdot 1 - 0,6 \cdot 21,0772) + 0 \\ &= 0,25 \text{ mm}\end{aligned}$$

$$\begin{aligned}t_a &= \max[t_{a \text{ UG-27}}, t_{a \text{ UG-22}}] \\ &= \max[0,25, 0] \\ &= 0,25 \text{ mm}\end{aligned}$$

$$\begin{aligned}t_{b1} &= P \cdot R_o / (S \cdot E + 0,4 \cdot P) + \text{Corrosion} \\ &= 21,0772 \cdot 457,2 / (1,380 \cdot 1 + 0,4 \cdot 21,0772) + 0 \\ &= 6,94 \text{ mm}\end{aligned}$$

$$\begin{aligned}t_{b1} &= \max[t_{b1}, t_{b \text{ UG16}}] \\ &= \max[6,94, 1,5] \\ &= 6,94 \text{ mm}\end{aligned}$$

$$\begin{aligned}t_b &= \min[t_{b3}, t_{b1}] \\ &= \min[3,22, 6,94] \\ &= 3,22 \text{ mm}\end{aligned}$$

$$\begin{aligned}t_{\text{UG-45}} &= \max[t_a, t_b] \\ &= \max[0,25, 3,22] \\ &= 3,22 \text{ mm}\end{aligned}$$

Available nozzle wall thickness new, $t_n = 0,875 \cdot 10,16 = 8,89 \text{ mm}$

The nozzle neck thickness is adequate.

Reinforcement check in the plane parallel to the longitudinal axis

Reinforcement Calculations for Internal Pressure

UG-37 Area Calculation Summary (cm ²)							UG-45 Summary (mm)	
For P = 21,08 bar @ 120 °C							The nozzle passes UG-45	
A required	A available	A ₁	A ₂	A ₃	A ₅	A welds	t _{req}	t _{min}
This nozzle is exempt from area calculations per UG-36(c)(3)(a)							3,22	8,89

UG-41 Weld Failure Path Analysis Summary
The nozzle is exempt from weld strength calculations per UW-15(b)(2)

UW-16 Weld Sizing Summary			
Weld description	Required weld throat size (mm)	Actual weld throat size (mm)	Status
Nozzle to shell fillet (Leg ₄₁)	6	6,3	weld size is adequate

Parallel Limit of reinforcement per UG-40

$$\begin{aligned}
 L_R &= \text{MAX}(d, R_n + (t_n - C_n) + (t - C)) \\
 &= \text{MAX}(27,94, 13,97 + (10,16 - 0) + (12,5 - 0)) \\
 &= 36,63 \text{ mm}
 \end{aligned}$$

Outer Normal Limit of reinforcement per UG-40

$$\begin{aligned}
 L_H &= \text{MIN}(2,5*(t - C), 2,5*(t_n - C_n) + t_e) \\
 &= \text{MIN}(2,5*(12,5 - 0), 2,5*(10,16 - 0) + 0) \\
 &= 25,4 \text{ mm}
 \end{aligned}$$

Inner Normal Limit of reinforcement per UG-40

$$\begin{aligned}
 L_I &= \text{MIN}(h, 2,5*(t - C), 2,5*(t_i - C_n - C)) \\
 &= \text{MIN}(10, 2,5*(12,5 - 0), 2,5*(10,16 - 0 - 0)) \\
 &= 10 \text{ mm}
 \end{aligned}$$

Nozzle required thickness per UG-27(c)(1)

$$\begin{aligned}
 t_{rn} &= P \cdot R_n / (S_n \cdot E - 0,6 \cdot P) \\
 &= 21,0772 \cdot 13,97 / (1,180 \cdot 1 - 0,6 \cdot 21,0772) \\
 &= 0,25 \text{ mm}
 \end{aligned}$$

Required thickness t_r from UG-37(a)

$$\begin{aligned}
 t_r &= P \cdot R_o / (S \cdot E + 0,4 \cdot P) \\
 &= 21,0772 \cdot 457,2 / (1,380 \cdot 1 + 0,4 \cdot 21,0772) \\
 &= 6,94 \text{ mm}
 \end{aligned}$$

This opening does not require reinforcement per UG-36(c)(3)(a)

UG-45 Nozzle Neck Thickness Check

$$\begin{aligned}
 t_{a \text{ UG-27}} &= P \cdot R_n / (S_n \cdot E - 0,6 \cdot P) + \text{Corrosion} \\
 &= 21,0772 \cdot 13,97 / (1,180 \cdot 1 - 0,6 \cdot 21,0772) + 0 \\
 &= 0,25 \text{ mm}
 \end{aligned}$$

$$\begin{aligned}
 t_a &= \text{max}[t_{a \text{ UG-27}}, t_{a \text{ UG-22}}] \\
 &= \text{max}[0,25, 0] \\
 &= 0,25 \text{ mm}
 \end{aligned}$$

$$\begin{aligned}
 t_{b1} &= P \cdot R_o / (S \cdot E + 0,4 \cdot P) + \text{Corrosion} \\
 &= 21,0772 \cdot 457,2 / (1,380 \cdot 1 + 0,4 \cdot 21,0772) + 0 \\
 &= 6,94 \text{ mm}
 \end{aligned}$$

$$\begin{aligned}
 t_{b1} &= \max[t_{b1} , t_{b \text{UG16}}] \\
 &= \max[6,94 , 1,5] \\
 &= 6,94 \text{ mm}
 \end{aligned}$$

$$\begin{aligned}
 t_b &= \min[t_{b3} , t_{b1}] \\
 &= \min[3,22 , 6,94] \\
 &= 3,22 \text{ mm}
 \end{aligned}$$

$$\begin{aligned}
 t_{\text{UG-45}} &= \max[t_a , t_b] \\
 &= \max[0,25 , 3,22] \\
 &= \underline{3,22} \text{ mm}
 \end{aligned}$$

Available nozzle wall thickness new, $t_n = 0,875 \cdot 10,16 = 8,89 \text{ mm}$

The nozzle neck thickness is adequate.

Coalescer Bleed (S)

ASME Section VIII Division 1, 2019 Edition Metric

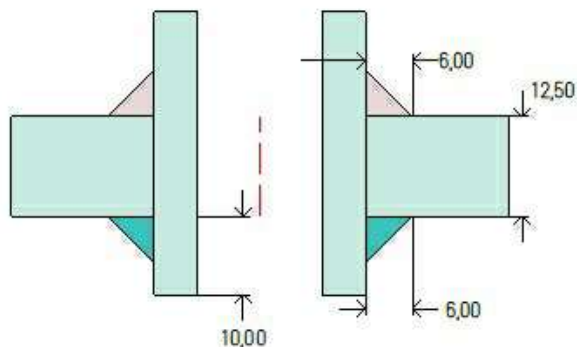

Note: round inside edges per UG-76(c)

Location and Orientation

Located on	Cylinder #1
Orientation	180°
Nozzle center line offset to datum line	863,6 mm
End of nozzle to shell center	659 mm
Passes through a Category A joint	No

Nozzle

Description	NPS 0,75 Sch 160 DN 20
Access opening	No
Material specification	SA-106 B Smls Pipe (II-D Metric p. 16, In. 10)
Inside diameter, new	15,54 mm
Pipe nominal wall thickness	5,56 mm
Pipe minimum wall thickness ¹	4,87 mm
Corrosion allowance	0 mm
Projection available outside vessel, L _{pr}	201,8 mm
Internal projection, h _{new}	10 mm
Local vessel minimum thickness	12,5 mm
Liquid static head included	0,09 bar
Longitudinal joint efficiency	1

Welds

Inner fillet, Leg ₄₁	6 mm
Lower fillet, Leg ₄₃	6 mm

¹Pipe minimum thickness = nominal thickness times pipe tolerance factor of 0,875.

UCS-66 Material Toughness Requirements Nozzle

Impact test exempt per UCS-66(d) (NPS 4 or smaller pipe) =	-105°C
Material is exempt from impact testing at the Design MDMT of -29°C.	

Reinforcement Calculations for Internal Pressure

UG-37 Area Calculation Summary (cm ²)							UG-45 Summary (mm)	
For P = 21,09 bar @ 120 °C							The nozzle passes UG-45	
A required	A available	A ₁	A ₂	A ₃	A ₅	A welds	t _{req}	t _{min}
This nozzle is exempt from area calculations per UG-36(c)(3)(a)							2,51	4,87

UG-41 Weld Failure Path Analysis Summary
The nozzle is exempt from weld strength calculations per UW-15(b)(2)

UW-16 Weld Sizing Summary			
Weld description	Required weld throat size (mm)	Actual weld throat size (mm)	Status
Nozzle to shell fillet (Leg ₄₁)	3,89	4,2	weld size is adequate
Nozzle to inside shell fillet (Leg ₄₃)	3,89	4,2	weld size is adequate
Combined weld check (t ₁ + t ₂)	6,95	8,4	weld size is adequate

Calculations for internal pressure 21,09 bar @ 120 °C

Parallel Limit of reinforcement per UG-40

$$\begin{aligned}
 L_R &= \text{MAX}(d, R_n + (t_n - C_n) + (t - C)) \\
 &= \text{MAX}(15,54, 7,77 + (5,56 - 0) + (12,5 - 0)) \\
 &= 25,84 \text{ mm}
 \end{aligned}$$

Outer Normal Limit of reinforcement per UG-40

$$\begin{aligned}
 L_H &= \text{MIN}(2,5*(t - C), 2,5*(t_n - C_n) + t_e) \\
 &= \text{MIN}(2,5*(12,5 - 0), 2,5*(5,56 - 0) + 0) \\
 &= 13,91 \text{ mm}
 \end{aligned}$$

Inner Normal Limit of reinforcement per UG-40

$$\begin{aligned}
 L_I &= \text{MIN}(h, 2,5*(t - C), 2,5*(t_i - C_n - C)) \\
 &= \text{MIN}(10, 2,5*(12,5 - 0), 2,5*(5,56 - 0 - 0)) \\
 &= 10 \text{ mm}
 \end{aligned}$$

Nozzle required thickness per UG-27(c)(1)

$$\begin{aligned}
 t_{rn} &= P * R_n / (S_n * E - 0,6 * P) \\
 &= 21,0896 * 7,77 / (1,180 * 1 - 0,6 * 21,0896) \\
 &= 0,14 \text{ mm}
 \end{aligned}$$

Required thickness t_r from UG-37(a)

$$\begin{aligned}
 t_r &= P * R_o / (S * E + 0,4 * P) \\
 &= 21,0896 * 457,2 / (1,380 * 1 + 0,4 * 21,0896) \\
 &= 6,94 \text{ mm}
 \end{aligned}$$

This opening does not require reinforcement per UG-36(c)(3)(a)

UW-16(d) Weld Check

$t_{\min} = \text{lesser of } 19 \text{ mm or } t_n \text{ or } t = 5,56 \text{ mm}$

$t_{1(\min)} \text{ or } t_{2(\min)} = \text{lesser of } 6 \text{ mm or } 0,7*t_{\min} = 3,89 \text{ mm}$

$t_{1(\text{actual})} = 0,7*\text{Leg} = 0,7*6 = 4,2 \text{ mm}$

The weld size t_1 is satisfactory.

$t_{2(\text{actual})} = 0,7*\text{Leg} = 0,7*6 = 4,2 \text{ mm}$

The weld size t_2 is satisfactory.

$t_1 + t_2 = 8,4 \geq 1,25*t_{\min} = 6,95$

The combined weld sizes for t_1 and t_2 are satisfactory.

UG-45 Nozzle Neck Thickness Check

$$\begin{aligned} t_{a \text{ UG-27}} &= P*R_n / (S_n*E - 0,6*P) + \text{Corrosion} \\ &= 21,1094*7,77 / (1.180*1 - 0,6*21,1094) + 0 \\ &= 0,14 \text{ mm} \end{aligned}$$

$$\begin{aligned} t_a &= \max[t_{a \text{ UG-27}} , t_{a \text{ UG-22}}] \\ &= \max[0,14 , 0] \\ &= 0,14 \text{ mm} \end{aligned}$$

$$\begin{aligned} t_{b1} &= P*R_o / (S*E + 0,4*P) + \text{Corrosion} \\ &= 21,0896*457,2 / (1.380*1 + 0,4*21,0896) + 0 \\ &= 6,94 \text{ mm} \end{aligned}$$

$$\begin{aligned} t_{b1} &= \max[t_{b1} , t_{b \text{ UG16}}] \\ &= \max[6,94 , 1,5] \\ &= 6,94 \text{ mm} \end{aligned}$$

$$\begin{aligned} t_b &= \min[t_{b3} , t_{b1}] \\ &= \min[2,51 , 6,94] \\ &= 2,51 \text{ mm} \end{aligned}$$

$$\begin{aligned} t_{\text{UG-45}} &= \max[t_a , t_b] \\ &= \max[0,14 , 2,51] \\ &= 2,51 \text{ mm} \end{aligned}$$

Available nozzle wall thickness new, $t_n = 0,875*5,56 = 4,87 \text{ mm}$

The nozzle neck thickness is adequate.

Oil Outlet (T)

ASME Section VIII Division 1, 2019 Edition Metric

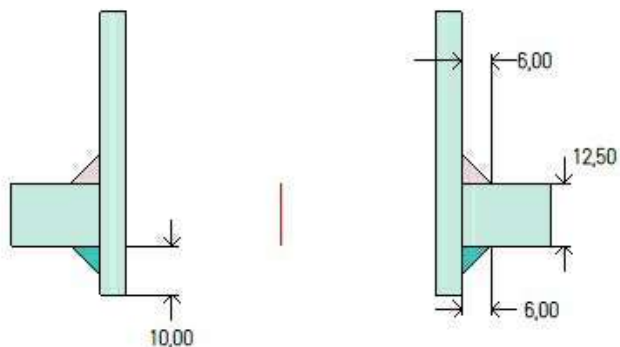

Note: round inside edges per UG-76(c)

Location and Orientation

Located on	Cylinder #1
Orientation	180°
Nozzle center line offset to datum line	1.422,4 mm
End of nozzle to shell center	786 mm
Passes through a Category A joint	No

Nozzle

Description	NPS 2,5 Sch 40 (Std) DN 65
Access opening	No
Material specification	SA-106 B Smls Pipe (II-D Metric p. 16, ln. 10)
Inside diameter, new	62,71 mm
Pipe nominal wall thickness	5,16 mm
Pipe minimum wall thickness ¹	4,51 mm
Corrosion allowance	0 mm
Projection available outside vessel, L _{pr}	328,8 mm
Internal projection, h _{new}	10 mm
Local vessel minimum thickness	12,5 mm
Liquid static head included	0,09 bar
Longitudinal joint efficiency	1

Welds

Inner fillet, Leg ₄₁	6 mm
Lower fillet, Leg ₄₃	6 mm

¹Pipe minimum thickness = nominal thickness times pipe tolerance factor of 0,875.

UCS-66 Material Toughness Requirements Nozzle

Impact test exempt per UCS-66(d) (NPS 4 or smaller pipe) =	-105°C
Material is exempt from impact testing at the Design MDMT of -29°C.	

Reinforcement Calculations for Internal Pressure

UG-37 Area Calculation Summary (cm ²)							UG-45 Summary (mm)	
For P = 21,09 bar @ 120 °C							The nozzle passes UG-45	
A required	A available	A ₁	A ₂	A ₃	A ₅	A welds	t _{req}	t _{min}
This nozzle is exempt from area calculations per UG-36(c)(3)(a)							4,51	4,51

UG-41 Weld Failure Path Analysis Summary
The nozzle is exempt from weld strength calculations per UW-15(b)(2)

UW-16 Weld Sizing Summary			
Weld description	Required weld throat size (mm)	Actual weld throat size (mm)	Status
Nozzle to shell fillet (Leg ₄₁)	3,61	4,2	weld size is adequate
Nozzle to inside shell fillet (Leg ₄₃)	3,61	4,2	weld size is adequate
Combined weld check (t ₁ + t ₂)	6,45	8,4	weld size is adequate

Calculations for internal pressure 21,09 bar @ 120 °C

Parallel Limit of reinforcement per UG-40

$$\begin{aligned}
 L_R &= \text{MAX}(d, R_n + (t_n - C_n) + (t - C)) \\
 &= \text{MAX}(62,71, 31,36 + (5,16 - 0) + (12,5 - 0)) \\
 &= 62,71 \text{ mm}
 \end{aligned}$$

Outer Normal Limit of reinforcement per UG-40

$$\begin{aligned}
 L_H &= \text{MIN}(2,5*(t - C), 2,5*(t_n - C_n) + t_e) \\
 &= \text{MIN}(2,5*(12,5 - 0), 2,5*(5,16 - 0) + 0) \\
 &= 12,89 \text{ mm}
 \end{aligned}$$

Inner Normal Limit of reinforcement per UG-40

$$\begin{aligned}
 L_I &= \text{MIN}(h, 2,5*(t - C), 2,5*(t_i - C_n - C)) \\
 &= \text{MIN}(10, 2,5*(12,5 - 0), 2,5*(5,16 - 0 - 0)) \\
 &= 10 \text{ mm}
 \end{aligned}$$

Nozzle required thickness per UG-27(c)(1)

$$\begin{aligned}
 t_{rn} &= P * R_n / (S_n * E - 0,6 * P) \\
 &= 21,0896 * 31,36 / (1,180 * 1 - 0,6 * 21,0896) \\
 &= 0,57 \text{ mm}
 \end{aligned}$$

Required thickness t_r from UG-37(a)

$$\begin{aligned}
 t_r &= P * R_o / (S * E + 0,4 * P) \\
 &= 21,0896 * 457,2 / (1,380 * 1 + 0,4 * 21,0896) \\
 &= 6,94 \text{ mm}
 \end{aligned}$$

This opening does not require reinforcement per UG-36(c)(3)(a)

UW-16(d) Weld Check

$t_{\min} = \text{lesser of } 19 \text{ mm or } t_n \text{ or } t = 5,16 \text{ mm}$

$t_{1(\min)} \text{ or } t_{2(\min)} = \text{lesser of } 6 \text{ mm or } 0,7*t_{\min} = 3,61 \text{ mm}$

$t_{1(\text{actual})} = 0,7*\text{Leg} = 0,7*6 = 4,2 \text{ mm}$

The weld size t_1 is satisfactory.

$t_{2(\text{actual})} = 0,7*\text{Leg} = 0,7*6 = 4,2 \text{ mm}$

The weld size t_2 is satisfactory.

$t_1 + t_2 = 8,4 \geq 1,25*t_{\min} = 6,45$

The combined weld sizes for t_1 and t_2 are satisfactory.

UG-45 Nozzle Neck Thickness Check

$$\begin{aligned} t_{a \text{ UG-27}} &= P*R_n / (S_n*E - 0,6*P) + \text{Corrosion} \\ &= 21,1218*31,36 / (1.180*1 - 0,6*21,1218) + 0 \\ &= 0,57 \text{ mm} \end{aligned}$$

$$\begin{aligned} t_a &= \max[t_{a \text{ UG-27}} , t_{a \text{ UG-22}}] \\ &= \max[0,57 , 0] \\ &= 0,57 \text{ mm} \end{aligned}$$

$$\begin{aligned} t_{b1} &= P*R_o / (S*E + 0,4*P) + \text{Corrosion} \\ &= 21,0896*457,2 / (1.380*1 + 0,4*21,0896) + 0 \\ &= 6,94 \text{ mm} \end{aligned}$$

$$\begin{aligned} t_{b1} &= \max[t_{b1} , t_{b \text{ UG16}}] \\ &= \max[6,94 , 1,5] \\ &= 6,94 \text{ mm} \end{aligned}$$

$$\begin{aligned} t_b &= \min[t_{b3} , t_{b1}] \\ &= \min[4,51 , 6,94] \\ &= 4,51 \text{ mm} \end{aligned}$$

$$\begin{aligned} t_{\text{UG-45}} &= \max[t_a , t_b] \\ &= \max[0,57 , 4,51] \\ &= 4,51 \text{ mm} \end{aligned}$$

Available nozzle wall thickness new, $t_n = 0,875*5,16 = 4,51 \text{ mm}$

The nozzle neck thickness is adequate.

Access Opening (MW)

ASME Section VIII Division 1, 2019 Edition Metric

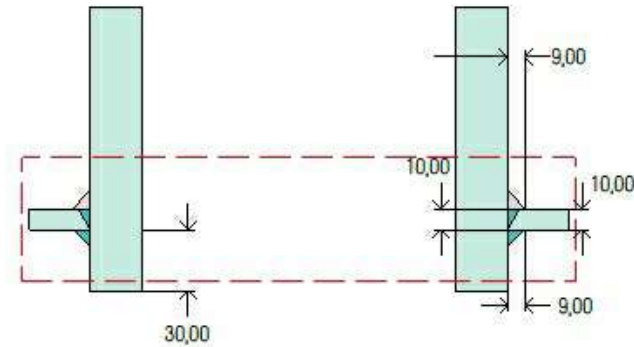

Note: round inside edges per UG-76(c)

Location and Orientation

Located on	Ellipsoidal Head #2
Orientation	0°
End of nozzle to datum line	-311 mm
Calculated as hillside	No
Distance to head center, R	0 mm
Passes through a Category A joint	No

Nozzle

Description	456 mm x 355 mm Elliptical Nozzle
Access opening	Yes
Material specification	SA-106 B Smls Pipe (II-D Metric p. 16, In. 10)
Inside diameter, new	456 mm
Pipe nominal wall thickness	25 mm
Pipe minimum wall thickness ¹	21,88 mm
Corrosion allowance	0 mm
Projection available outside vessel, L _{pr}	64,96 mm
Internal projection, h _{new}	30 mm
Local vessel minimum thickness	10 mm
Liquid static head included	0,04 bar
Longitudinal joint efficiency	1

Welds

Inner fillet, Leg ₄₁	9 mm
Lower fillet, Leg ₄₃	9 mm
Nozzle to vessel groove weld	10 mm

¹Pipe minimum thickness = nominal thickness times pipe tolerance factor of 0,875.

UCS-66 Material Toughness Requirements Nozzle	
$t_r = 21,04 \cdot 228 / (1.180 \cdot 1 - 0,6 \cdot 21,04) =$	4,11 mm
Stress ratio = $t_r \cdot E^* / (t_n - c) = 4,11 \cdot 1 / (21,88 - 0) =$	0,1879
Stress ratio $\leq 0,35$, MDMT per UCS-66(b)(3) =	-105°C
Material is exempt from impact testing at the Design MDMT of -29°C.	

Reinforcement Calculations for Internal Pressure

UG-37 Area Calculation Summary (cm ²)							UG-45 Summary (mm)	
For P = 21,04 bar @ 120 °C The opening is adequately reinforced							The nozzle passes UG-45	
A required	A available	A ₁	A ₂	A ₃	A ₅	A welds	t _{req}	t _{min}
31,4634	35,4022	14,3961	8,9316	10,6888	-	1,3858	4,11	21,88

UG-41 Weld Failure Path Analysis Summary
The nozzle is exempt from weld strength calculations per UW-15(b)(1)

UW-16 Weld Sizing Summary			
Weld description	Required weld throat size (mm)	Actual weld throat size (mm)	Status
Nozzle to shell fillet (Leg ₄₁)	6	6,3	weld size is adequate

Calculations for internal pressure 21,04 bar @ 120 °C

Parallel Limit of reinforcement per UG-40

$$\begin{aligned}
 L_R &= \text{MAX}(d, R_n + (t_n - C_n) + (t - C)) \\
 &= \text{MAX}(456, 228 + (25 - 0) + (10 - 0)) \\
 &= 456 \text{ mm}
 \end{aligned}$$

Outer Normal Limit of reinforcement per UG-40

$$\begin{aligned}
 L_H &= \text{MIN}(2,5*(t - C), 2,5*(t_n - C_n) + t_e) \\
 &= \text{MIN}(2,5*(10 - 0), 2,5*(25 - 0) + 0) \\
 &= 25 \text{ mm}
 \end{aligned}$$

Inner Normal Limit of reinforcement per UG-40

$$\begin{aligned}
 L_I &= \text{MIN}(h, 2,5*(t - C), 2,5*(t_i - C_n - C)) \\
 &= \text{MIN}(30, 2,5*(10 - 0), 2,5*(25 - 0 - 0)) \\
 &= 25 \text{ mm}
 \end{aligned}$$

Nozzle required thickness per UG-27(c)(1)

$$\begin{aligned}
 t_{rn} &= P * R_n / (S_n * E - 0,6 * P) \\
 &= 21,0448 * 228 / (1.180 * 1 - 0,6 * 21,0448) \\
 &= 4,11 \text{ mm}
 \end{aligned}$$

Required thickness t_r from UG-37(a)

$$\begin{aligned}
 t_r &= P * D / (2 * S * E - 0,2 * P) \\
 &= 21,04 * 889,4 / (2 * 1.380 * 1 - 0,2 * 21,04) \\
 &= 6,79 \text{ mm}
 \end{aligned}$$

Area required per UG-37(c)

Allowable stresses: S_n = 1.203,265, S_v = 1.407,208 kgf/cm²

$$f_{r1} = \text{lesser of } 1 \text{ or } S_n / S_v = 0,8551$$

$$f_{r2} = \text{lesser of } 1 \text{ or } S_n / S_v = 0,8551$$

$$\begin{aligned}
 A &= d * t_r * F + 2 * t_n * t_r * F * (1 - f_{r1}) \\
 &= (456 * 6,79 * 1 + 2 * 25 * 6,79 * 1 * (1 - 0,8551)) / 100 \\
 &= [31,4634](#) \text{ cm}^2
 \end{aligned}$$

Area available from FIG. UG-37.1

A_1 = larger of the following= [14,3961](#) cm²

$$\begin{aligned} &= d(E_1 t - F t_r) - 2 t_n (E_1 t - F t_r) (1 - f_{r1}) \\ &= (456(1 \cdot 10 - 1 \cdot 6,79) - 2 \cdot 25(1 \cdot 10 - 1 \cdot 6,79)(1 - 0,8551)) / 100 \\ &= 14,3961 \text{ cm}^2 \\ &= 2(t + t_n)(E_1 t - F t_r) - 2 t_n (E_1 t - F t_r) (1 - f_{r1}) \\ &= (2(10 + 25)(1 \cdot 10 - 1 \cdot 6,79) - 2 \cdot 25(1 \cdot 10 - 1 \cdot 6,79)(1 - 0,8551)) / 100 \\ &= 2,0129 \text{ cm}^2 \end{aligned}$$

A_2 = smaller of the following= [8,9316](#) cm²

$$\begin{aligned} &= 5(t_n - t_{rn}) f_{r2} t \\ &= (5(25 - 4,11) \cdot 0,8551 \cdot 10) / 100 \\ &= 8,9316 \text{ cm}^2 \\ &= 5(t_n - t_{rn}) f_{r2} t_n \\ &= (5(25 - 4,11) \cdot 0,8551 \cdot 25) / 100 \\ &= 22,329 \text{ cm}^2 \end{aligned}$$

A_3 = smaller of the following= [10,6888](#) cm²

$$\begin{aligned} &= 5 t^2 f_{r2} \\ &= (5 \cdot 10^2 \cdot 25 \cdot 0,8551) / 100 \\ &= [10,6888](#) \text{ cm}^2 \\ &= 5 t_n^2 f_{r2} \\ &= (5 \cdot 25^2 \cdot 25 \cdot 0,8551) / 100 \\ &= [26,7219](#) \text{ cm}^2 \\ &= 2 h t_n f_{r2} \\ &= (2 \cdot 30 \cdot 25 \cdot 0,8551) / 100 \\ &= [12,8265](#) \text{ cm}^2 \end{aligned}$$

$$\begin{aligned} A_{41} &= \text{Leg}^2 f_{r2} \\ &= (9^2 \cdot 0,8551) / 100 \\ &= [0,6929](#) \text{ cm}^2 \end{aligned}$$

$$\begin{aligned} A_{43} &= \text{Leg}^2 f_{r2} \\ &= (9^2 \cdot 0,8551) / 100 \\ &= [0,6929](#) \text{ cm}^2 \end{aligned}$$

$$\begin{aligned} \text{Area} &= A_1 + A_2 + A_3 + A_{41} + A_{43} \\ &= 14,3961 + 8,9316 + 10,6888 + 0,6929 + 0,6929 \\ &= [35,4022](#) \text{ cm}^2 \end{aligned}$$

As Area \geq A the reinforcement is adequate.

UW-16(c) Weld Check

Fillet weld: t_{\min} = lesser of 19 mm or t_n or $t = 10$ mm

$t_{c(\min)}$ = lesser of 6 mm or $0,7 \cdot t_{\min} = [6](#) mm$

$t_{c(\text{actual})} = 0,7 \cdot \text{Leg} = 0,7 \cdot 9 = 6,3$ mm

The fillet weld size is satisfactory.

Weld strength calculations are not required for this detail which conforms to Fig. UW-16.1, sketch (c-e).

UG-45 Nozzle Neck Thickness Check (Access Opening)

$$\begin{aligned}
 t_{a \text{ UG-27}} &= P \cdot R_n / (S_n \cdot E - 0,6 \cdot P) + \text{Corrosion} \\
 &= 21,0448 \cdot 228 / (1.180 \cdot 1 - 0,6 \cdot 21,0448) + 0 \\
 &= 4,11 \text{ mm}
 \end{aligned}$$

$$\begin{aligned}
 t_a &= \max[t_{a \text{ UG-27}}, t_{a \text{ UG-22}}] \\
 &= \max[4,11, 0] \\
 &= 4,11 \text{ mm}
 \end{aligned}$$

Available nozzle wall thickness new, $t_n = 0,875 \cdot 25 = 21,88 \text{ mm}$

The nozzle neck thickness is adequate.

Cylinder #1

ASME Section VIII Division 1, 2019 Edition Metric				
Component		Cylinder		
Material		SA-516 70 (II-D Metric p. 20, ln. 33)		
Impact Tested	Normalized	Fine Grain Practice	PWHT	Maximize MDMT/ No MAWP
No	No	No	No	No
		Design Pressure (bar)	Design Temperature (°C)	Design MDMT (°C)
Internal		21	120	-29
Static Liquid Head				
Condition		P_s (bar)	H_s (mm)	SG
Operating		0,09	901,7	1
Test horizontal		0,11	1.081,61	1
Dimensions				
Outer Diameter		914,4 mm		
Length		3.505,2 mm		
Nominal Thickness		12,5 mm		
Corrosion	Inner	0 mm		
	Outer	0 mm		
Weight and Capacity				
		Weight (kg)	Capacity (liters)	
New		960,9	2.177,69	
Corroded		960,9	2.177,69	
Radiography				
Longitudinal seam		None UW-11(c) Type 1		
Left Circumferential seam		None UW-11(c) Type 1		
Right Circumferential seam		None UW-11(c) Type 1		

Results Summary	
Governing condition	Internal pressure
Minimum thickness per UG-16	1,5 mm + 0 mm = 1,5 mm
Design thickness due to internal pressure (t)	9.9 mm
Maximum allowable working pressure (MAWP)	26.61 bar
Maximum allowable pressure (MAP)	26.7 bar
Rated MDMT	-42,88 °C

UCS-66 Material Toughness Requirements	
Governing thickness, $t_g =$	12,5 mm
Exemption temperature from Fig UCS-66M Curve B =	-22,38°C
$t_r = 21,09 \cdot 457,2 / (1.380 \cdot 0,7 + 0.4 \cdot 21,09) =$	9,89 mm
Stress ratio = $t_r \cdot E^* / (t_n - c) = 9,89 \cdot 0,8 / (12,5 - 0) =$	0,6333
Reduction in MDMT, T_R from Fig UCS-66.1M =	20,5°C
MDMT = $\max[\text{MDMT} - T_R, -48] = \max[-22,38 - 20,5, -48] =$	-42,88°C
Material is exempt from impact testing at the Design MDMT of -29°C.	

Design thickness, (at 120 °C) Appendix 1-1

$$\begin{aligned}
 t &= P \cdot R_o / (S \cdot E + 0,40 \cdot P) + \text{Corrosion} \\
 &= 21,09 \cdot 457,2 / (1.380 \cdot 0,70 + 0,40 \cdot 21,09) + 0 \\
 &= \underline{9,9} \text{ mm}
 \end{aligned}$$

Maximum allowable working pressure, (at 120 °C) Appendix 1-1

$$\begin{aligned}
 P &= S \cdot E \cdot t / (R_o - 0,40 \cdot t) - P_s \\
 &= 1.380 \cdot 0,70 \cdot 12,5 / (457,2 - 0,40 \cdot 12,5) - 0,09 \\
 &= \underline{26,61} \text{ bar}
 \end{aligned}$$

Maximum allowable pressure, (at 21,11 °C) Appendix 1-1

$$\begin{aligned}
 P &= S \cdot E \cdot t / (R_o - 0,40 \cdot t) \\
 &= 1.380 \cdot 0,70 \cdot 12,5 / (457,2 - 0,40 \cdot 12,5) \\
 &= \underline{26,7} \text{ bar}
 \end{aligned}$$

% Extreme fiber elongation - UCS-79(d)

$$\begin{aligned}
 EFE &= (50 \cdot t / R_f) \cdot (1 - R_f / R_o) \\
 &= (50 \cdot 12,5 / 450,95) \cdot (1 - 450,95 / \text{infinity}) \\
 &= 1,386\%
 \end{aligned}$$

The extreme fiber elongation does not exceed 5%.

Oil Drain (W)

ASME Section VIII Division 1, 2019 Edition Metric

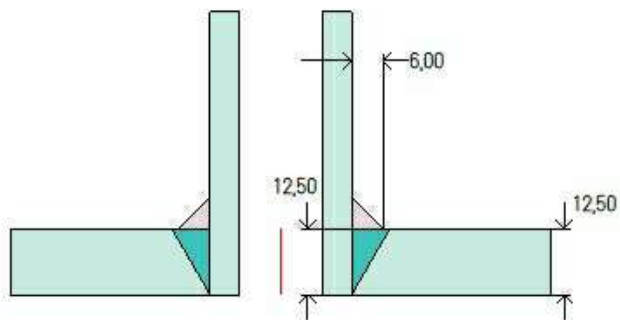

Note: round inside edges per UG-76(c)

Location and Orientation

Located on	Cylinder #1
Orientation	180°
Nozzle center line offset to datum line	2.235,2 mm
End of nozzle to shell center	546 mm
Passes through a Category A joint	No

Nozzle

Description	NPS 0,75 Sch 160 DN 20
Access opening	No
Material specification	SA-106 B Smls Pipe (II-D Metric p. 16, ln. 10)
Inside diameter, new	15,54 mm
Pipe nominal wall thickness	5,56 mm
Pipe minimum wall thickness¹	4,87 mm
Corrosion allowance	0 mm
Projection available outside vessel, L_{pr}	88,8 mm
Local vessel minimum thickness	12,5 mm
Liquid static head included	0,09 bar
Longitudinal joint efficiency	1

Welds

Inner fillet, Leg₄₁	6 mm
Nozzle to vessel groove weld	12,5 mm

¹Pipe minimum thickness = nominal thickness times pipe tolerance factor of 0,875.

UCS-66 Material Toughness Requirements Nozzle

Impact test exempt per UCS-66(d) (NPS 4 or smaller pipe) =	-105°C
Material is exempt from impact testing at the Design MDMT of -29°C.	

Reinforcement Calculations for Internal Pressure

UG-37 Area Calculation Summary (cm ²)							UG-45 Summary (mm)	
For P = 21,09 bar @ 120 °C							The nozzle passes UG-45	
A required	A available	A ₁	A ₂	A ₃	A ₅	A welds	t _{req}	t _{min}
This nozzle is exempt from area calculations per UG-36(c)(3)(a)							2,51	4,87

UG-41 Weld Failure Path Analysis Summary
The nozzle is exempt from weld strength calculations per UW-15(b)(2)

UW-16 Weld Sizing Summary			
Weld description	Required weld throat size (mm)	Actual weld throat size (mm)	Status
Nozzle to shell fillet (Leg ₄₁)	3,89	4,2	weld size is adequate

Calculations for internal pressure 21,09 bar @ 120 °C

Parallel Limit of reinforcement per UG-40

$$\begin{aligned}
 L_R &= \text{MAX}(d, R_n + (t_n - C_n) + (t - C)) \\
 &= \text{MAX}(15,54, 7,77 + (5,56 - 0) + (12,5 - 0)) \\
 &= 25,84 \text{ mm}
 \end{aligned}$$

Outer Normal Limit of reinforcement per UG-40

$$\begin{aligned}
 L_H &= \text{MIN}(2,5*(t - C), 2,5*(t_n - C_n) + t_e) \\
 &= \text{MIN}(2,5*(12,5 - 0), 2,5*(5,56 - 0) + 0) \\
 &= 13,91 \text{ mm}
 \end{aligned}$$

Nozzle required thickness per UG-27(c)(1)

$$\begin{aligned}
 t_{rn} &= P * R_n / (S_n * E - 0,6 * P) \\
 &= 21,0896 * 7,77 / (1,180 * 1 - 0,6 * 21,0896) \\
 &= 0,14 \text{ mm}
 \end{aligned}$$

Required thickness t_r from UG-37(a)

$$\begin{aligned}
 t_r &= P * R_o / (S * E + 0,4 * P) \\
 &= 21,0896 * 457,2 / (1,380 * 1 + 0,4 * 21,0896) \\
 &= 6,94 \text{ mm}
 \end{aligned}$$

This opening does not require reinforcement per UG-36(c)(3)(a)

UW-16(c) Weld Check

Fillet weld: t_{min} = lesser of 19 mm or t_n or t = 5,56 mm

t_{c(min)} = lesser of 6 mm or 0,7*t_{min} = 3,89 mm

t_{c(actual)} = 0,7*Leg = 0,7*6 = 4,2 mm

The fillet weld size is satisfactory.

Weld strength calculations are not required for this detail which conforms to Fig. UW-16.1, sketch (c-e).

UG-45 Nozzle Neck Thickness Check

$$\begin{aligned}
 t_{a \text{ UG-27}} &= P * R_n / (S_n * E - 0,6 * P) + \text{Corrosion} \\
 &= 21,0983 * 7,77 / (1,180 * 1 - 0,6 * 21,0983) + 0 \\
 &= 0,14 \text{ mm}
 \end{aligned}$$

$$\begin{aligned}
 t_a &= \max[t_{a \text{ UG-27}}, t_{a \text{ UG-22}}] \\
 &= \max[0,14, 0] \\
 &= 0,14 \text{ mm}
 \end{aligned}$$

$$\begin{aligned}
 t_{b1} &= P \cdot R_o / (S \cdot E + 0,4 \cdot P) + \text{Corrosion} \\
 &= 21,0896 \cdot 457,2 / (1,380 \cdot 1 + 0,4 \cdot 21,0896) + 0 \\
 &= 6,94 \text{ mm}
 \end{aligned}$$

$$\begin{aligned}
 t_{b1} &= \max[t_{b1}, t_{b \text{ UG16}}] \\
 &= \max[6,94, 1,5] \\
 &= 6,94 \text{ mm}
 \end{aligned}$$

$$\begin{aligned}
 t_b &= \min[t_{b3}, t_{b1}] \\
 &= \min[2,51, 6,94] \\
 &= 2,51 \text{ mm}
 \end{aligned}$$

$$\begin{aligned}
 t_{\text{UG-45}} &= \max[t_a, t_b] \\
 &= \max[0,14, 2,51] \\
 &= \underline{2,51} \text{ mm}
 \end{aligned}$$

Available nozzle wall thickness new, $t_n = 0,875 \cdot 5,56 = 4,87 \text{ mm}$

The nozzle neck thickness is adequate.

Still Chamber (SC)

ASME Section VIII Division 1, 2019 Edition Metric

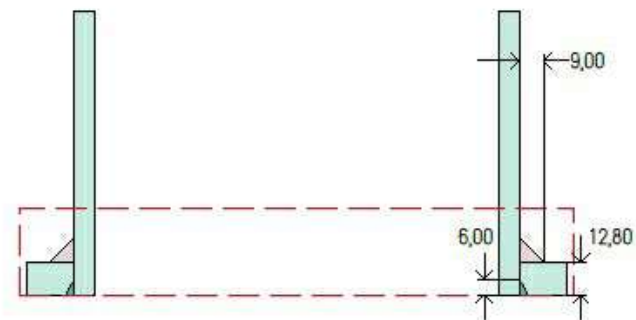

Note: round inside edges per UG-76(c)

Location and Orientation

Located on	Cylinder #1
Orientation	90°
Nozzle center line offset to datum line	1.930,4 mm
End of nozzle to shell center	508 mm
Offset from center, Lo	222,25 mm
Passes through a Category A joint	No

Nozzle

Description	NPS 8 Sch 40 (Std) DN 200
Access opening	No
Material specification	SA-106 B Smls Pipe (II-D Metric p. 16, ln. 10)
Inside diameter, new	202,72 mm
Pipe nominal wall thickness	8,18 mm
Pipe minimum wall thickness ¹	7,16 mm
Corrosion allowance	0 mm
Opening chord length	236,34 mm
Projection available outside vessel, Lpr	64,91 mm
User input vessel thickness	12,8 mm
Liquid static head included	0,07 bar
Longitudinal joint efficiency	1

Welds

Inner fillet, Leg ₄₁	9 mm
Nozzle to vessel groove weld	6 mm

¹Pipe minimum thickness = nominal thickness times pipe tolerance factor of 0,875.

UCS-66 Material Toughness Requirements Nozzle	
$t_r = 21,07 \cdot 101,36 / (1.180 \cdot 1 - 0,6 \cdot 21,07) =$	1,83 mm
Stress ratio = $t_r \cdot E^* / (t_n - c) = 1,83 \cdot 1 / (7,16 - 0) =$	0,2556
Stress ratio $\leq 0,35$, MDMT per UCS-66(b)(3) =	-105°C
Material is exempt from impact testing at the Design MDMT of -29°C.	

Reinforcement Calculations for Internal Pressure

UG-37 Area Calculation Summary (cm ²)							UG-45 Summary (mm)	
For P = 21,07 bar @ 120 °C The opening is adequately reinforced							The nozzle passes UG-45	
A required	A available	A ₁	A ₂	A ₃	A ₅	A welds	t _{req}	t _{min}
16.5594	16.6316	13.718	2.2206	-	-	0.6929	6.94	7,16

UG-41 Weld Failure Path Analysis Summary (kg _f)				
All failure paths are stronger than the applicable weld loads				
Weld load W	Weld load W ₁₋₁	Path 1-1 strength	Weld load W ₂₋₂	Path 2-2 strength
5.152	4.100	41.082	6.619	39.761

UW-16 Weld Sizing Summary			
Weld description	Required weld size (mm)	Actual weld size (mm)	Status
Nozzle to shell fillet (Leg ₄₁)	5.73	6,3	weld size is adequate
Combined weld check (t ₁ + t ₂)	10.22	12,3	weld size is adequate
Nozzle to shell groove (Lower)	5.73	6	weld size is adequate

Calculations for internal pressure 21,07 bar @ 120 °C

Parallel Limit of reinforcement per UG-40

$$\begin{aligned}
 L_R &= \text{MAX}(d, R_n + (t_n - C_n) + (t - C)) \\
 &= \text{MAX}(236,34, 118,17 + (8,18 - 0) + (12,8 - 0)) \\
 &= 236,34 \text{ mm}
 \end{aligned}$$

Outer Normal Limit of reinforcement per UG-40

$$\begin{aligned}
 L_H &= \text{MIN}(2,5*(t - C), 2,5*(t_n - C_n) + t_e) \\
 &= \text{MIN}(2,5*(12,8 - 0), 2,5*(8,18 - 0) + 0) \\
 &= 20,45 \text{ mm}
 \end{aligned}$$

Nozzle required thickness per UG-27(c)(1)

$$\begin{aligned}
 t_{rn} &= P * R_n / (S_n * E - 0,6 * P) \\
 &= 21,0666 * 101,36 / (1.180 * 1 - 0,6 * 21,0666) \\
 &= 1,83 \text{ mm}
 \end{aligned}$$

Required thickness t_r from UG-37(a)

$$\begin{aligned}
 t_r &= P * R_o / (S * E + 0,4 * P) \\
 &= 21,0666 * 457,2 / (1.380 * 1 + 0,4 * 21,0666) \\
 &= 6,94 \text{ mm}
 \end{aligned}$$

Area required per UG-37(c)

Allowable stresses: S_n = 1.203,265, S_v = 1.407,208 kg_f/cm²

$$f_{r1} = \text{lesser of } 1 \text{ or } S_n / S_v = 0,8551$$

$$f_{r2} = \text{lesser of } 1 \text{ or } S_n / S_v = 0,8551$$

$$\begin{aligned}
A &= d \cdot t_r \cdot F + 2 \cdot t_n \cdot t_r \cdot F \cdot (1 - f_{r1}) \\
&= (236,34 \cdot 6,94 \cdot 1 + 2 \cdot 8,18 \cdot 6,94 \cdot 1 \cdot (1 - 0,8551)) / 100 \\
&= \underline{16,5594} \text{ cm}^2
\end{aligned}$$

Area available from FIG. UG-37.1

$$A_1 = \text{larger of the following} = \underline{13,718} \text{ cm}^2$$

$$\begin{aligned}
&= d \cdot (E_1 \cdot t - F \cdot t_r) - 2 \cdot t_n \cdot (E_1 \cdot t - F \cdot t_r) \cdot (1 - f_{r1}) \\
&= (236,34 \cdot (1 \cdot 12,8 - 1 \cdot 6,94) - 2 \cdot 8,18 \cdot (1 \cdot 12,8 - 1 \cdot 6,94) \cdot (1 - 0,8551)) / 100 \\
&= 13,718 \text{ cm}^2 \\
&= 2 \cdot (t + t_n) \cdot (E_1 \cdot t - F \cdot t_r) - 2 \cdot t_n \cdot (E_1 \cdot t - F \cdot t_r) \cdot (1 - f_{r1}) \\
&= (2 \cdot (12,8 + 8,18) \cdot (1 \cdot 12,8 - 1 \cdot 6,94) - 2 \cdot 8,18 \cdot (1 \cdot 12,8 - 1 \cdot 6,94) \cdot (1 - 0,8551)) / 100 \\
&= 2,3213 \text{ cm}^2
\end{aligned}$$

$$A_2 = \text{smaller of the following} = \underline{2,2206} \text{ cm}^2$$

$$\begin{aligned}
&= 5 \cdot (t_n - t_{rn}) \cdot f_{r2} \cdot t \\
&= (5 \cdot (8,18 - 1,83) \cdot 0,8551 \cdot 12,8) / 100 \\
&= 3,4748 \text{ cm}^2 \\
&= 5 \cdot (t_n - t_{rn}) \cdot f_{r2} \cdot t_n \\
&= (5 \cdot (8,18 - 1,83) \cdot 0,8551 \cdot 8,18) / 100 \\
&= 2,2206 \text{ cm}^2
\end{aligned}$$

$$\begin{aligned}
A_{41} &= \text{Leg}^2 \cdot f_{r2} \\
&= (9^2 \cdot 0,8551) / 100 \\
&= \underline{0,6929} \text{ cm}^2
\end{aligned}$$

$$\begin{aligned}
\text{Area} &= A_1 + A_2 + A_{41} \\
&= 13,718 + 2,2206 + 0,6929 \\
&= \underline{16,6316} \text{ cm}^2
\end{aligned}$$

As Area \geq A the reinforcement is adequate.

UW-16(d) Weld Check

$$\begin{aligned}
t_{\min} &= \text{lesser of } 19 \text{ mm or } t_n \text{ or } t = 8,18 \text{ mm} \\
t_{1(\min)} \text{ or } t_{2(\min)} &= \text{lesser of } 6 \text{ mm or } 0,7 \cdot t_{\min} = \underline{5,73} \text{ mm} \\
t_{1(\text{actual})} &= 0,7 \cdot \text{Leg} = 0,7 \cdot 9 = 6,3 \text{ mm} \\
&\text{The weld size } t_1 \text{ is satisfactory.} \\
t_{2(\text{actual})} &= 6 \text{ mm} \\
&\text{The weld size } t_2 \text{ is satisfactory.}
\end{aligned}$$

$$t_1 + t_2 = 12,3 \geq 1,25 \cdot t_{\min} = \underline{10,22}$$

The combined weld sizes for t_1 and t_2 are satisfactory.

UG-45 Nozzle Neck Thickness Check

$$\begin{aligned}
t_{a \text{ UG-27}} &= P \cdot R_n / (S_n \cdot E - 0,6 \cdot P) + \text{Corrosion} \\
&= 21,0666 \cdot 101,36 / (1,180 \cdot 1 - 0,6 \cdot 21,0666) + 0 \\
&= 1,83 \text{ mm}
\end{aligned}$$

$$\begin{aligned}
t_a &= \max[t_{a \text{ UG-27}} , t_{a \text{ UG-22}}] \\
&= \max[1,83 , 0] \\
&= 1,83 \text{ mm}
\end{aligned}$$

$$\begin{aligned}
t_{b1} &= P \cdot R_o / (S \cdot E + 0,4 \cdot P) + \text{Corrosion} \\
&= 21,0666 \cdot 457,2 / (1,380 \cdot 1 + 0,4 \cdot 21,0666) + 0 \\
&= 6,94 \text{ mm}
\end{aligned}$$

$$\begin{aligned}
 t_{b1} &= \max[t_{b1} , t_{b \text{ UG16}}] \\
 &= \max[6,94 , 1,5] \\
 &= 6,94 \text{ mm}
 \end{aligned}$$

$$\begin{aligned}
 t_b &= \min[t_{b3} , t_{b1}] \\
 &= \min[7,16 , 6,94] \\
 &= 6,94 \text{ mm}
 \end{aligned}$$

$$\begin{aligned}
 t_{\text{UG-45}} &= \max[t_a , t_b] \\
 &= \max[1,83 , 6,94] \\
 &= \underline{6,94} \text{ mm}
 \end{aligned}$$

Available nozzle wall thickness new, $t_n = 0,875 \cdot 8,18 = 7,16 \text{ mm}$

The nozzle neck thickness is adequate.

Allowable stresses in joints UG-45 and UW-15(c)

Groove weld in tension: $0,74 \cdot 1.407,208 = 1.041,334 \text{ kg}_f/\text{cm}^2$

Nozzle wall in shear: $0,7 \cdot 1.203,265 = 842,286 \text{ kg}_f/\text{cm}^2$

Inner fillet weld in shear: $0,49 \cdot 1.203,265 = 589,6 \text{ kg}_f/\text{cm}^2$

Strength of welded joints:

(1) Inner fillet weld in shear

$$(\pi / 2) \cdot \text{Nozzle OD} \cdot \text{Leg} \cdot S_i = (\pi / 2) \cdot 219,08 \cdot 9 \cdot 589,6 = 18.260,5 \text{ kg}_f$$

(3) Nozzle wall in shear

$$(\pi / 2) \cdot \text{Mean nozzle dia} \cdot t_n \cdot S_n = (\pi / 2) \cdot 210,9 \cdot 8,18 \cdot 842,286 = 22.821,16 \text{ kg}_f$$

(4) Groove weld in tension

$$(\pi / 2) \cdot \text{Nozzle OD} \cdot t_w \cdot S_g = (\pi / 2) \cdot 219,08 \cdot 6 \cdot 1.041,334 = 21.500,78 \text{ kg}_f$$

Loading on welds per UG-41(b)(1)

$$\begin{aligned}
 W &= (A - A_1 + 2 \cdot t_n \cdot t_{r1} \cdot (E_1 \cdot t - F \cdot t_r)) \cdot S_v \\
 &= (1.655,9447 - 1.371,8037 + 2 \cdot 8,18 \cdot 0,8551 \cdot (1 \cdot 12,8 - 1 \cdot 6,94)) \cdot 1.407,208 \\
 &= \underline{5.152,48} \text{ kg}_f
 \end{aligned}$$

$$\begin{aligned}
 W_{1-1} &= (A_2 + A_5 + A_{41} + A_{42}) \cdot S_v \\
 &= (222,0641 + 0 + 69,2902 + 0) \cdot 1.407,208 \\
 &= \underline{4.099,96} \text{ kg}_f
 \end{aligned}$$

$$\begin{aligned}
 W_{2-2} &= (A_2 + A_3 + A_{41} + A_{43} + 2 \cdot t_n \cdot t_{r1}) \cdot S_v \\
 &= (222,0641 + 0 + 69,2902 + 0 + 2 \cdot 8,18 \cdot 12,8 \cdot 0,8551) \cdot 1.407,208 \\
 &= \underline{6.619,41} \text{ kg}_f
 \end{aligned}$$

Load for path 1-1 lesser of W or $W_{1-1} = 4.099,96 \text{ kg}_f$

Path 1-1 through (1) & (3) = $18.260,5 + 22.821,16 = \underline{41.081,66} \text{ kg}_f$

Path 1-1 is stronger than W_{1-1} so it is acceptable per UG-41(b)(1).

Load for path 2-2 lesser of W or $W_{2-2} = 5.152,48 \text{ kg}_f$

Path 2-2 through (1), (4) = $18.260,5 + 21.500,78 = \underline{39.761,28} \text{ kg}_f$

Path 2-2 is stronger than W so it is acceptable per UG-41(b)(2).

Welded Cover #1

ASME Section VIII Division 1, 2019 Edition Metric				
Component		Welded Cover		
Configuration		Figure UG-34 Sketch (h)		
Weld Detail		Figure UW-13.2 Sketch (d)		
Material		SA-516 70 (II-D Metric p. 20, ln. 33)		
Attached To		Still Chamber (SC)		
Impact Tested	Normalized	Fine Grain Practice	PWHT	Maximize MDMT/ No MAWP
No	No	No	No	No
		Design Pressure (bar)	Design Temperature (°C)	Design MDMT (°C)
Internal		21	120	-29
Static Liquid Head				
Condition		P_s (bar)	H_s (mm)	SG
Operating		0,08	780,61	1
Test horizontal		0,09	960,52	1
Dimensions				
Inner Diameter		202,72 mm		
Nominal Thickness		25 mm		
Weld Bevel Depth (a)		8,18 mm		
Weld Bevel Depth (b)		9 mm		
Outer Surface to Edge of Weld (t_p)		9,5 mm		
Corrosion	Inner	0 mm		
	Outer	0 mm		
Weight and Capacity				
		Weight (kg)	Capacity (liters)	
New		7,38	0	
Corroded		7,38	0	
Radiography				
Category A joints		Seamless No RT		

Results Summary	
Governing condition	internal pressure
Minimum thickness per UG-16	1,5 mm + 0 mm = 1,5 mm
Design thickness due to internal pressure (t)	14.39 mm
Maximum allowable working pressure (MAWP)	63.52 bar
Maximum allowable pressure (MAP)	63.6 bar
Rated MDMT	-105°C

UCS-66 Material Toughness Requirements	
Stress ratio per UCS-66(b)(1)(b) = $21,08 / 63,6 =$	0,3314
Stress ratio $\leq 0,35$, MDMT per UCS-66(b)(3) =	-105°C
Material is exempt from impact testing at the Design MDMT of -29°C.	

Figure UW-13.2 Weld Sizing					
$a + b \geq 2 \cdot t_s + C_{i,shell} + C_{o,shell}$					
$t_p \geq \min[t_s , 6] + C_o$					
Results					
$a + b =$	17,18 mm	\geq	$2 \cdot 8,18 + 0 + 0 =$	16,36 mm	OK
$t_p =$	9,5 mm	\geq	$\min[8,18 , 6] + 0 =$	6 mm	OK

UG-34(d) Dimensional Checks

$$t_s (8,18 \text{ mm}) \geq 1,25 \cdot t_r (1,25 \cdot 1,83 = 2,29 \text{ mm}) \quad \text{OK}$$

Factor C from Figure UG-34 Sketch (h)

$$\text{Factor C} = 0,33$$

Design thickness, (at 120 °C) UG-34(c)(2)

$$\begin{aligned} t &= d \cdot \text{Sqr}(C \cdot P \cdot 1,02 / (S \cdot E)) + \text{Corrosion} \\ &= 202,72 \cdot \text{Sqr}(0,33 \cdot 21,08 \cdot 1,02 / (1.407,208 \cdot 1)) + 0 \\ &= \underline{14,39} \text{ mm} \end{aligned}$$

Maximum allowable working pressure, (at 120 °C)

$$\begin{aligned} \text{MAWP} &= (S \cdot E / C) \cdot (t / d)^2 - P_s \\ &= (1.407,208 / 1,02 \cdot 1 / 0,33) \cdot (25 / 202,72)^2 - 0,08 \\ &= \underline{63,52} \text{ bar} \end{aligned}$$

Maximum allowable pressure, (At 21,11 °C)

$$\begin{aligned} \text{MAP} &= (S \cdot E / C) \cdot (t / d)^2 \\ &= (1.407,208 / 1,02 \cdot 1 / 0,33) \cdot (25 / 202,72)^2 \\ &= \underline{63,6} \text{ bar} \end{aligned}$$

Saddle #1

ASME Section VIII Division 1, 2019 Edition Metric		
Saddle Material	SA-516-70	
Saddle Construction	Web at edge of rib	
Welded to Vessel	Yes	
Saddle Allowable Stress, S_s	1.163 kg _f /cm ²	
Saddle Yield Stress, S_y	2.284 kg _f /cm ²	
Foundation Allowable Stress	117 kg _f /cm ²	
Design Pressure	Left Saddle	Right Saddle
Operating	21,09 bar	
Test	23,21 bar	
Dimensions		
Right saddle distance to datum	2.718 mm	
Tangent To Tangent Length, L	3.581,2 mm	
Saddle separation, L_s	2.235 mm	
Vessel Radius, R	457,2 mm	
Tangent Distance Left, A_l	521 mm	
Tangent Distance Right, A_r	825,2 mm	
Saddle Height, H_s	914 mm	
Saddle Contact Angle, θ	120°	
Web Plate Thickness, t_s	12,5 mm	
Base Plate Length, E	1.676 mm	
Base Plate Width, F	244 mm	
Base Plate Thickness, t_b	12,5 mm	
Number of Stiffening Ribs, n	2	
Largest Stiffening Rib Spacing, d_l	825,5 mm	
Stiffening Rib Thickness, t_w	12,5 mm	
Saddle Width, b	216 mm	
Reinforcing Plate		
Thickness, t_p	12,5 mm	
Width, W_p	266 mm	
Contact Angle, θ_w	128°	
Bolting		
Material		
Bolt Allowable Shear	1.055 kg _f /cm ²	
Description	M20 x 2.5	
Corrosion on root	0 mm	
Anchor Bolts per Saddle	2	
Base coefficient of friction, μ	0,45	

Hole Diameter	26 mm	
Slotted Hole in Which Saddle	Left Saddle	
Slotted Hole Length	6 mm	
Weight		
	Operating, Corroded	Hydrotest
Weight on Left Saddle	3.625,11 kg	3.632,82 kg
Weight on Right Saddle	4.896,98 kg	4.896,98 kg
Weight of Saddle Pair	322,05 kg	

Notes	
(1) Saddle calculations are based on the method presented in "Stresses in Large Cylindrical Pressure Vessels on Two Saddle Supports" by L.P. Zick.	

Stress Summary										
Load	Condition	Saddle	Bending + pressure between saddles (kgf/cm ²)				Bending + pressure at the saddle (kgf/cm ²)			
			S ₁ (+)	allow (+)	S ₁ (-)	allow (-)	S ₂ (+)	allow (+)	S ₂ (-)	allow (-)
Weight	Operating	Right Saddle	397.176	1.407,208	14.66	1.160,381	493.018	1.407,208	110.502	1.160,381
		Left Saddle					428,221	1.407,208	45,705	1.160,381
	Test	Right Saddle	435,618	2.404,491	14,691	1.160,381	531,529	2.404,491	110,602	1.160,381
		Left Saddle					466,673	2.404,491	45,746	1.160,381

Stress Summary										
Load	Condition	Saddle	Tangential shear (kgf/cm ²)		Circumferential stress (kgf/cm ²)		Stress over saddle (kgf/cm ²)		Splitting (kgf/cm ²)	
			S ₃	allow	S ₄ (horns)	allow (+/-)	S ₅	allow	S ₆	allow
Weight	Operating	Right Saddle	57.121	1.125,767	-279.851	2.110,813	83.069	1.142,1	19.054	775
		Left Saddle	44,543	1.125,767	-207,166	2.110,813	61,494	1.142,1	14,105	775
	Test	Right Saddle	57,081	1.923,593	-279,851	2.404,491	83,069	2.055,78	19,054	2.055,78
		Left Saddle	44,676	1.923,593	-207,607	2.404,491	61,625	2.055,78	14,135	2.055,78

Longitudinal stress between saddles (Weight, Operating, left saddle loading and geometry govern)

$$S_1 = \pm 3 \cdot K_1 \cdot Q \cdot (L / 12) / (\pi \cdot R^2 \cdot t)$$

$$= 300 \cdot 0,3607 \cdot 3.625,11 \cdot (3.581,2 / 12) / (\pi \cdot 450,95^2 \cdot 12,5)$$

$$= 14,66 \text{ kgf/cm}^2$$

$$S_p = P \cdot R / (2 \cdot t)$$

$$= 21,5 \cdot 444,7 / (2 \cdot 12,5)$$

$$= 382,516 \text{ kgf/cm}^2$$

Maximum tensile stress $S_{1t} = S_1 + S_p = \text{397.176 kgf/cm}^2$

Maximum compressive stress (shut down) $S_{1c} = S_1 = \text{14.66 kgf/cm}^2$

Tensile stress is acceptable ($\leq S \cdot E = 1.407,208 \text{ kgf/cm}^2$)

Compressive stress is acceptable ($\leq S_c = 1.160,381 \text{ kgf/cm}^2$)

Longitudinal stress at the right saddle (Weight, Operating)

$$L_e = 2 * (\text{Left head depth}) / 3 + L + 2 * (\text{Right head depth}) / 3$$

$$= 2 * 232,35 / 3 + 3.581,2 + 2 * 232,35 / 3$$

$$= 3.891 \text{ mm}$$

$$w = W_t / L_e = 8.522,09 * 10 / 3.891 = 21,9 \text{ kgf/cm}$$

Bending moment at the right saddle:

$$M_q = w * (2 * H * A_r / 3 + A_r^2 / 2 - (R^2 - H^2) / 4)$$

$$= 21,9 / 10000 * (2 * 232,35 * 825,2 / 3 + 825,2^2 / 2 - (457,2^2 - 232,35^2) / 4)$$

$$= 940,8 \text{ kgf-m}$$

$$S_2 = \pm M_q * K_1' / (\pi * R^2 * t)$$

$$= 940,8 * 1e5 * 9,3799 / (\pi * 450,95^2 * 12,5)$$

$$= 110,502 \text{ kgf/cm}^2$$

$$S_p = P * R / (2 * t)$$

$$= 21,5 * 444,7 / (2 * 12,5)$$

$$= 382,516 \text{ kgf/cm}^2$$

$$\text{Maximum tensile stress } S_{2t} = S_2 + S_p = 493,018 \text{ kgf/cm}^2$$

$$\text{Maximum compressive stress (shut down) } S_{2c} = S_2 = 110,502 \text{ kgf/cm}^2$$

Tensile stress is acceptable ($\leq S = 1.407,208 \text{ kgf/cm}^2$)

Compressive stress is acceptable ($\leq S_c = 1.160,381 \text{ kgf/cm}^2$)

Tangential shear stress in the shell (right saddle, Weight, Operating)

$$Q_{\text{shear}} = Q - w * (a + 2 * H / 3)$$

$$= 4.896,98 - 2,19 * (825,2 + 2 * 232,35 / 3)$$

$$= 2.750,36 \text{ kgf}$$

$$S_3 = K_{2,2} * Q_{\text{shear}} / (R * t)$$

$$= K_{2,2} * 100 * 2.750,36 / (450,95 * 12,5)$$

$$= 57,121 \text{ kgf/cm}^2$$

Tangential shear stress is acceptable ($\leq 0,8 * S = 1.125,767 \text{ kgf/cm}^2$)

Circumferential stress at the right saddle horns (Weight, Operating)

$$S_4 = -Q / (4 * t * (b + 1,56 * \text{Sqr}(R_o * t))) - 12 * K_3 * Q * R / (L * t^2)$$

$$= -100 * 4.896,98 / (4 * 12,5 * (216 + 1,56 * \text{Sqr}(457,2 * 12,5))) - 12 * 0,0529 * 100 * 4.896,98 * 450,95 / (3.581,2 * 12,5^2)$$

$$= -279,851 \text{ kgf/cm}^2$$

Circumferential stress at saddle horns is acceptable ($\leq 1,5 * S_a = 2.110,813 \text{ kgf/cm}^2$)

Ring compression in shell over right saddle (Weight, Operating)

$$S_5 = K_5 * Q / ((t + t_p) * (t_s + 1,56 * \text{Sqr}(R_o * t_c)))$$

$$= 100 * 0,7603 * 4.896,98 / ((12,5 + 12,5) * (12,5 + 1,56 * \text{Sqr}(457,2 * 25)))$$

$$= 83,069 \text{ kgf/cm}^2$$

Ring compression in shell is acceptable ($\leq 0,5 * S_y = 1.142,1 \text{ kgf/cm}^2$)

Saddle splitting load (right, Weight, Operating)

Area resisting splitting force = Web area + wear plate area

$$A_e = H_{\text{eff}} * t_s + t_p * W_p$$

$$= 15,24 * 1,25 + 1,25 * 26,6$$

$$= 52,3 \text{ cm}^2$$

$$S_6 = K_8 * Q / A_e$$

$$= 100 * 0,2035 * 4.896,98 / 5.230$$

$$= 19,054 \text{ kgf/cm}^2$$

Stress in saddle is acceptable ($\leq (2/3) \cdot S_s = 775 \text{ kg}_f/\text{cm}^2$)

Shear stress in anchor bolting, one end slotted

Maximum seismic or wind base shear = 0 kg_f

Thermal expansion base shear = $W \cdot \mu = 3.786,14 \cdot 0,45 = 1.703,76 \text{ kg}_f$

Corroded root area for a M20 x 2.5 bolt = $2,3484 \text{ cm}^2$ (2 per saddle)

Bolt shear stress = $1.703,76 / (2,3484 \cdot 1 \cdot 2) = 362,752 \text{ kg}_f/\text{cm}^2$

Anchor bolt stress is acceptable ($\leq 1.054,604 \text{ kg}_f/\text{cm}^2$)

Shear stress in anchor bolting, transverse

Maximum seismic or wind base shear = 0 kg_f

Corroded root area for a M20 x 2.5 bolt = $2,3484 \text{ cm}^2$ (2 per saddle)

Bolt shear stress = $0 / (2,3484 \cdot 2 \cdot 2) = 0 \text{ kg}_f/\text{cm}^2$

Anchor bolt stress is acceptable ($\leq 1.054,604 \text{ kg}_f/\text{cm}^2$)

Web plate buckling check (Escoe pg 251)

Allowable compressive stress S_c is the lesser of 1.162,5 or 540,841 kg_f/cm^2 : (540,841)

$$\begin{aligned} S_c &= K_1 \cdot \pi^2 \cdot E / (12 \cdot (1 - 0,3^2) \cdot (d_i / t_s)^2) \\ &= 1,28 \cdot \pi^2 \cdot 20,39 \text{E}+05 / (12 \cdot (1 - 0,3^2) \cdot (825,5 / 12,5)^2) \\ &= 540,841 \text{ kg}_f/\text{cm}^2 \end{aligned}$$

Allowable compressive load on the saddle

$$\begin{aligned} b_e &= d_i \cdot t_s / (d_i \cdot t_s + 2 \cdot t_w \cdot (b - 25,4)) \cdot 25,4 \\ &= 825,5 \cdot 12,5 / (825,5 \cdot 12,5 + 2 \cdot 12,5 \cdot (216 - 25,4)) \cdot 25,4 \\ &= 17,38 \end{aligned}$$

$$\begin{aligned} F_b &= n \cdot (A_s + 2 \cdot b_e \cdot t_s) \cdot S_c \\ &= 2 \cdot (2.543,75 + 2 \cdot 17,38 \cdot 12,5) \cdot 540,841 \\ &= 32.214,11 \text{ kg}_f \end{aligned}$$

Saddle loading of 5.058,01 kg_f is $\leq F_b$; satisfactory.

Primary bending + axial stress in the saddle due to end loads (assumes one saddle slotted)

$$\begin{aligned} \sigma_b &= V \cdot (H_s - x_o) \cdot y / I + Q / A \\ &= 0 \cdot (914 - 378,1) \cdot 145,3 / (100 \cdot 4.152,95) + 100 \cdot 4.896,98 / 14.986,17 \\ &= 32,677 \text{ kg}_f/\text{cm}^2 \end{aligned}$$

The primary bending + axial stress in the saddle $\leq S_s = 1.162,5 \text{ kg}_f/\text{cm}^2$; satisfactory.

Secondary bending + axial stress in the saddle due to end loads (includes thermal expansion, assumes one saddle slotted)

$$\begin{aligned} \sigma_b &= V \cdot (H_s - x_o) \cdot y / I + Q / A \\ &= 1.703,76 \cdot (914 - 378,1) \cdot 145,3 / (100 \cdot 4.152,95) + 100 \cdot 3.625,11 / 14.986,17 \\ &= 343,634 \text{ kg}_f/\text{cm}^2 \end{aligned}$$

The secondary bending + axial stress in the saddle $\leq 2 \cdot S_y = 4.568,4 \text{ kg}_f/\text{cm}^2$; satisfactory.

Saddle base plate thickness check (Roark sixth edition, Table 26, case 7a)

where $a = 825,5$, $b = 231,5$ mm

$$\begin{aligned} t_b &= (\beta_1 \cdot q \cdot b^2 / (1,5 \cdot S_a))^{0,5} \\ &= (3 \cdot 1,237 \cdot 231,5^2 / (1,5 \cdot 1.162,5))^{0,5} \\ &= 10,68 \text{ mm} \end{aligned}$$

The base plate thickness of 12,5 mm is adequate.

Foundation bearing check

$$\begin{aligned} S_f &= Q_{\max} / (F \cdot E) \\ &= 5.058,01 / (244 \cdot 1.676) \\ &= 1,237 \text{ kg}_f/\text{cm}^2 \end{aligned}$$

Concrete bearing stress $\leq 116,569 \text{ kg}_f/\text{cm}^2$; satisfactory.

Slotted hole length (Process Industry Practices VEFV1100)

$$\begin{aligned} \Delta_t &= \max[\text{abs}(T_{\text{amb}} - T_s), \text{abs}(T_{\text{amb}} - \text{MDMT})] \\ &= \max[\text{abs}(21 - 120), \text{abs}(21 - -29)] \\ &= 99^\circ\text{C} \end{aligned}$$

$$\begin{aligned} S_L &= 2 \cdot L_s \cdot \alpha \cdot \Delta_t \\ &= 2 \cdot 2.235 \cdot 1,226\text{E-}05 \cdot 99 \\ &= 5,43 \text{ mm} \end{aligned}$$

Actual slot length is greater than or equal to the minimum (6 mm \geq 5,43 mm); satisfactory.

Sight Glass (U)

ASME Section VIII Division 1, 2019 Edition Metric

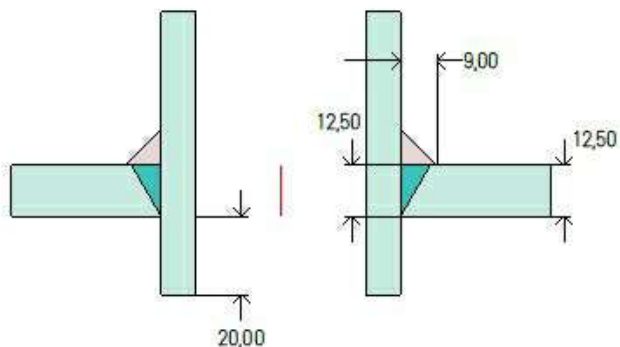

Note: round inside edges per UG-76(c)

Location and Orientation

Located on	Cylinder #1
Orientation	90°
Nozzle center line offset to datum line	152,4 mm
End of nozzle to shell center	406 mm
Offset from center, Lo	355,6 mm
Passes through a Category A joint	No

Nozzle

Description	NPS 2 Sch 160 DN 50
Access opening	No
Material specification	SA-106 B Smls Pipe (II-D Metric p. 16, In. 10)
Inside diameter, new	42,85 mm
Pipe nominal wall thickness	8,74 mm
Pipe minimum wall thickness ¹	7,65 mm
Corrosion allowance	0 mm
Opening chord length	70,78 mm
Projection available outside vessel, Lpr	84,87 mm
Internal projection, h _{new}	20 mm
Local vessel minimum thickness	12,5 mm
Liquid static head included	0,08 bar
Longitudinal joint efficiency	1

Welds

Inner fillet, Leg ₄₁	9 mm
Lower fillet, Leg ₄₃	0 mm
Nozzle to vessel groove weld	12,5 mm

¹Pipe minimum thickness = nominal thickness times pipe tolerance factor of 0,875.

UCS-66 Material Toughness Requirements Nozzle	
$t_r = 21,08 \cdot 21,42 / (1.180 \cdot 1 - 0,6 \cdot 21,08) =$	0,39 mm
Stress ratio = $t_r \cdot E^* / (t_n - c) = 0,39 \cdot 1 / (7,65 - 0) =$	0,0506
Stress ratio $\leq 0,35$, MDMT per UCS-66(b)(3) =	-105°C
Material is exempt from impact testing at the Design MDMT of -29°C.	

Reinforcement Calculations for Internal Pressure

UG-37 Area Calculation Summary (cm ²)							UG-45 Summary (mm)	
For P = 21,08 bar @ 120 °C							The nozzle passes UG-45	
A required	A available	A ₁	A ₂	A ₃	A ₅	A welds	t _{req}	t _{min}
This nozzle is exempt from area calculations per UG-36(c)(3)(a)							3,42	7,65

UG-41 Weld Failure Path Analysis Summary
The nozzle is exempt from weld strength calculations per UW-15(b)(2)

UW-16 Weld Sizing Summary			
Weld description	Required weld throat size (mm)	Actual weld throat size (mm)	Status
Nozzle to shell fillet (Leg ₄₁)	6	6,3	weld size is adequate

Calculations for internal pressure 21,08 bar @ 120 °C

Parallel Limit of reinforcement per UG-40

$$\begin{aligned}
 L_R &= \text{MAX}(d, R_n + (t_n - C_n) + (t - C)) \\
 &= \text{MAX}(70,78, 35,39 + (8,74 - 0) + (12,5 - 0)) \\
 &= 70,78 \text{ mm}
 \end{aligned}$$

Outer Normal Limit of reinforcement per UG-40

$$\begin{aligned}
 L_H &= \text{MIN}(2,5*(t - C), 2,5*(t_n - C_n) + t_e) \\
 &= \text{MIN}(2,5*(12,5 - 0), 2,5*(8,74 - 0) + 0) \\
 &= 21,84 \text{ mm}
 \end{aligned}$$

Inner Normal Limit of reinforcement per UG-40

$$\begin{aligned}
 L_I &= \text{MIN}(h, 2,5*(t - C), 2,5*(t_i - C_n - C)) \\
 &= \text{MIN}(20, 2,5*(12,5 - 0), 2,5*(8,74 - 0 - 0)) \\
 &= 20 \text{ mm}
 \end{aligned}$$

Nozzle required thickness per UG-27(c)(1)

$$\begin{aligned}
 t_{rn} &= P * R_n / (S_n * E - 0,6 * P) \\
 &= 21,0797 * 21,42 / (1,180 * 1 - 0,6 * 21,0797) \\
 &= 0,39 \text{ mm}
 \end{aligned}$$

Required thickness t_r from UG-37(a)

$$\begin{aligned}
 t_r &= P * R_o / (S * E + 0,4 * P) \\
 &= 21,0797 * 457,2 / (1,380 * 1 + 0,4 * 21,0797) \\
 &= 6,94 \text{ mm}
 \end{aligned}$$

This opening does not require reinforcement per UG-36(c)(3)(a)

UW-16(c) Weld Check

Fillet weld: t_{min} = lesser of 19 mm or t_n or t = 8,74 mm

t_{c(min)} = lesser of 6 mm or 0,7*t_{min} = 6 mm

t_{c(actual)} = 0,7*Leg = 0,7*9 = 6,3 mm

The fillet weld size is satisfactory.

Weld strength calculations are not required for this detail which conforms to Fig. UW-16.1, sketch (c-e).

UG-45 Nozzle Neck Thickness Check

$$\begin{aligned}t_{a \text{ UG-27}} &= P \cdot R_n / (S_n \cdot E - 0,6 \cdot P) + \text{Corrosion} \\ &= 21,0797 \cdot 21,42 / (1,180 \cdot 1 - 0,6 \cdot 21,0797) + 0 \\ &= 0,39 \text{ mm}\end{aligned}$$

$$\begin{aligned}t_a &= \max[t_{a \text{ UG-27}}, t_{a \text{ UG-22}}] \\ &= \max[0,39, 0] \\ &= 0,39 \text{ mm}\end{aligned}$$

$$\begin{aligned}t_{b1} &= P \cdot R_o / (S \cdot E + 0,4 \cdot P) + \text{Corrosion} \\ &= 21,0797 \cdot 457,2 / (1,380 \cdot 1 + 0,4 \cdot 21,0797) + 0 \\ &= 6,94 \text{ mm}\end{aligned}$$

$$\begin{aligned}t_{b1} &= \max[t_{b1}, t_{b \text{ UG16}}] \\ &= \max[6,94, 1,5] \\ &= 6,94 \text{ mm}\end{aligned}$$

$$\begin{aligned}t_b &= \min[t_{b3}, t_{b1}] \\ &= \min[3,42, 6,94] \\ &= 3,42 \text{ mm}\end{aligned}$$

$$\begin{aligned}t_{\text{UG-45}} &= \max[t_a, t_b] \\ &= \max[0,39, 3,42] \\ &= 3,42 \text{ mm}\end{aligned}$$

Available nozzle wall thickness new, $t_n = 0,875 \cdot 8,74 = 7,65 \text{ mm}$

The nozzle neck thickness is adequate.

Reinforcement check in the plane parallel to the longitudinal axis

Reinforcement Calculations for Internal Pressure

UG-37 Area Calculation Summary (cm ²)							UG-45 Summary (mm)	
For P = 21,08 bar @ 120 °C							The nozzle passes UG-45	
A required	A available	A ₁	A ₂	A ₃	A ₅	A welds	t _{req}	t _{min}
This nozzle is exempt from area calculations per UG-36(c)(3)(a)							3,42	7,65

UG-41 Weld Failure Path Analysis Summary
The nozzle is exempt from weld strength calculations per UW-15(b)(2)

UW-16 Weld Sizing Summary			
Weld description	Required weld throat size (mm)	Actual weld throat size (mm)	Status
Nozzle to shell fillet (Leg ₄₁)	6	6,3	weld size is adequate

Parallel Limit of reinforcement per UG-40

$$\begin{aligned}
 L_R &= \text{MAX}(d, R_n + (t_n - C_n) + (t - C)) \\
 &= \text{MAX}(42,85, 21,42 + (8,74 - 0) + (12,5 - 0)) \\
 &= 42,85 \text{ mm}
 \end{aligned}$$

Outer Normal Limit of reinforcement per UG-40

$$\begin{aligned}
 L_H &= \text{MIN}(2,5*(t - C), 2,5*(t_n - C_n) + t_e) \\
 &= \text{MIN}(2,5*(12,5 - 0), 2,5*(8,74 - 0) + 0) \\
 &= 21,84 \text{ mm}
 \end{aligned}$$

Inner Normal Limit of reinforcement per UG-40

$$\begin{aligned}
 L_I &= \text{MIN}(h, 2,5*(t - C), 2,5*(t_i - C_n - C)) \\
 &= \text{MIN}(20, 2,5*(12,5 - 0), 2,5*(8,74 - 0 - 0)) \\
 &= 20 \text{ mm}
 \end{aligned}$$

Nozzle required thickness per UG-27(c)(1)

$$\begin{aligned}
 t_{rn} &= P * R_n / (S_n * E - 0,6 * P) \\
 &= 21,0797 * 21,42 / (1.180 * 1 - 0,6 * 21,0797) \\
 &= 0,39 \text{ mm}
 \end{aligned}$$

Required thickness t_r from UG-37(a)

$$\begin{aligned}
 t_r &= P * R_o / (S * E + 0,4 * P) \\
 &= 21,0797 * 457,2 / (1.380 * 1 + 0,4 * 21,0797) \\
 &= 6,94 \text{ mm}
 \end{aligned}$$

This opening does not require reinforcement per UG-36(c)(3)(a)

UG-45 Nozzle Neck Thickness Check

$$\begin{aligned}
 t_{a \text{ UG-27}} &= P * R_n / (S_n * E - 0,6 * P) + \text{Corrosion} \\
 &= 21,0797 * 21,42 / (1.180 * 1 - 0,6 * 21,0797) + 0 \\
 &= 0,39 \text{ mm}
 \end{aligned}$$

$$\begin{aligned}
 t_a &= \text{max}[t_{a \text{ UG-27}}, t_{a \text{ UG-22}}] \\
 &= \text{max}[0,39, 0] \\
 &= 0,39 \text{ mm}
 \end{aligned}$$

$$\begin{aligned}
 t_{b1} &= P \cdot R_o / (S \cdot E + 0,4 \cdot P) + \text{Corrosion} \\
 &= 21,0797 \cdot 457,2 / (1.380 \cdot 1 + 0,4 \cdot 21,0797) + 0 \\
 &= 6,94 \text{ mm}
 \end{aligned}$$

$$\begin{aligned}
 t_{b1} &= \max[t_{b1} , t_{b \text{UG16}}] \\
 &= \max[6,94 , 1,5] \\
 &= 6,94 \text{ mm}
 \end{aligned}$$

$$\begin{aligned}
 t_b &= \min[t_{b3} , t_{b1}] \\
 &= \min[3,42 , 6,94] \\
 &= 3,42 \text{ mm}
 \end{aligned}$$

$$\begin{aligned}
 t_{\text{UG-45}} &= \max[t_a , t_b] \\
 &= \max[0,39 , 3,42] \\
 &= \underline{3,42} \text{ mm}
 \end{aligned}$$

Available nozzle wall thickness new, $t_n = 0,875 \cdot 8,74 = 7,65 \text{ mm}$

The nozzle neck thickness is adequate.

Compressor #1

Geometry	
Height (radial)	200 mm
Width (circumferential)	813 mm
Length	25 mm
Fillet Weld Size:	6 mm
Located On	Cylinder #1 (667 mm from left end)
Location Angle	0,00°

Applied Loads	
Radial load, P_r	600 kg _f
Circumferential moment, M_c	0 kg _f -m
Circumferential shear, V_c	0 kg _f
Longitudinal moment, M_L	0 kg _f -m
Longitudinal shear, V_L	0 kg _f
Torsion moment, M_t	0 kg _f -m
Internal pressure, P	21 bar
Mean shell radius, R_m	450,95 mm
Design factor	3

Maximum stresses due to the applied loads at the lug edge (includes pressure)

$$\gamma = R_m / T = 450,95 / 12,5 = 36,076$$

$$C_1 = 74, C_2 = 18,5 \text{ mm}$$

Note: Actual lug $C_1 / C_2 > 4$, $C_1 / C_2 = 4$ used as this is the maximum ratio covered by WRC 107.

$$\text{Local circumferential pressure stress} = P \cdot R_i / T = 761,846 \text{ kg}_f/\text{cm}^2$$

$$\text{Local longitudinal pressure stress} = P \cdot R_i / (2 \cdot T) = 380,923 \text{ kg}_f/\text{cm}^2$$

$$\text{Maximum combined stress } (P_L + P_b + Q) = 926,22 \text{ kg}_f/\text{cm}^2$$

$$\text{Allowable combined stress } (P_L + P_b + Q) = \pm 3 \cdot S = \pm 4.221,63 \text{ kg}_f/\text{cm}^2$$

The maximum combined stress $(P_L + P_b + Q)$ is within allowable limits.

$$\text{Maximum local primary membrane stress } (P_L) = 699,48 \text{ kg}_f/\text{cm}^2$$

$$\text{Allowable local primary membrane stress } (P_L) = \pm 1,5 \cdot S = \pm 2.110,81 \text{ kg}_f/\text{cm}^2$$

The maximum local primary membrane stress (P_L) is within allowable limits.

Stresses at the lug edge per WRC Bulletin 107										
Figure	value	β	A_u	A_l	B_u	B_l	C_u	C_l	D_u	D_l
3C*	6,1637	0,0747	0	0	0	0	-65,596	-65,596	-65,596	-65,596
4C*	5,862	0,1378	-62,362	-62,362	-62,362	-62,362	0	0	0	0
1C	0,0998	0,1444	0	0	0	0	-229,974	229,974	-229,974	229,974
2C-1	0,0644	0,1444	-148,348	148,348	-148,348	148,348	0	0	0	0
3A*	1,1269	0,1034	0	0	0	0	0	0	0	0
1A	0,0883	0,1495	0	0	0	0	0	0	0	0
3B*	2,61	0,0651	0	0	0	0	0	0	0	0
1B-1	0,0455	0,1113	0	0	0	0	0	0	0	0
Pressure stress*			761,846	761,846	761,846	761,846	761,846	761,846	761,846	761,846
Total circumferential stress			551,136	847,832	551,136	847,832	466,276	926,224	466,276	926,224
Primary membrane circumferential stress*			699,484	699,484	699,484	699,484	696,25	696,25	696,25	696,25
3C*	4,7152	0,1378	-50,199	-50,199	-50,199	-50,199	0	0	0	0
4C*	6,6169	0,0747	0	0	0	0	-70,448	-70,448	-70,448	-70,448
1C-1	0,1378	0,0985	-317,506	317,506	-317,506	317,506	0	0	0	0
2C	0,0974	0,0985	0	0	0	0	-224,42	224,42	-224,42	224,42
4A*	1,5814	0,1034	0	0	0	0	0	0	0	0
2A	0,053	0,111	0	0	0	0	0	0	0	0
4B*	0,6828	0,0651	0	0	0	0	0	0	0	0
2B-1	0,086	0,0776	0	0	0	0	0	0	0	0
Pressure stress*			380,923	380,923	380,923	380,923	380,923	380,923	380,923	380,923
Total longitudinal stress			13,218	648,23	13,218	648,23	86,056	534,895	86,056	534,895
Primary membrane longitudinal stress*			330,724	330,724	330,724	330,724	310,476	310,476	310,476	310,476
Shear from M_t			0	0	0	0	0	0	0	0
Circ shear from V_c			0	0	0	0	0	0	0	0
Long shear from V_L			0	0	0	0	0	0	0	0
Total Shear stress			0	0	0	0	0	0	0	0
Combined stress (P_L+P_b+Q)			551,136	847,832	551,136	847,832	466,276	926,224	466,276	926,224
* denotes primary stress.										

Compressor#2

Geometry	
Height (radial)	200 mm
Width (circumferential)	813 mm
Length	25 mm
Fillet Weld Size:	6 mm
Located On	Cylinder #1 (1.111 mm from left end)
Location Angle	0,00°

Applied Loads	
Radial load, P_r	600 kg _f
Circumferential moment, M_c	0 kg _f -m
Circumferential shear, V_c	0 kg _f
Longitudinal moment, M_L	0 kg _f -m
Longitudinal shear, V_L	0 kg _f
Torsion moment, M_t	0 kg _f -m
Internal pressure, P	21 bar
Mean shell radius, R_m	450,95 mm
Design factor	3

Maximum stresses due to the applied loads at the lug edge (includes pressure)

$$\gamma = R_m / T = 450,95 / 12,5 = 36,076$$

$$C_1 = 74, C_2 = 18,5 \text{ mm}$$

Note: Actual lug $C_1 / C_2 > 4$, $C_1 / C_2 = 4$ used as this is the maximum ratio covered by WRC 107.

$$\text{Local circumferential pressure stress} = P \cdot R_i / T = 761,846 \text{ kg}_f/\text{cm}^2$$

$$\text{Local longitudinal pressure stress} = P \cdot R_i / (2 \cdot T) = 380,923 \text{ kg}_f/\text{cm}^2$$

$$\text{Maximum combined stress } (P_L + P_b + Q) = 926,22 \text{ kg}_f/\text{cm}^2$$

$$\text{Allowable combined stress } (P_L + P_b + Q) = \pm 3 \cdot S = \pm 4.221,63 \text{ kg}_f/\text{cm}^2$$

The maximum combined stress $(P_L + P_b + Q)$ is within allowable limits.

$$\text{Maximum local primary membrane stress } (P_L) = 699,48 \text{ kg}_f/\text{cm}^2$$

$$\text{Allowable local primary membrane stress } (P_L) = \pm 1,5 \cdot S = \pm 2.110,81 \text{ kg}_f/\text{cm}^2$$

The maximum local primary membrane stress (P_L) is within allowable limits.

Stresses at the lug edge per WRC Bulletin 107										
Figure	value	β	A_u	A_l	B_u	B_l	C_u	C_l	D_u	D_l
3C*	6,1637	0,0747	0	0	0	0	-65,596	-65,596	-65,596	-65,596
4C*	5,862	0,1378	-62,362	-62,362	-62,362	-62,362	0	0	0	0
1C	0,0998	0,1444	0	0	0	0	-229,974	229,974	-229,974	229,974
2C-1	0,0644	0,1444	-148,348	148,348	-148,348	148,348	0	0	0	0
3A*	1,1269	0,1034	0	0	0	0	0	0	0	0
1A	0,0883	0,1495	0	0	0	0	0	0	0	0
3B*	2,61	0,0651	0	0	0	0	0	0	0	0
1B-1	0,0455	0,1113	0	0	0	0	0	0	0	0
Pressure stress*			761,846	761,846	761,846	761,846	761,846	761,846	761,846	761,846
Total circumferential stress			551,136	847,832	551,136	847,832	466,276	926,224	466,276	926,224
Primary membrane circumferential stress*			699,484	699,484	699,484	699,484	696,25	696,25	696,25	696,25
3C*	4,7152	0,1378	-50,199	-50,199	-50,199	-50,199	0	0	0	0
4C*	6,6169	0,0747	0	0	0	0	-70,448	-70,448	-70,448	-70,448
1C-1	0,1378	0,0985	-317,506	317,506	-317,506	317,506	0	0	0	0
2C	0,0974	0,0985	0	0	0	0	-224,42	224,42	-224,42	224,42
4A*	1,5814	0,1034	0	0	0	0	0	0	0	0
2A	0,053	0,111	0	0	0	0	0	0	0	0
4B*	0,6828	0,0651	0	0	0	0	0	0	0	0
2B-1	0,086	0,0776	0	0	0	0	0	0	0	0
Pressure stress*			380,923	380,923	380,923	380,923	380,923	380,923	380,923	380,923
Total longitudinal stress			13,218	648,23	13,218	648,23	86,056	534,895	86,056	534,895
Primary membrane longitudinal stress*			330,724	330,724	330,724	330,724	310,476	310,476	310,476	310,476
Shear from M_t			0	0	0	0	0	0	0	0
Circ shear from V_c			0	0	0	0	0	0	0	0
Long shear from V_L			0	0	0	0	0	0	0	0
Total Shear stress			0	0	0	0	0	0	0	0
Combined stress (P_L+P_b+Q)			551,136	847,832	551,136	847,832	466,276	926,224	466,276	926,224

* denotes primary stress.

Oil Filter Bracket #1

Geometry	
Height (radial)	511 mm
Width (circumferential)	127 mm
Length	4,76 mm
Fillet Weld Size:	5 mm
Located On	Cylinder #1 (148 mm from left end)
Location Angle	270,00°

Applied Loads	
Radial load, P_r	0 kg _f
Circumferential moment, M_c	18 kg _f -m
Circumferential shear, V_c	52 kg _f
Longitudinal moment, M_L	0 kg _f -m
Longitudinal shear, V_L	0 kg _f
Torsion moment, M_t	0 kg _f -m
Internal pressure, P	21,04 bar
Mean shell radius, R_m	450,95 mm
Design factor	3

Maximum stresses due to the applied loads at the lug edge (includes pressure)

$$\gamma = R_m / T = 450,95 / 12,5 = 36,076$$

$$C_1 = 29,52, C_2 = 7,38 \text{ mm}$$

Note: Actual lug $C_1 / C_2 > 4$, $C_1 / C_2 = 4$ used as this is the maximum ratio covered by WRC 107.

$$\text{Local circumferential pressure stress} = P \cdot R_i / T = 763,463 \text{ kg}_f/\text{cm}^2$$

$$\text{Local longitudinal pressure stress} = P \cdot R_i / (2 \cdot T) = 381,767 \text{ kg}_f/\text{cm}^2$$

$$\text{Maximum combined stress } (P_L + P_b + Q) = 1.044,06 \text{ kg}_f/\text{cm}^2$$

$$\text{Allowable combined stress } (P_L + P_b + Q) = \pm 3 \cdot S = \pm 4.221,63 \text{ kg}_f/\text{cm}^2$$

The maximum combined stress $(P_L + P_b + Q)$ is within allowable limits.

$$\text{Maximum local primary membrane stress } (P_L) = 774,15 \text{ kg}_f/\text{cm}^2$$

$$\text{Allowable local primary membrane stress } (P_L) = \pm 1,5 \cdot S = \pm 2.110,81 \text{ kg}_f/\text{cm}^2$$

The maximum local primary membrane stress (P_L) is within allowable limits.

Stresses at the lug edge per WRC Bulletin 107										
Figure	value	β	A_u	A_l	B_u	B_l	C_u	C_l	D_u	D_l
3C*	7,1464	0,0298	0	0	0	0	0	0	0	0
4C*	6,8531	0,055	0	0	0	0	0	0	0	0
1C	0,1844	0,0576	0	0	0	0	0	0	0	0
2C-1	0,1459	0,0576	0	0	0	0	0	0	0	0
3A*	0,3694	0,0412	0	0	0	0	-10,687	-10,687	10,687	10,687
1A	0,105	0,0596	0	0	0	0	-269,908	269,908	269,908	-269,908
3B*	0,8346	0,026	0	0	0	0	0	0	0	0
1B-1	0,0602	0,0444	0	0	0	0	0	0	0	0
Pressure stress*			763,463	763,463	763,463	763,463	763,463	763,463	763,463	763,463
Total circumferential stress			763,463	763,463	763,463	763,463	482,868	1.022,685	1.044,058	504,242
Primary membrane circumferential stress*			763,463	763,463	763,463	763,463	752,777	752,777	774,15	774,15
3C*	6,6278	0,055	0	0	0	0	0	0	0	0
4C*	7,1	0,0298	0	0	0	0	0	0	0	0
1C-1	0,2298	0,0393	0	0	0	0	0	0	0	0
2C	0,1811	0,0393	0	0	0	0	0	0	0	0
4A*	0,4927	0,0412	0	0	0	0	-10,054	-10,054	10,054	10,054
2A	0,0628	0,0443	0	0	0	0	-217,319	217,319	217,319	-217,319
4B*	0,2052	0,026	0	0	0	0	0	0	0	0
2B-1	0,1074	0,031	0	0	0	0	0	0	0	0
Pressure stress*			381,767	381,767	381,767	381,767	381,767	381,767	381,767	381,767
Total longitudinal stress			381,767	381,767	381,767	381,767	154,394	589,032	609,139	174,502
Primary membrane longitudinal stress*			381,767	381,767	381,767	381,767	371,713	371,713	391,821	391,821
Shear from M_t			0	0	0	0	0	0	0	0
Circ shear from V_c			3,515	3,515	-3,515	-3,515	0	0	0	0
Long shear from V_L			0	0	0	0	0	0	0	0
Total Shear stress			3,515	3,515	-3,515	-3,515	0	0	0	0
Combined stress (P_L+P_b+Q)			763,463	763,463	763,463	763,463	482,868	1.022,685	1.044,058	504,242

* denotes primary stress.

Oil Filter Bracket #2

Geometry	
Height (radial)	511 mm
Width (circumferential)	127 mm
Length	4,76 mm
Fillet Weld Size:	5 mm
Located On	Cylinder #1 (757 mm from left end)
Location Angle	270,00°

Applied Loads	
Radial load, P_r	0 kg _f
Circumferential moment, M_c	18 kg _f -m
Circumferential shear, V_c	52 kg _f
Longitudinal moment, M_L	0 kg _f -m
Longitudinal shear, V_L	0 kg _f
Torsion moment, M_t	0 kg _f -m
Internal pressure, P	21,04 bar
Mean shell radius, R_m	450,95 mm
Design factor	3

Maximum stresses due to the applied loads at the lug edge (includes pressure)

$$\gamma = R_m / T = 450,95 / 12,5 = 36,076$$

$$C_1 = 29,52, C_2 = 7,38 \text{ mm}$$

Note: Actual lug $C_1 / C_2 > 4$, $C_1 / C_2 = 4$ used as this is the maximum ratio covered by WRC 107.

$$\text{Local circumferential pressure stress} = P \cdot R_i / T = 763,463 \text{ kg}_f/\text{cm}^2$$

$$\text{Local longitudinal pressure stress} = P \cdot R_i / (2 \cdot T) = 381,767 \text{ kg}_f/\text{cm}^2$$

$$\text{Maximum combined stress } (P_L + P_b + Q) = 1.044,06 \text{ kg}_f/\text{cm}^2$$

$$\text{Allowable combined stress } (P_L + P_b + Q) = \pm 3 \cdot S = \pm 4.221,63 \text{ kg}_f/\text{cm}^2$$

The maximum combined stress $(P_L + P_b + Q)$ is within allowable limits.

$$\text{Maximum local primary membrane stress } (P_L) = 774,15 \text{ kg}_f/\text{cm}^2$$

$$\text{Allowable local primary membrane stress } (P_L) = \pm 1,5 \cdot S = \pm 2.110,81 \text{ kg}_f/\text{cm}^2$$

The maximum local primary membrane stress (P_L) is within allowable limits.

Stresses at the lug edge per WRC Bulletin 107										
Figure	value	β	A_u	A_l	B_u	B_l	C_u	C_l	D_u	D_l
3C*	7,1464	0,0298	0	0	0	0	0	0	0	0
4C*	6,8531	0,055	0	0	0	0	0	0	0	0
1C	0,1844	0,0576	0	0	0	0	0	0	0	0
2C-1	0,1459	0,0576	0	0	0	0	0	0	0	0
3A*	0,3694	0,0412	0	0	0	0	-10,687	-10,687	10,687	10,687
1A	0,105	0,0596	0	0	0	0	-269,908	269,908	269,908	-269,908
3B*	0,8346	0,026	0	0	0	0	0	0	0	0
1B-1	0,0602	0,0444	0	0	0	0	0	0	0	0
Pressure stress*			763,463	763,463	763,463	763,463	763,463	763,463	763,463	763,463
Total circumferential stress			763,463	763,463	763,463	763,463	482,868	1.022,685	1.044,058	504,242
Primary membrane circumferential stress*			763,463	763,463	763,463	763,463	752,777	752,777	774,15	774,15
3C*	6,6278	0,055	0	0	0	0	0	0	0	0
4C*	7,1	0,0298	0	0	0	0	0	0	0	0
1C-1	0,2298	0,0393	0	0	0	0	0	0	0	0
2C	0,1811	0,0393	0	0	0	0	0	0	0	0
4A*	0,4927	0,0412	0	0	0	0	-10,054	-10,054	10,054	10,054
2A	0,0628	0,0443	0	0	0	0	-217,319	217,319	217,319	-217,319
4B*	0,2052	0,026	0	0	0	0	0	0	0	0
2B-1	0,1074	0,031	0	0	0	0	0	0	0	0
Pressure stress*			381,767	381,767	381,767	381,767	381,767	381,767	381,767	381,767
Total longitudinal stress			381,767	381,767	381,767	381,767	154,394	589,032	609,139	174,502
Primary membrane longitudinal stress*			381,767	381,767	381,767	381,767	371,713	371,713	391,821	391,821
Shear from M_t			0	0	0	0	0	0	0	0
Circ shear from V_c			3,515	3,515	-3,515	-3,515	0	0	0	0
Long shear from V_L			0	0	0	0	0	0	0	0
Total Shear stress			3,515	3,515	-3,515	-3,515	0	0	0	0
Combined stress (P_L+P_b+Q)			763,463	763,463	763,463	763,463	482,868	1.022,685	1.044,058	504,242

* denotes primary stress.

Motor Support pad #1

Geometry	
Height (radial)	6,3 mm
Width (circumferential)	279 mm
Length	914 mm
Fillet Weld Size:	6 mm
Located On	Cylinder #1 (127 mm from right end)
Location Angle	0,00°

Applied Loads	
Radial load, P_r	650 kg _f
Circumferential moment, M_c	0 kg _f -m
Circumferential shear, V_c	0 kg _f
Longitudinal moment, M_L	0 kg _f -m
Longitudinal shear, V_L	0 kg _f
Torsion moment, M_t	0 kg _f -m
Internal pressure, P	21 bar
Mean shell radius, R_m	450,95 mm
Design factor	3

Maximum stresses due to the applied loads at the lug edge (includes pressure)

$$\gamma = R_m / T = 450,95 / 12,5 = 36,076$$

$$C_1 = 145,5, C_2 = 463 \text{ mm}$$

$$\text{Local circumferential pressure stress} = P \cdot R_i / T = 761,846 \text{ kg}_f/\text{cm}^2$$

$$\text{Local longitudinal pressure stress} = P \cdot R_i / (2 \cdot T) = 380,923 \text{ kg}_f/\text{cm}^2$$

$$\text{Maximum combined stress } (P_L + P_b + Q) = 903,94 \text{ kg}_f/\text{cm}^2$$

$$\text{Allowable combined stress } (P_L + P_b + Q) = \pm 3 \cdot S = \pm 4.221,63 \text{ kg}_f/\text{cm}^2$$

The maximum combined stress ($P_L + P_b + Q$) is within allowable limits.

$$\text{Maximum local primary membrane stress } (P_L) = 750,67 \text{ kg}_f/\text{cm}^2$$

$$\text{Allowable local primary membrane stress } (P_L) = \pm 1,5 \cdot S = \pm 2.110,81 \text{ kg}_f/\text{cm}^2$$

The maximum local primary membrane stress (P_L) is within allowable limits.

Stresses at the lug edge per WRC Bulletin 107										
Figure	value	β	A_u	A_l	B_u	B_l	C_u	C_l	D_u	D_l
3C*	0,9703	0,8282	0	0	0	0	-11,179	-11,179	-11,179	-11,179
4C*	2,447	0,6808	-28,193	-28,193	-28,193	-28,193	0	0	0	0
1C	0,0614	0,5124	0	0	0	0	-153,269	153,269	-153,269	153,269
2C-1	0,007	0,5124	-17,506	17,506	-17,506	17,506	0	0	0	0
3A*	0,9044	0,4746	0	0	0	0	0	0	0	0
1A	0,0622	0,5793	0	0	0	0	0	0	0	0
3B*	1,3939	0,698	0	0	0	0	0	0	0	0
1B-1	0,0089	0,6263	0	0	0	0	0	0	0	0
Pressure stress*			761,846	761,846	761,846	761,846	761,846	761,846	761,846	761,846
Total circumferential stress			716,147	751,16	716,147	751,16	597,398	903,937	597,398	903,937
Primary membrane circumferential stress*			733,653	733,653	733,653	733,653	750,667	750,667	750,667	750,667
3C*	0,9703	0,6808	-11,179	-11,179	-11,179	-11,179	0	0	0	0
4C*	2,447	0,8282	0	0	0	0	-28,193	-28,193	-28,193	-28,193
1C-1	0,0179	0,7071	-44,645	44,645	-44,645	44,645	0	0	0	0
2C	0,03	0,7071	0	0	0	0	-74,877	74,877	-74,877	74,877
4A*	3,481	0,4746	0	0	0	0	0	0	0	0
2A	0,0269	0,7643	0	0	0	0	0	0	0	0
4B*	0,8162	0,698	0	0	0	0	0	0	0	0
2B-1	0,0178	0,8155	0	0	0	0	0	0	0	0
Pressure stress*			380,923	380,923	380,923	380,923	380,923	380,923	380,923	380,923
Total longitudinal stress			325,099	414,389	325,099	414,389	277,853	427,607	277,853	427,607
Primary membrane longitudinal stress*			369,744	369,744	369,744	369,744	352,73	352,73	352,73	352,73
Shear from M_t			0	0	0	0	0	0	0	0
Circ shear from V_c			0	0	0	0	0	0	0	0
Long shear from V_L			0	0	0	0	0	0	0	0
Total Shear stress			0	0	0	0	0	0	0	0
Combined stress (P_L+P_b+Q)			716,147	751,16	716,147	751,16	597,398	903,937	597,398	903,937

* denotes primary stress.

Straight Flange on Ellipsoidal Head #1

ASME Section VIII Division 1, 2019 Edition Metric				
Component		Cylinder		
Material		SA-516 70 (II-D Metric p. 20, ln. 33)		
Impact Tested	Normalized	Fine Grain Practice	PWHT	Maximize MDMT/ No MAWP
No	No	No	No	No
		Design Pressure (bar)	Design Temperature (°C)	Design MDMT (°C)
Internal		21	120	-29
Static Liquid Head				
Condition		P_s (bar)	H_s (mm)	SG
Operating		0,09	901,7	1
Test horizontal		0,11	1.081,61	1
Dimensions				
Inner Diameter		889,4 mm		
Length		38 mm		
Nominal Thickness		12,5 mm		
Corrosion	Inner	0 mm		
	Outer	0 mm		
Weight and Capacity				
		Weight (kg)	Capacity (liters)	
New		10,54	23,61	
Corroded		10,54	23,61	
Radiography				
Longitudinal seam		Seamless No RT		
Left Circumferential seam		None UW-11(c) Type 1		

Results Summary	
Governing condition	Internal pressure
Minimum thickness per UG-16	1,5 mm + 0 mm = 1,5 mm
Design thickness due to internal pressure (t)	8.08 mm
Maximum allowable working pressure (MAWP)	32.34 bar
Maximum allowable pressure (MAP)	32.42 bar
Rated MDMT	-48 °C

UCS-66 Material Toughness Requirements	
Governing thickness, $t_g =$	12,5 mm
Exemption temperature from Fig UCS-66M Curve B =	-22,38°C
$t_r = 21,09 \cdot 444,7 / (1.380 \cdot 0,85 - 0.6 \cdot 21,09) =$	8,08 mm
Stress ratio = $t_r \cdot E^* / (t_n - c) = 8,08 \cdot 0,85 / (12,5 - 0) =$	0,5496
Reduction in MDMT, T_R from Fig UCS-66.1M =	27°C
MDMT = $\max[\text{MDMT} - T_R, -48] = \max[-22,38 - 27, -48] =$	-48°C
Material is exempt from impact testing at the Design MDMT of -29°C.	

Design thickness, (at 120 °C) UG-27(c)(1)

$$\begin{aligned}
 t &= P \cdot R / (S \cdot E - 0,60 \cdot P) + \text{Corrosion} \\
 &= 21,09 \cdot 444,7 / (1.380 \cdot 0,85 - 0,60 \cdot 21,09) + 0 \\
 &= \underline{8,08} \text{ mm}
 \end{aligned}$$

Maximum allowable working pressure, (at 120 °C) UG-27(c)(1)

$$\begin{aligned}
 P &= S \cdot E \cdot t / (R + 0,60 \cdot t) - P_s \\
 &= 1.380 \cdot 0,85 \cdot 12,5 / (444,7 + 0,60 \cdot 12,5) - 0,09 \\
 &= \underline{32,34} \text{ bar}
 \end{aligned}$$

Maximum allowable pressure, (at 21,11 °C) UG-27(c)(1)

$$\begin{aligned}
 P &= S \cdot E \cdot t / (R + 0,60 \cdot t) \\
 &= 1.380 \cdot 0,85 \cdot 12,5 / (444,7 + 0,60 \cdot 12,5) \\
 &= \underline{32,42} \text{ bar}
 \end{aligned}$$

% Extreme fiber elongation - UCS-79(d)

$$\begin{aligned}
 \text{EFE} &= (50 \cdot t / R_f) \cdot (1 - R_f / R_o) \\
 &= (50 \cdot 12,5 / 450,95) \cdot (1 - 450,95 / \text{infinity}) \\
 &= 1,386\%
 \end{aligned}$$

The extreme fiber elongation does not exceed 5%.

Johnson Controls BE do Brasil Ltda

Av. Independência 2757 - Planta BE - Éden Sorocaba-SP

www.johnsoncontrols.com.br

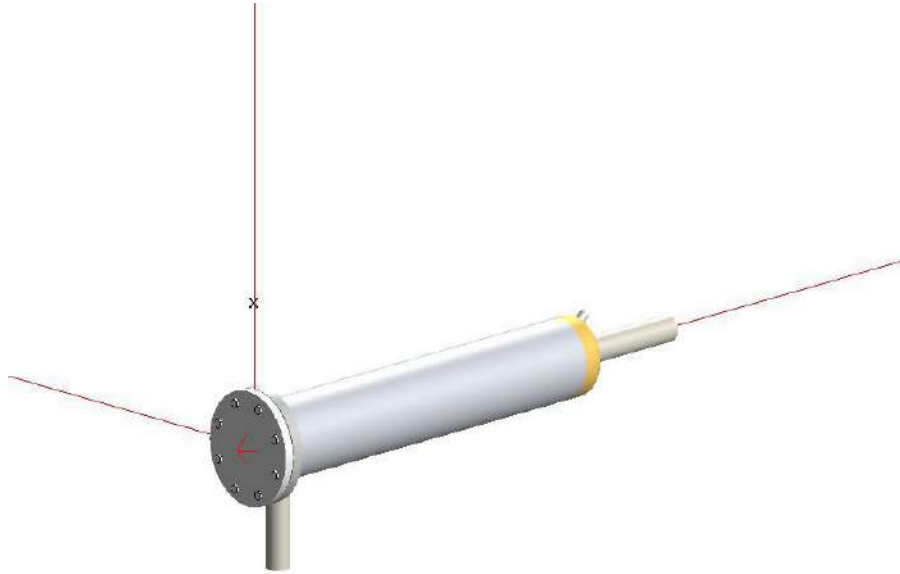

COMPRESS Pressure Vessel Design Calculations

Description/Model: Oil Filter - CX-DN.2.1/2"

Drawing 553E0014BR

Data/Revision: 06/02/2020 - Rev. 0

Designed/Approved: Alexandre Almeida / Leandro Martinez

Customer, as required by U-2, did not specify loadings found in UG-22 paragraphs (c), (d)(1), (e), (f), (g), (h), (i), and (j). Vessel is specified for use in non-corrosive and non-lethal refrigeration service.

Table of Contents

Nozzle Schedule	1
Nozzle Summary	2
Pressure Summary	3
Settings Summary	4
Radiography Summary	6
Thickness Summary	7
Weight Summary	8
Pneumatic Test	9
Bill of Materials	10
Bolted Cover	11
Shell	13
Flange	15
Straight Flange on B16.9 Pipe Cap	17
B16.9 Pipe Cap	19
Oil Inlet (A)	21
Oil Outlet (B)	26
Vent/Relief (C)	29
Vent/Relief (C)	33

Nozzle Schedule

Specifications									
Nozzle mark	Identifier	Size	Materials		Impact Tested	Normalized	Fine Grain	Flange	Blind
A	Oil Inlet	NPS 2,5 Sch 40 (Std) DN 65	Nozzle	SA-106 B Smis Pipe	No	No	No	N/A	No
B	Oil Outlet	NPS 2,5 Sch 40 (Std) DN 65	Nozzle	SA-106 B Smis Pipe	No	No	No	N/A	No
C	Vent/Relief	NPS 0,5 Class 3000 DN 15 - Threaded Full Coupling (47,75 mm length)	Nozzle	SA-105	No	No	No	N/A	No
C	Vent/Relief	NPS 0,5 Class 3000 DN 15 - Threaded Full Coupling	Nozzle	SA-105	No	No	No	N/A	No

Nozzle Summary

Dimensions												
Nozzle mark	OD (mm)	t _n (mm)	Req t _n (mm)	A ₁ ?	A ₂ ?	Shell			Reinforcement Pad		Corr (mm)	A _a /A _r (%)
						Nom t (mm)	Design t (mm)	User t (mm)	Width (mm)	t _{pad} (mm)		
<u>A</u>	73,02	5,16	2,65	Yes	Yes	8,18	2,32		N/A	N/A	0	311,7
<u>B</u>	73,02	5,16	2,94	Yes	Yes	8,18	N/A		N/A	N/A	0	Exempt
<u>C</u>	28,45	3,56	1,5	Yes	Yes	8,18	N/A		N/A	N/A	0	Exempt
<u>C</u>	28,45	3,56	1,5	Yes	Yes	8,18	N/A		N/A	N/A	0	Exempt

*Head minimum thickness after forming

Definitions	
t _n	Nozzle thickness
Req t _n	Nozzle thickness required per UG-45/UG-16 Increased for pipe to account for 12.5% pipe thickness tolerance
Nom t	Vessel wall thickness
Design t	Required vessel wall thickness due to pressure + corrosion allowance per UG-37
User t	Local vessel wall thickness (near opening)
A _a	Area available per UG-37, governing condition
A _r	Area required per UG-37, governing condition
Corr	Corrosion allowance on nozzle wall

Pressure Summary

Component Summary							
Identifier	P Design (bar)	T Design (°C)	MAWP (bar)	MAP (bar)	MDMT (°C)	MDMT Exemption	Impact Tested
Bolted Cover	28	120	43,01	43,01	-48	Note 1	No
Shell	28	120	67,3	67,3	-48	Note 2	No
Straight Flange on B16.9 Pipe Cap	28	120	77,21	77,21	-105	Note 4	No
B16.9 Pipe Cap	28	120	69,64	69,64	-105	Note 3	No
Flange	28	120	28,4	28,4	-29,8	Note 5	No
Oil Inlet (A)	28	120	56,22	56,22	-105	Note 6	No
Oil Outlet (B)	28	120	79,18	79,18	-105	Note 6	No
Vent/Relief (C)	28	120	81,93	81,93	-105	Note 7	No
Vent/Relief (C)	28	120	81,93	81,93	-105	Note 7	No

Chamber Summary	
Design MDMT	-29 °C
Rated MDMT	-29,8 °C @ 28 bar
MAWP hot & corroded	28 bar @ 120 °C
MAP cold & new	28,4 bar @ 0 °C

(1) The MAWP is limited due to the MAWP limit set in the Calculations tab of the Set Mode dialog.
(2) This pressure chamber is not designed for external pressure.

Notes for MDMT Rating		
Note #	Exemption	Details
1.	Bolted cover impact test exemption temperature from Fig UCS-66M Curve B = -29°C Fig UCS-66.1M MDMT reduction = 19,5°C, (coincident ratio = 0,6509) Rated MDMT of -48,5°C is limited to -48°C by UCS-66(b)(2)	UCS-66 governing thickness = 7,25 mm
2.	Material impact test exemption temperature from Fig UCS-66M Curve B = -29°C Fig UCS-66.1M MDMT reduction = 71,4°C, (coincident ratio = 0,3591) Rated MDMT of -100,4°C is limited to -48°C by UCS-66(b)(2)	UCS-66 governing thickness = 7,16 mm
3.	Straight Flange governs MDMT	
4.	Material is impact test exempt to -105°C per UCS-66(b)(3) (coincident ratio = 0,3142)	
5.	UCS-66(b)(1)(b) has been applied. Flange impact test exemption temperature from Fig UCS-66M Curve B = -29°C Fig UCS-66.1M MDMT reduction = 0,8°C, (coincident ratio = 0,9859) UCS-66 governing thickness = 7,16 mm	Bolts rated MDMT per Fig UCS-66 note (c) = -48°C
6.	Nozzle is impact test exempt per UCS-66(d) (NPS 4 or smaller pipe).	
7.	Nozzle is impact test exempt to -105°C per UCS-66(b)(3) (coincident ratio = 0,0616).	

Settings Summary

COMPRESS 2020 Build 8000	
ASME Section VIII Division 1, 2019 Edition Metric	
Units	MKS
Datum Line Location	0,00 mm from left seam
Vessel Design Mode	Design Mode
Minimum thickness	1,5 mm per UG-16(b)
Design for cold shut down only	No
Design for lethal service (full radiography required)	No
User has limited MAWP to	28 bar
Design nozzles for	Design P only
Corrosion weight loss	100% of theoretical loss
UG-23 Stress Increase	1,20
Skirt/legs stress increase	1,0
Minimum nozzle projection	6,35 mm
Juncture calculations for $\alpha > 30$ only	Yes
Preheat P-No 1 Materials $> 1,25"$ and $\leq 1,50"$ thick	No
UG-37(a) shell tr calculation considers longitudinal stress	No
Cylindrical shells made from pipe are entered as minimum thickness	No
Nozzles made from pipe are entered as minimum thickness	No
ASME B16.9 fittings are entered as minimum thickness	No
Butt welds	Tapered per Figure UCS-66.3(a)
Disallow Appendix 1-5, 1-8 calculations under 15 psi	No
Hydro/Pneumatic Test	
Shop Pneumatic Test Pressure	1,1 times vessel MAWP [UG-100(b)]
Test liquid specific gravity	1,00
Maximum stress during test	90% of yield
Required Marking - UG-116	
UG-116(e) Radiography	None
UG-116(f) Postweld heat treatment	None
Code Cases/Interpretations	
Use Code Case 2547	No
Use Appendix 46	No
Use UG-44(b)	No
Use Code Case 2955	No
Apply interpretation VIII-1-83-66	No
Apply interpretation VIII-1-86-175	No
Apply interpretation VIII-1-01-37	No
Apply interpretation VIII-1-01-150	No
Apply interpretation VIII-1-07-50	No

Apply interpretation VIII-1-16-85	No
No UCS-66.1 MDMT reduction	No
No UCS-68(c) MDMT reduction	No
Disallow UG-20(f) exemptions	Yes
UG-22 Loadings	
UG-22(a) Internal or External Design Pressure	Yes
UG-22(b) Weight of the vessel and normal contents under operating or test conditions	No
UG-22(c) Superimposed static reactions from weight of attached equipment (external loads)	No
UG-22(d)(2) Vessel supports such as lugs, rings, skirts, saddles and legs	No
UG-22(f) Wind reactions	No
UG-22(f) Seismic reactions	No
UG-22(j) Test pressure and coincident static head acting during the test:	No
Note: UG-22(b),(c) and (f) loads only considered when supports are present.	
Note 2: UG-22(d)(1),(e),(f)-snow,(g),(h),(i) are not considered. If these loads are present, additional calculations must be performed.	

License Information	
Company Name	Johnson Controls Be Do Brasil Ltda.
License	Commercial
License Key ID	23460
Support Expires	June 26, 2020

Radiography Summary

UG-116 Radiography							
Component	Longitudinal Seam		Left Circumferential Seam		Right Circumferential Seam		Mark
	Category (Fig UW-3)	Radiography / Joint Type	Category (Fig UW-3)	Radiography / Joint Type	Category (Fig UW-3)	Radiography / Joint Type	
Bolted Cover	N/A	Seamless No RT	N/A	N/A	N/A	N/A / Gasketed	N/A
Shell	N/A	Seamless No RT	C	N/A	B	None UW-11(c) / Type 1	None
Flange	N/A	Seamless No RT	N/A	N/A / Gasketed	C	N/A	N/A
B16.9 Pipe Cap	N/A	Seamless No RT	B	None UW-11(c) / Type 1	N/A	N/A	None
Nozzle	Longitudinal Seam		Nozzle to Vessel Circumferential Seam		Nozzle free end Circumferential Seam		
Oil Outlet (B)	N/A	Seamless No RT	D	N/A / Type 7	N/A	N/A	N/A
Oil Inlet (A)	N/A	Seamless No RT	D	N/A / Type 7	N/A	N/A	N/A
Vent/Relief (C)	N/A	Seamless No RT	D	N/A / Type 7	N/A	N/A	N/A
Vent/Relief (C)	N/A	Seamless No RT	D	N/A / Type 7	N/A	N/A	N/A
UG-116(e) Required Marking: None							

Thickness Summary

Component Data								
Component Identifier	Material	Diameter (mm)	Length (mm)	Nominal t (mm)	Design t (mm)	Total Corrosion (mm)	Joint E	Load
Bolted Cover	SA-516 70	314 OD	29	29	23,4	0	1,00	Internal
Shell	SA-106 B Smls Pipe	219,07 OD	1.249	8,18	3,03	0	0,85	Internal
Straight Flange on B16.9 Pipe Cap	SA-234 WPB	219,07 OD	44,16	8,18	3,03	0	0,85	Internal
B16.9 Pipe Cap	SA-234 WPB	219,07 OD	57,83	8,18	2,98	0	0,85	Internal

Definitions	
Nominal t	Vessel wall nominal thickness
Design t	Required vessel thickness due to governing loading + corrosion
Joint E	Longitudinal seam joint efficiency
Load	
Internal	Circumferential stress due to internal pressure governs
External	External pressure governs
Wind	Combined longitudinal stress of pressure + weight + wind governs
Seismic	Combined longitudinal stress of pressure + weight + seismic governs

Weight Summary

Weight (kg) Contributed by Vessel Elements											
Component	Metal New*	Metal Corroded	Insulation	Insulation Supports	Lining	Piping + Liquid	Operating Liquid		Test Liquid		Surface Area m ²
							New	Corroded	New	Corroded	
Bolted Cover	17,6	17,6	0	0	0	0	0	0	0	0	0,11
Shell	52,8	52,8	0	0	0	0	0	0	41,5	41,5	0,86
B16.9 Pipe Cap	4,9	4,9	0	0	0	0	0	0	3,6	3,6	0,08
TOTAL:	75,2	75,2	0	0	0	0	0	0	45,1	45,1	1,04

*Shells with attached nozzles have weight reduced by material cut out for opening.

Weight (kg) Contributed by Attachments										
Component	Body Flanges		Nozzles & Flanges		Packed Beds	Trays	Tray Supports	Rings & Clips	Vertical Loads	Surface Area m ²
	New	Corroded	New	Corroded						
Bolted Cover	0	0	0	0	0	0	0	0	0	0
Shell	11	11	2,2	2,2	0	0	0	0	0	0,09
B16.9 Pipe Cap	0	0	3,3	3,3	0	0	0	0	0	0,09
TOTAL:	11	11	5,5	5,5	0	0	0	0	0	0,18

Vessel Totals		
	New	Corroded
Operating Weight (kg)	92	92
Empty Weight (kg)	92	92
Test Weight (kg)	137	137
Surface Area (m ²)	1,22	-
Capacity** (liters)	43	43

**The vessel capacity does not include volume of nozzle, piping or other attachments.

Vessel Lift Condition	
Vessel Lift Weight, New (kg)	92
Center of Gravity from Datum (mm)	495,1

Pneumatic Test

Horizontal shop pneumatic test based on MAWP per UG-100(b)

$$\begin{aligned} \text{Gauge pressure at } 0^{\circ}\text{C} &= 1,1 \cdot \text{MAWP} \cdot \text{LSR} \\ &= 1,1 \cdot 28 \cdot 1 \\ &= 30,8 \text{ bar} \end{aligned}$$

Horizontal shop pneumatic test				
Identifier	Local test pressure (bar)	Test liquid static head (bar)	UG-100(b) stress ratio	UG-100(b) pressure factor
Shell (1)	30,82	0,02	1	1,10
Straight Flange on B16.9 Pipe Cap	30,82	0,02	1	1,10
B16.9 Pipe Cap	30,82	0,02	1	1,10
Bolted Cover	30,82	0,02	1	1,10
Flange	30,82	0,02	1	1,10
Oil Inlet (A)	30,81	0,01	1	1,10
Oil Outlet (B)	30,84	0,04	1	1,10
Vent/Relief (C)	30,82	0,02	1	1,10
Vent/Relief (C)	30,8	0	1	1,10

(1) Shell limits the UG-100(b) stress ratio.
 (2) The zero degree angular position is assumed to be up, and the test liquid height is assumed to the top-most flange.

The field test condition has not been investigated.

The test temperature of 0 °C is warmer than the minimum required temperature of -12,8 °C so the brittle fracture provision of UG-100(c) has been met.

Bill of Materials

Covers						
Item #	Type	Material	Thk [mm]	Dia. [mm]	Wt. [kg] (ea.)	Qty
H1	Bolted Cover	SA-516 70	29	314 OD	17,6	1

Shells							
Item #	Type	Material	Thk [mm]	Dia. [mm]	Length [mm]	Wt. [kg] (ea.)	Qty
S1	Cylinder	SA-106 B Smls Pipe; NPS 8 Sch 40 (Std) DN 200	8,18	219,07 OD	1.249	53	1

Nozzles							
Item #	Type	Material	NPS	Thk [mm]	Dia. [mm]	Length [mm]	Wt. [kg]
Noz1	Nozzle	SA-106 B Smls Pipe	NPS 2,5 Sch 40 (Std) DN 65	5,16	73,02 OD	610	5,3

Nozzles - Couplings					
Item #	Type	Material	Dia. [mm]	Length [mm]	Qty
C1	NPS 0,5 Class 3000 DN 15 - Threaded Full Coupling (custom)	SA-105	28,45 OD	47,75	1
C2	NPS 0,5 Class 3000 DN 15 - Threaded Full Coupling	SA-105	28,45 OD	47,75	1

ASME B16.9 Fittings				
Item #	Type	Material	Size [mm]	Qty
H1	B16.9 Pipe Cap	SA-234 WPB	NPS 8 Sch 40 (Std) DN 200	1

Flanges						
Item #	Type	Material	NPS	Dia. [mm]	Wt. [kg] (ea.)	Qty
CF1	Ring type loose	SA-516 70	-	314 x 222,3	11	1

Gaskets				
Item #	Type	Size [mm]	Thk [mm]	Qty
G1	Garlock BLUE-GARD - 1/16" 3300 Aramid Fibers / Neoprene Binder (Flat Nonmetallic)	248 x 222,3	1,6	1

Fasteners				
Item #	Description	Material	Length [mm]	Qty
FB1	5/8" coarse bolt	SA-193 B7 Bolt <= 64	114	8

All listed flange bolts require associated nuts and washers in accordance with Division 1, UCS-11.

Bolted Cover

ASME Section VIII Division 1, 2019 Edition Metric				
Component		Bolted Cover		
Material		SA-516 70 (II-D Metric p. 20, ln. 33)		
Attached To		Flange		
Impact Tested	Normalized	Fine Grain Practice	PWHT	Maximize MDMT/ No MAWP
No	No	No	No	No
		Design Pressure (bar)	Design Temperature (°C)	Design MDMT (°C)
Internal		28	120	-29
Static Liquid Head				
Condition		P_s (bar)	H_s (mm)	SG
Test horizontal		0,02	222,3	1
Dimensions				
Outer Diameter		314 mm		
Bolt Circle, BC		276 mm		
Nominal Thickness		29 mm		
Corrosion	Inner	0 mm		
	Outer	0 mm		
Weight and Capacity				
		Weight (kg)		Capacity (liters)
New		17,59		0
Corroded		17,59		0
Radiography				
Category A joints		Seamless No RT		

Results Summary	
Governing condition	internal pressure
Minimum thickness per UG-16	1,5 mm + 0 mm = 1,5 mm
Design thickness due to internal pressure (t)	23,4 mm
Design thickness due to gasket seating	14,56 mm
Maximum allowable working pressure (MAWP)	43,01 bar
Maximum allowable pressure (MAP)	43,01 bar
Rated MDMT	-48°C

UCS-66 Material Toughness Requirements	
Governing thickness, $t_g =$	7,25 mm
Exemption temperature from Fig UCS-66M Curve B =	-29°C
Stress ratio per UCS-66(b)(1)(b) = $28 / 43,01 =$	0,6509
Reduction in MDMT, T_R from Fig UCS-66.1M =	19,5°C
MDMT = $\max[\text{MDMT} - T_R, -48] = \max[-29 - 19,5 , -48] =$	-48°C
Material is exempt from impact testing at the Design MDMT of -29°C.	

Figure UG-34 Diameter

$$\begin{aligned}
 d &= BC - 2 \cdot h_G \\
 &= 276 - 2 \cdot 20,34 \\
 &= 235,33 \text{ mm}
 \end{aligned}$$

Design thickness, (at 120 °C) UG-34(c)(2), flange operating

$$\begin{aligned}
 t &= d \cdot \text{Sqr}(C \cdot P / (S \cdot E) + 1,9 \cdot W \cdot h_G / (S \cdot E \cdot d^3)) + \text{Corrosion} \\
 &= 235,33 \cdot \text{Sqr}(0,3 \cdot 28,55 / (1.407,208 \cdot 1) + 100 \cdot 1,9 \cdot 18.027,63 \cdot 20,34 / (1.407,208 \cdot 1 \cdot 235,33^3)) + 0 \\
 &= \underline{23,4} \text{ mm}
 \end{aligned}$$

Design thickness, (at 0 °C) UG-34(c)(2), gasket seating

$$\begin{aligned}
 t &= d \cdot \text{Sqr}(1,9 \cdot W \cdot h_G / (S \cdot E \cdot d^3)) + \text{Corrosion} \\
 &= 10 \cdot 235,33 \cdot \text{Sqr}(1,9 \cdot 18.156,77 \cdot 20,34 / (1.407,208 \cdot 1 \cdot 235,33^3)) + 0 \\
 &= \underline{14,56} \text{ mm}
 \end{aligned}$$

Maximum allowable working pressure, (at 120 °C)

$$\begin{aligned}
 P &= (S \cdot E / C) \cdot ((t / d)^2 - (1,9 \cdot W \cdot h_G / (S \cdot E \cdot d^3))) - P_s \\
 &= (1.407,208 / 1,02 \cdot 1 / 0,3) \cdot ((29 / 235,33)^2 - (1,9 \cdot 100 \cdot 27.694,66 \cdot 20,34 / (1.407,208 \cdot 1 \cdot 235,33^3))) - 0 \\
 &= \underline{43,01} \text{ bar}
 \end{aligned}$$

Maximum allowable pressure, (at 0 °C)

$$\begin{aligned}
 P &= (S \cdot E / C) \cdot ((t / d)^2 - (1,9 \cdot W \cdot h_G / (S \cdot E \cdot d^3))) \\
 &= (1.407,208 / 1,02 \cdot 1 / 0,3) \cdot ((29 / 235,33)^2 - (1,9 \cdot 100 \cdot 27.694,66 \cdot 20,34 / (1.407,208 \cdot 1 \cdot 235,33^3))) \\
 &= \underline{43,01} \text{ bar}
 \end{aligned}$$

Shell

ASME Section VIII Division 1, 2019 Edition Metric				
Component		Cylinder		
Material		SA-106 B Smls Pipe (II-D Metric p. 16, In. 10)		
Pipe NPS and Schedule		NPS 8 Sch 40 (Std) DN 200		
Impact Tested	Normalized	Fine Grain Practice	PWHT	Maximize MDMT/ No MAWP
No	No	No	No	No
		Design Pressure (bar)	Design Temperature (°C)	Design MDMT (°C)
Internal		28	120	-29
Static Liquid Head				
Condition		P_s (bar)	H_s (mm)	SG
Test horizontal		0,02	212,51	1
Dimensions				
Outer Diameter		219,07 mm		
Length		1.249 mm		
Pipe Nominal Thickness		8,18 mm		
Pipe Minimum Thickness¹		7,16 mm		
Corrosion	Inner	0 mm		
	Outer	0 mm		
Weight and Capacity				
		Weight (kg)	Capacity (liters)	
New		52,75	40,31	
Corroded		52,75	40,31	
Radiography				
Longitudinal seam		Seamless No RT		
Right Circumferential seam		None UW-11(c) Type 1		

¹Pipe minimum thickness = nominal thickness times pipe tolerance factor of 0,875.

Results Summary	
Governing condition	Internal pressure
Minimum thickness per UG-16	1,5 mm + 0 mm = 1,5 mm
Design thickness due to internal pressure (t)	3.03 mm
Maximum allowable working pressure (MAWP)	67.3 bar
Maximum allowable pressure (MAP)	67.3 bar
Rated MDMT	-48 °C

UCS-66 Material Toughness Requirements	
Governing thickness, $t_g =$	7,16 mm
Exemption temperature from Fig UCS-66M Curve B =	-29°C
$t_r = 28 \cdot 109,54 / (1.180 \cdot 0,85 + 0.4 \cdot 28) =$	3,02 mm
Stress ratio = $t_r \cdot E^* / (t_n - c) = 3,02 \cdot 0,85 / (7,16 - 0) =$	0,3591
Reduction in MDMT, T_R from Fig UCS-66.1M =	71,4°C
MDMT = $\max[\text{MDMT} - T_R, -48] = \max[-29 - 71,4, -48] =$	-48°C
Material is exempt from impact testing at the Design MDMT of -29°C.	

Design thickness, (at 120 °C) Appendix 1-1

$$\begin{aligned}
 t &= P \cdot R_o / (S \cdot E + 0,40 \cdot P) + \text{Corrosion} \\
 &= 28 \cdot 109,54 / (1.180 \cdot 0,85 + 0,40 \cdot 28) + 0 \\
 &= \underline{3,03} \text{ mm}
 \end{aligned}$$

Maximum allowable working pressure, (at 120 °C) Appendix 1-1

$$\begin{aligned}
 P &= S \cdot E \cdot t / (R_o - 0,40 \cdot t) - P_s \\
 &= 1.180 \cdot 0,85 \cdot (8,18 \cdot 0,875) / (109,54 - 0,40 \cdot (8,18 \cdot 0,875)) - 0 \\
 &= \underline{67,3} \text{ bar}
 \end{aligned}$$

Maximum allowable pressure, (at 0 °C) Appendix 1-1

$$\begin{aligned}
 P &= S \cdot E \cdot t / (R_o - 0,40 \cdot t) \\
 &= 1.180 \cdot 0,85 \cdot (8,18 \cdot 0,875) / (109,54 - 0,40 \cdot (8,18 \cdot 0,875)) \\
 &= \underline{67,3} \text{ bar}
 \end{aligned}$$

Flange

ASME Section VIII Division 1, 2019 Edition Metric , Appendix 2 Flange Calculations				
Flange Type		Ring type loose		
Attachment Type		Figure 2-4 sketch (3a)		
Flange Material		SA-516 70 (II-D Metric p. 20, In. 33)		
Attached To		Shell (Left)		
Impact Tested	Normalized	Fine Grain Practice	PWHT	Maximize MDMT/ No MAWP
No	No	No	No	No
		Design Pressure (bar)	Design Temperature (°C)	Design MDMT (°C)
Internal		28	120	-29
Static Liquid Head				
Condition		P_s (bar)		
Operating		0		
Dimensions				
Flange OD, A	314 mm			
Flange ID, B	222,3 mm			
Bolt Circle, C	276 mm			
Gasket OD	248 mm			
Gasket ID	222,3 mm			
Raised Face OD	251 mm			
Facing Height, t_{rf}	1,6 mm			
Flange Thickness, t	35,9 mm			
Fillet Weld, h	8,5 mm			
Fillet Weld, h₁	8,18 mm			
Length, e	9,5 mm			
Corrosion Bore	0 mm			
Corrosion Flange	0 mm			
Bolting				
Material	SA-193 B7 Bolt <= 64 (II-D Metric p. 398, In. 32)			
Description	8 - 0,625" coarse threaded			
Corrosion on root	0 mm			
Gasket				
Type	Nonmetallic Flat Gasket			
Description	Garlock BLUE-GARD - 1/16" 3300 Aramid Fibers / Neoprene Binder			
Factor, m	2,1			
Seating Stress, y	214,436 kg _f /cm ²			
Thickness, T	1,6 mm			

Weight (kg)	
New	10,98 kg
Corroded	10,98 kg
Radiography	
Longitudinal seam	Seamless No RT
Right Circumferential seam	N/A

Results Summary		
Flange design thickness:	32,7 mm	
Maximum allowable working pressure, MAWP:	28,4 bar @ 120 °C	(bolting limits)
Maximum allowable pressure, MAP:	28,4 bar @ 0 °C	(bolting limits)
Rated MDMT	-29,8 °C	

Note: this flange is calculated as a loose type.

UCS-66 Material Toughness Requirements	
Governing thickness, $t_g =$	7,16 mm
Exemption temperature from Fig UCS-66M Curve B =	-29°C
Stress ratio per UCS-66(b)(1)(b) = $28 / 28,4 =$	0,9859
Reduction in MDMT, T_R from Fig UCS-66.1M =	0,8°C
MDMT = $\max[\text{MDMT} - T_R, -48] = \max[-29 - 0,8, -48] =$	-29,8°C
Bolts rated MDMT per Fig UCS-66 note (c) =	-48°C
Material is exempt from impact testing at the Design MDMT of -29°C.	

Stress Summary					
			P (bar)	S_T (kgf/ cm ²)	Allow (kgf/ cm ²)
Design P	Weight Only	Oper	28	895,195	1.407,208
		Seating			

Bolt Summary						
			P (bar)	W (kgf)	A_m (cm ²)	A_b (cm ²)
Design P	Weight Only	Oper	28	18.027,63	10,28	10,43
		Seating				

Rigidity Summary					
			P (bar)	J	Allow
Design P	Weight Only	Oper	28	0,7559	1
		Seating			

Straight Flange on B16.9 Pipe Cap

ASME Section VIII Division 1, 2019 Edition Metric				
Component		Cylinder		
Material		SA-234 WPB (II-D Metric p. 16, ln. 12)		
Impact Tested	Normalized	Fine Grain Practice	PWHT	Maximize MDMT/ No MAWP
No	No	No	No	No
		Design Pressure (bar)	Design Temperature (°C)	Design MDMT (°C)
Internal		28	120	-29
Static Liquid Head				
Condition		P_s (bar)	H_s (mm)	SG
Test horizontal		0,02	212,51	1
Dimensions				
Outer Diameter		219,07 mm		
Length		44,17 mm		
Nominal Thickness		8,18 mm		
Corrosion	Inner	0 mm		
	Outer	0 mm		
Weight and Capacity				
		Weight (kg)	Capacity (liters)	
New		1,87	1,43	
Corroded		1,87	1,43	
Radiography				
Longitudinal seam		Seamless No RT		
Left Circumferential seam		None UW-11(c) Type 1		

Results Summary	
Governing condition	Internal pressure
Minimum thickness per UG-16	1,5 mm + 0 mm = 1,5 mm
Design thickness due to internal pressure (t)	3.03 mm
Maximum allowable working pressure (MAWP)	77.21 bar
Maximum allowable pressure (MAP)	77.21 bar
Rated MDMT	-105 °C

UCS-66 Material Toughness Requirements	
$t_r = 28 * 109,54 / (1.180 * 0,85 + 0.4 * 28) =$	3,02 mm
Stress ratio = $t_r * E^* / (t_n - c) = 3,02 * 0,85 / (8,18 - 0) =$	0,3142
Stress ratio $\leq 0,35$, MDMT per UCS-66(b)(3) =	-105°C
Material is exempt from impact testing at the Design MDMT of -29°C.	

Design thickness, (at 120 °C) Appendix 1-1

$$\begin{aligned} t &= P \cdot R_o / (S \cdot E + 0,40 \cdot P) + \text{Corrosion} \\ &= 28 \cdot 109,54 / (1.180 \cdot 0,85 + 0,40 \cdot 28) + 0 \\ &= \underline{3,03} \text{ mm} \end{aligned}$$

Maximum allowable working pressure, (at 120 °C) Appendix 1-1

$$\begin{aligned} P &= S \cdot E \cdot t / (R_o - 0,40 \cdot t) - P_s \\ &= 1.180 \cdot 0,85 \cdot 8,18 / (109,54 - 0,40 \cdot 8,18) - 0 \\ &= \underline{77,21} \text{ bar} \end{aligned}$$

Maximum allowable pressure, (at 0 °C) Appendix 1-1

$$\begin{aligned} P &= S \cdot E \cdot t / (R_o - 0,40 \cdot t) \\ &= 1.180 \cdot 0,85 \cdot 8,18 / (109,54 - 0,40 \cdot 8,18) \\ &= \underline{77,21} \text{ bar} \end{aligned}$$

B16.9 Pipe Cap

ASME Section VIII Division 1, 2019 Edition Metric				
Component		ASME B16.9 Pipe Cap (modified)		
Material		SA-234 WPB (II-D Metric p. 16, ln. 12)		
Attached To		Shell		
Impact Tested	Normalized	Fine Grain Practice	PWHT	Maximize MDMT/ No MAWP
No	No	No	No	No
		Design Pressure (bar)	Design Temperature (°C)	Design MDMT (°C)
Internal		28	120	-29
Static Liquid Head				
Condition		P_s (bar)	H_s (mm)	SG
Test horizontal		0,02	212,51	1
Dimensions				
NPS and Schedule		NPS 8 Sch 40 (Std) DN 200		
Outer Diameter		219,07 mm		
Overall Length E		102 mm		
Nominal Thickness		8,18 mm		
Minimum Thickness¹		7,16 mm		
Corrosion	Inner	0 mm		
	Outer	0 mm		
Length L_{sf}		44,17 mm		
Nominal Thickness t_{sf}		8,18 mm		
Weight and Capacity				
		Weight (kg)²	Capacity (liters)²	
New		4,87	2,52	
Corroded		4,87	2,52	
Radiography				
Category A joints		Seamless No RT		
Head to shell seam		None UW-11(c) Type 1		

¹ minimum thickness = nominal thickness times pipe tolerance factor of 0,875.

² includes straight flange

Results Summary	
Governing condition	internal pressure
Minimum thickness per UG-16	1,5 mm + 0 mm = 1,5 mm
Design thickness due to internal pressure (t)	2,98 mm
Governing straight flange design thickness	3,03 mm
Maximum allowable working pressure (MAWP)	69,64 bar
Maximum allowable pressure (MAP)	69,64 bar
Straight Flange governs MDMT	-105°C

Factor K		
$K = (1/6) * [2 + (D / (2 * h))^2]$		
Corroded	$K = (1/6) * [2 + (202,71 / (2 * 50,68))^2]$	1
New	$K = (1/6) * [2 + (202,71 / (2 * 50,68))^2]$	1

Design thickness for internal pressure, (Corroded at 120 °C) Appendix 1-4(c)

$$\begin{aligned}
 t &= P * D_o * K / (2 * S * E + 2 * P * (K - 0,1)) + \text{Corrosion} \\
 &= 28 * 219,07 * 1 / (2 * 1.180 * 0,85 + 2 * 28 * (1 - 0,1)) + 0 \\
 &= \a href="#">2,98 \text{ mm}
 \end{aligned}$$

Maximum allowable working pressure, (Corroded at 120 °C) Appendix 1-4(c)

$$\begin{aligned}
 P &= 2 * S * E * t / (K * D_o - 2 * t * (K - 0,1)) - P_s \\
 &= 2 * 1.180 * 0,85 * 0,875 * 8,18 / (1 * 219,07 - 2 * 0,875 * 8,18 * (1 - 0,1)) - 0 \\
 &= \a href="#">69,64 \text{ bar}
 \end{aligned}$$

Maximum allowable pressure, (New at 0 °C) Appendix 1-4(c)

$$\begin{aligned}
 P &= 2 * S * E * t / (K * D_o - 2 * t * (K - 0,1)) - P_s \\
 &= 2 * 1.180 * 0,85 * 0,875 * 8,18 / (1 * 219,07 - 2 * 0,875 * 8,18 * (1 - 0,1)) - 0 \\
 &= \a href="#">69,64 \text{ bar}
 \end{aligned}$$

Oil Inlet (A)

ASME Section VIII Division 1, 2019 Edition Metric

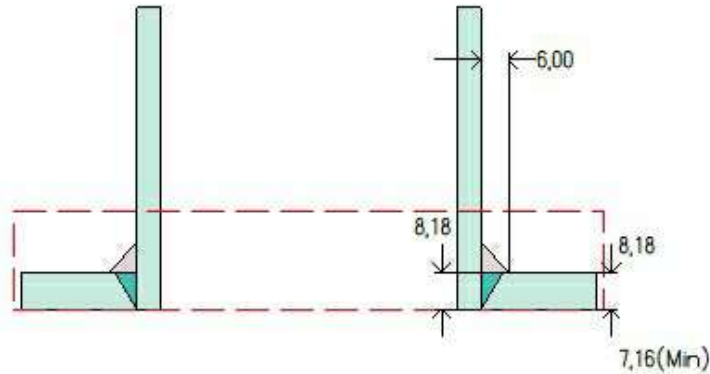

Note: round inside edges per UG-76(c)

Location and Orientation

Located on	B16.9 Pipe Cap
Orientation	0°
End of nozzle to datum line	1.711,28 mm
Calculated as hillside	No
Distance to head center, R	0 mm
Passes through a Category A joint	No

Nozzle

Description	NPS 2,5 Sch 40 (Std) DN 65
Access opening	No
Material specification	SA-106 B Smls Pipe (II-D Metric p. 16, In. 10)
Inside diameter, new	62,71 mm
Pipe nominal wall thickness	5,16 mm
Pipe minimum wall thickness ¹	4,51 mm
Corrosion allowance	0 mm
Projection available outside vessel, Lpr	350,89 mm
Local vessel minimum thickness	7,16 mm
Liquid static head included	0 bar
Longitudinal joint efficiency	1

Welds

Inner fillet, Leg ₄₁	6 mm
Nozzle to vessel groove weld	8,18 mm

¹Pipe minimum thickness = nominal thickness times pipe tolerance factor of 0,875.

UCS-66 Material Toughness Requirements Nozzle	
---	--

Impact test exempt per UCS-66(d) (NPS 4 or smaller pipe) =	-105°C
--	--------

Material is exempt from impact testing at the Design MDMT of -29°C.	
---	--

Reinforcement Calculations for Internal Pressure

UG-37 Area Calculation Summary (cm ²)							UG-45 Summary (mm)	
For P = 28 bar @ 120 °C The opening is adequately reinforced							The nozzle passes UG-45	
A required	A available	A ₁	A ₂	A ₃	A ₅	A welds	t _{req}	t _{min}
1,4532	4,5303	3,0355	1,1348	-	-	0,36	2,32	4,51

UG-41 Weld Failure Path Analysis Summary
The nozzle is exempt from weld strength calculations per UW-15(b)(1)

UW-16 Weld Sizing Summary			
Weld description	Required weld throat size (mm)	Actual weld throat size (mm)	Status
Nozzle to shell fillet (Leg ₄₁)	3,61	4,2	weld size is adequate

Calculations for internal pressure 28 bar @ 120 °C

Parallel Limit of reinforcement per UG-40

$$\begin{aligned}
 L_R &= \text{MAX}(d, R_n + (t_n - C_n) + (t - C)) \\
 &= \text{MAX}(62,71, 31,36 + (5,16 - 0) + (7,16 - 0)) \\
 &= 62,71 \text{ mm}
 \end{aligned}$$

Outer Normal Limit of reinforcement per UG-40

$$\begin{aligned}
 L_H &= \text{MIN}(2,5*(t - C), 2,5*(t_n - C_n) + t_e) \\
 &= \text{MIN}(2,5*(7,16 - 0), 2,5*(5,16 - 0) + 0) \\
 &= 12,89 \text{ mm}
 \end{aligned}$$

Nozzle required thickness per UG-27(c)(1)

$$\begin{aligned}
 t_{rn} &= P \cdot R_n / (S_n \cdot E - 0,6 \cdot P) \\
 &= 28 \cdot 31,36 / (1,180 \cdot 1 - 0,6 \cdot 28) \\
 &= 0,75 \text{ mm}
 \end{aligned}$$

Required thickness t_r from UG-37(a)(c)

$$\begin{aligned}
 t_r &= P \cdot K_1 \cdot D_o / (2 \cdot S \cdot E + 0,8 \cdot P) \\
 &= 28 \cdot 0,9 \cdot 219,07 / (2 \cdot 1,180 \cdot 1 + 0,8 \cdot 28) \\
 &= 2,32 \text{ mm}
 \end{aligned}$$

Opening C is too close per UG-36(c)(3)(d) to allow an exemption per UG-36(c)(3)(a). Reinforcement calculations performed.

Area required per UG-37(c)

Allowable stresses: S_n = 1.203,265, S_v = 1.203,265 kg_f/cm²

$$f_{r1} = \text{lesser of } 1 \text{ or } S_n / S_v = 1$$

$$f_{r2} = \text{lesser of } 1 \text{ or } S_n / S_v = 1$$

$$\begin{aligned}
 A &= d \cdot t_r \cdot F + 2 \cdot t_n \cdot t_r \cdot F \cdot (1 - f_{r1}) \\
 &= (62,71 \cdot 2,32 \cdot 1 + 2 \cdot 5,16 \cdot 2,32 \cdot 1 \cdot (1 - 1)) / 100 \\
 &= [1,4532](#) \text{ cm}^2
 \end{aligned}$$

Area available from FIG. UG-37.1

$A_1 =$ larger of the following = 3.0355 cm²

$$\begin{aligned} &= d*(E_1*t - F*t_r) - 2*t_n*(E_1*t - F*t_r)*(1 - f_{r1}) \\ &= (62,71*(1*7,16 - 1*2,32) - 2*5,16*(1*7,16 - 1*2,32)*(1 - 1)) / 100 \\ &= 3,0355 \text{ cm}^2 \\ \\ &= 2*(t + t_n)*(E_1*t - F*t_r) - 2*t_n*(E_1*t - F*t_r)*(1 - f_{r1}) \\ &= (2*(7,16 + 5,16)*(1*7,16 - 1*2,32) - 2*5,16*(1*7,16 - 1*2,32)*(1 - 1)) / 100 \\ &= 1,1923 \text{ cm}^2 \end{aligned}$$

$A_2 =$ smaller of the following = 1.1348 cm²

$$\begin{aligned} &= 5*(t_n - t_{rn})*f_{r2}*t \\ &= (5*(5,16 - 0,75)*1*7,16) / 100 \\ &= 1,5755 \text{ cm}^2 \\ \\ &= 5*(t_n - t_{rn})*f_{r2}*t_n \\ &= (5*(5,16 - 0,75)*1*5,16) / 100 \\ &= 1,1348 \text{ cm}^2 \end{aligned}$$

$$\begin{aligned} A_{41} &= \text{Leg}^2*f_{r2} \\ &= (6^2*1) / 100 \\ &= \underline{0.36} \text{ cm}^2 \end{aligned}$$

$$\begin{aligned} \text{Area} &= A_1 + A_2 + A_{41} \\ &= 3,0355 + 1,1348 + 0,36 \\ &= \underline{4.5303} \text{ cm}^2 \end{aligned}$$

As Area \geq A the reinforcement is adequate.

UW-16(c) Weld Check

Fillet weld: t_{\min} = lesser of 19 mm or t_n or $t = 5,16$ mm

$t_{c(\min)}$ = lesser of 6 mm or $0,7*t_{\min} = \underline{3.61}$ mm

$t_{c(\text{actual})} = 0,7*\text{Leg} = 0.7*6 = 4,2$ mm

The fillet weld size is satisfactory.

Weld strength calculations are not required for this detail which conforms to Fig. UW-16.1, sketch (c-e).

UG-45 Nozzle Neck Thickness Check

$$\begin{aligned} t_{a \text{ UG-27}} &= P*R_n / (S_n*E - 0,6*P) + \text{Corrosion} \\ &= 28*31,36 / (1.180*1 - 0,6*28) + 0 \\ &= 0,75 \text{ mm} \end{aligned}$$

$$\begin{aligned} t_a &= \max[t_{a \text{ UG-27}} , t_{a \text{ UG-22}}] \\ &= \max[0,75 , 0] \\ &= 0,75 \text{ mm} \end{aligned}$$

$$t_{b1} = 2,32 \text{ mm}$$

$$\begin{aligned} t_{b1} &= \max[t_{b1} , t_{b \text{ UG16}}] \\ &= \max[2,32 , 1,5] \\ &= 2,32 \text{ mm} \end{aligned}$$

$$\begin{aligned} t_b &= \min[t_{b3} , t_{b1}] \\ &= \min[4,51 , 2,32] \\ &= 2,32 \text{ mm} \end{aligned}$$

$$\begin{aligned}t_{UG-45} &= \max[t_a , t_b] \\ &= \max[0,75 , 2,32] \\ &= \underline{2,32} \text{ mm}\end{aligned}$$

Available nozzle wall thickness new, $t_n = 0,875 \cdot 5,16 = 4,51$ mm

The nozzle neck thickness is adequate.

Oil Outlet (B)

ASME Section VIII Division 1, 2019 Edition Metric

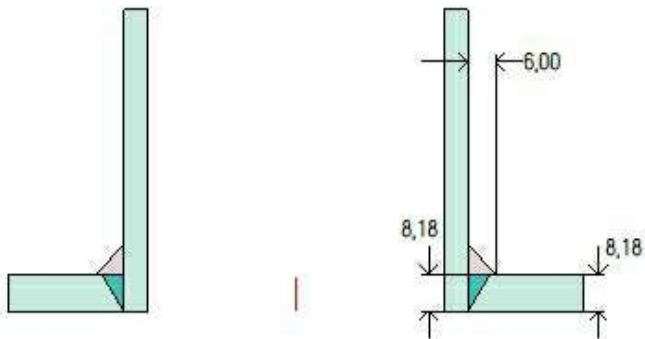

Note: round inside edges per UG-76(c)

Location and Orientation

Located on	Shell
Orientation	180°
Nozzle center line offset to datum line	96,32 mm
End of nozzle to shell center	345,54 mm
Passes through a Category A joint	No

Nozzle

Description	NPS 2,5 Sch 40 (Std) DN 65
Access opening	No
Material specification	SA-106 B Smls Pipe (II-D Metric p. 16, In. 10)
Inside diameter, new	62,71 mm
Pipe nominal wall thickness	5,16 mm
Pipe minimum wall thickness ¹	4,51 mm
Corrosion allowance	0 mm
Projection available outside vessel, L _{pr}	236 mm
Local vessel minimum thickness	7,16 mm
Liquid static head included	0 bar
Longitudinal joint efficiency	1

Welds

Inner fillet, Leg ₄₁	6 mm
Nozzle to vessel groove weld	8,18 mm

¹Pipe minimum thickness = nominal thickness times pipe tolerance factor of 0,875.

UCS-66 Material Toughness Requirements Nozzle

Impact test exempt per UCS-66(d) (NPS 4 or smaller pipe) =	-105°C
Material is exempt from impact testing at the Design MDMT of -29°C.	

Reinforcement Calculations for Internal Pressure

UG-37 Area Calculation Summary (cm ²)							UG-45 Summary (mm)	
For P = 28 bar @ 120 °C							The nozzle passes UG-45	
A required	A available	A ₁	A ₂	A ₃	A ₅	A welds	t _{req}	t _{min}
This nozzle is exempt from area calculations per UG-36(c)(3)(a)							2,58	4,51

UG-41 Weld Failure Path Analysis Summary
The nozzle is exempt from weld strength calculations per UW-15(b)(2)

UW-16 Weld Sizing Summary			
Weld description	Required weld throat size (mm)	Actual weld throat size (mm)	Status
Nozzle to shell fillet (Leg ₄₁)	3,61	4,2	weld size is adequate

Calculations for internal pressure 28 bar @ 120 °C

Parallel Limit of reinforcement per UG-40

$$\begin{aligned}
 L_R &= \text{MAX}(d, R_n + (t_n - C_n) + (t - C)) \\
 &= \text{MAX}(62,71, 31,36 + (5,16 - 0) + (7,16 - 0)) \\
 &= 62,71 \text{ mm}
 \end{aligned}$$

Outer Normal Limit of reinforcement per UG-40

$$\begin{aligned}
 L_H &= \text{MIN}(2,5*(t - C), 2,5*(t_n - C_n) + t_e) \\
 &= \text{MIN}(2,5*(7,16 - 0), 2,5*(5,16 - 0) + 0) \\
 &= 12,89 \text{ mm}
 \end{aligned}$$

Nozzle required thickness per UG-27(c)(1)

$$\begin{aligned}
 t_{rn} &= P * R_n / (S_n * E - 0,6 * P) \\
 &= 28 * 31,36 / (1.180 * 1 - 0,6 * 28) \\
 &= 0,75 \text{ mm}
 \end{aligned}$$

Required thickness t_r from UG-37(a)

$$\begin{aligned}
 t_r &= P * R_o / (S * E + 0,4 * P) \\
 &= 28 * 109,54 / (1.180 * 1 + 0,4 * 28) \\
 &= 2,57 \text{ mm}
 \end{aligned}$$

This opening does not require reinforcement per UG-36(c)(3)(a)

UW-16(c) Weld Check

Fillet weld: t_{min} = lesser of 19 mm or t_n or t = 5,16 mm

t_{c(min)} = lesser of 6 mm or 0,7*t_{min} = 3,61 mm

t_{c(actual)} = 0,7*Leg = 0,7*6 = 4,2 mm

The fillet weld size is satisfactory.

Weld strength calculations are not required for this detail which conforms to Fig. UW-16.1, sketch (c-e).

UG-45 Nozzle Neck Thickness Check

$$\begin{aligned}
 t_{a \text{UG-27}} &= P \cdot R_n / (S_n \cdot E - 0,6 \cdot P) + \text{Corrosion} \\
 &= 28 \cdot 31,36 / (1.180 \cdot 1 - 0,6 \cdot 28) + 0 \\
 &= 0,75 \text{ mm}
 \end{aligned}$$

$$\begin{aligned}
 t_a &= \max[t_{a \text{UG-27}} , t_{a \text{UG-22}}] \\
 &= \max[0,75 , 0] \\
 &= 0,75 \text{ mm}
 \end{aligned}$$

$$\begin{aligned}
 t_{b1} &= P \cdot R_o / (S \cdot E + 0,4 \cdot P) + \text{Corrosion} \\
 &= 28 \cdot 109,54 / (1.180 \cdot 1 + 0,4 \cdot 28) + 0 \\
 &= 2,58 \text{ mm}
 \end{aligned}$$

$$\begin{aligned}
 t_{b1} &= \max[t_{b1} , t_{b \text{UG16}}] \\
 &= \max[2,58 , 1,5] \\
 &= 2,58 \text{ mm}
 \end{aligned}$$

$$\begin{aligned}
 t_b &= \min[t_{b3} , t_{b1}] \\
 &= \min[4,51 , 2,58] \\
 &= 2,58 \text{ mm}
 \end{aligned}$$

$$\begin{aligned}
 t_{\text{UG-45}} &= \max[t_a , t_b] \\
 &= \max[0,75 , 2,58] \\
 &= \underline{2,58} \text{ mm}
 \end{aligned}$$

Available nozzle wall thickness new, $t_n = 0,875 \cdot 5,16 = 4,51 \text{ mm}$

The nozzle neck thickness is adequate.

Vent/Relief (C)

ASME Section VIII Division 1, 2019 Edition Metric

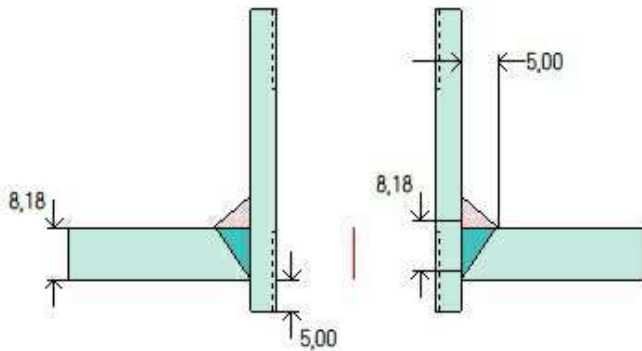

Note: round inside edges per UG-76(c)

Location and Orientation

Located on	B16.9 Pipe Cap
Orientation	180°
End of nozzle to datum line	1.369,78 mm
Calculated as hillside	No
Distance to head center, R	86 mm
Passes through a Category A joint	No

Nozzle

Description	NPS 0,5 Class 3000 DN 15 - Threaded Full Coupling (47,75 mm length)
Access opening	No
Material specification	SA-105 (II-D Metric p. 20, In. 19)
Inside diameter, new	21,34 mm
Nominal wall thickness	3,56 mm
Corrosion allowance	0 mm
Projection available outside vessel, L_{pr}	34,31 mm
Internal projection, h_{new}	5 mm
Local vessel minimum thickness	7,16 mm
Liquid static head included	0 bar
Longitudinal joint efficiency	1

Welds

Inner fillet, Leg_{41}	5 mm
Lower fillet, Leg_{43}	0 mm
Nozzle to vessel groove weld	8,18 mm

UCS-66 Material Toughness Requirements Nozzle

$t_r = 28 \cdot 10,67 / (1.380 \cdot 1 - 0,6 \cdot 28) =$	0,22 mm
Stress ratio = $t_r \cdot E^* / (t_n - c) = 0,22 \cdot 1 / (3,56 - 0) =$	0,0616
Stress ratio $\leq 0,35$, MDMT per UCS-66(b)(3) =	-105°C
Material is exempt from impact testing at the Design MDMT of -29°C.	

Reinforcement Calculations for Internal Pressure

UG-37 Area Calculation Summary (cm ²)							UG-44 Summary (mm)	
For P = 28 bar @ 120 °C							The nozzle passes UG-44	
A required	A available	A ₁	A ₂	A ₃	A ₅	A welds	t _{req}	t _{min}
This nozzle is exempt from area calculations per UG-36(c)(3)(a)							1,5	3,56

UG-41 Weld Failure Path Analysis Summary
The nozzle is exempt from weld strength calculations per UW-15(b)(2)

UW-16 Weld Sizing Summary			
Weld description	Required weld throat size (mm)	Actual weld throat size (mm)	Status
Nozzle to shell fillet (Leg ₄₁)	2,49	3,5	weld size is adequate

Calculations for internal pressure 28 bar @ 120 °C

Parallel Limit of reinforcement per UG-40

$$\begin{aligned}
 L_R &= \text{MAX}(d, R_n + (t_n - C_n) + (t - C)) \\
 &= \text{MAX}(21,34, 10,67 + (3,56 - 0) + (7,16 - 0)) \\
 &= 21,38 \text{ mm}
 \end{aligned}$$

Outer Normal Limit of reinforcement per UG-40

$$\begin{aligned}
 L_H &= \text{MIN}(2,5*(t - C), 2,5*(t_n - C_n) + t_e) \\
 &= \text{MIN}(2,5*(7,16 - 0), 2,5*(3,56 - 0) + 0) \\
 &= 8,89 \text{ mm}
 \end{aligned}$$

Inner Normal Limit of reinforcement per UG-40

$$\begin{aligned}
 L_I &= \text{MIN}(h, 2,5*(t - C), 2,5*(t_i - C_n - C)) \\
 &= \text{MIN}(5, 2,5*(7,16 - 0), 2,5*(3,56 - 0 - 0)) \\
 &= 5 \text{ mm}
 \end{aligned}$$

Nozzle required thickness per UG-27(c)(1)

$$\begin{aligned}
 t_{rn} &= P \cdot R_n / (S_n \cdot E - 0,6 \cdot P) \\
 &= 28 \cdot 10,67 / (1,380 \cdot 1 - 0,6 \cdot 28) \\
 &= 0,22 \text{ mm}
 \end{aligned}$$

Required thickness t_r from UG-37(a)

$$\begin{aligned}
 t_r &= P \cdot D_o \cdot K / (2 \cdot S \cdot E + 2 \cdot P \cdot (K - 0,1)) \\
 &= 28 \cdot 219,07 \cdot 1 / (2 \cdot 1,180 \cdot 1 + 2 \cdot 28 \cdot (1 - 0,1)) \\
 &= 2,54 \text{ mm}
 \end{aligned}$$

This opening does not require reinforcement per UG-36(c)(3)(a)

UW-16(c) Weld Check

Fillet weld: t_{min} = lesser of 19 mm or t_n or t = 3,56 mm

t_{c(min)} = lesser of 2,5 mm or 0,7*t_{min} = 2,49 mm

t_{c(actual)} = 0,7*Leg = 0,7*5 = 3,5 mm

The fillet weld size is satisfactory.

Weld strength calculations are not required for this detail which conforms to Fig. UW-16.1, sketch (c-e).

UG-44 Thickness Check - ASME B16.11 Coupling

$$\begin{aligned}t_{a \text{ App 1-1}} &= P \cdot R_o / (S_n \cdot E + 0,4 \cdot P) + \text{Corrosion} \\ &= 28 \cdot 14,22 / (1.380 \cdot 1 + 0,4 \cdot 28) + 0 \\ &= 0,29 \text{ mm}\end{aligned}$$

$$\begin{aligned}t_{a \text{ UG-44}} &= \max[t_{a \text{ App 1-1}} , t_b \text{ UG16}] \\ &= \max[0,29 , 1,5] \\ &= \underline{1,5} \text{ mm}\end{aligned}$$

Available nozzle wall thickness new, $t_n = 3,56 \text{ mm}$

The nozzle neck thickness is adequate.

Vent/Relief (C)

ASME Section VIII Division 1, 2019 Edition Metric

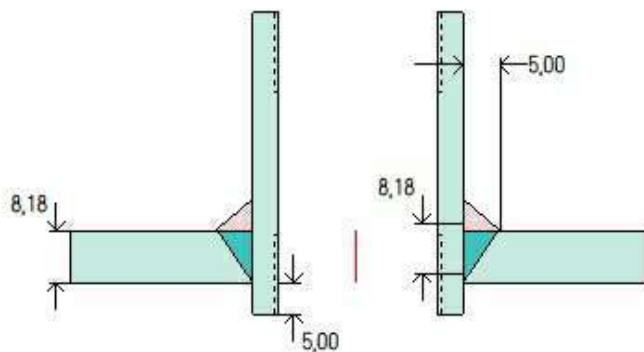

Note: round inside edges per UG-76(c)

Location and Orientation

Located on	B16.9 Pipe Cap
Orientation	0°
End of nozzle to datum line	1.369,78 mm
Calculated as hillside	No
Distance to head center, R	86 mm
Passes through a Category A joint	No

Nozzle

Description	NPS 0,5 Class 3000 DN 15 - Threaded Full Coupling
Access opening	No
Material specification	SA-105 (II-D Metric p. 20, In. 19)
Inside diameter, new	21,34 mm
Nominal wall thickness	3,56 mm
Corrosion allowance	0 mm
Projection available outside vessel, L _{pr}	34,31 mm
Internal projection, h _{new}	5 mm
Local vessel minimum thickness	7,16 mm
Liquid static head included	0 bar
Longitudinal joint efficiency	1

Welds

Inner fillet, Leg ₄₁	5 mm
Lower fillet, Leg ₄₃	0 mm
Nozzle to vessel groove weld	8,18 mm

UCS-66 Material Toughness Requirements Nozzle

$t_r = 28 \cdot 10,67 / (1.380 \cdot 1 - 0,6 \cdot 28) =$	0,22 mm
Stress ratio = $t_r \cdot E^* / (t_n - c) = 0,22 \cdot 1 / (3,56 - 0) =$	0,0616
Stress ratio $\leq 0,35$, MDMT per UCS-66(b)(3) =	-105°C
Material is exempt from impact testing at the Design MDMT of -29°C.	

Reinforcement Calculations for Internal Pressure

UG-37 Area Calculation Summary (cm ²)							UG-44 Summary (mm)	
For P = 28 bar @ 120 °C							The nozzle passes UG-44	
A required	A available	A ₁	A ₂	A ₃	A ₅	A welds	t _{req}	t _{min}
This nozzle is exempt from area calculations per UG-36(c)(3)(a)							1,5	3,56

UG-41 Weld Failure Path Analysis Summary
The nozzle is exempt from weld strength calculations per UW-15(b)(2)

UW-16 Weld Sizing Summary			
Weld description	Required weld throat size (mm)	Actual weld throat size (mm)	Status
Nozzle to shell fillet (Leg ₄₁)	2,49	3,5	weld size is adequate

Calculations for internal pressure 28 bar @ 120 °C

Parallel Limit of reinforcement per UG-40

$$\begin{aligned}
 L_R &= \text{MAX}(d, R_n + (t_n - C_n) + (t - C)) \\
 &= \text{MAX}(21,34, 10,67 + (3,56 - 0) + (7,16 - 0)) \\
 &= 21,38 \text{ mm}
 \end{aligned}$$

Outer Normal Limit of reinforcement per UG-40

$$\begin{aligned}
 L_H &= \text{MIN}(2,5*(t - C), 2,5*(t_n - C_n) + t_e) \\
 &= \text{MIN}(2,5*(7,16 - 0), 2,5*(3,56 - 0) + 0) \\
 &= 8,89 \text{ mm}
 \end{aligned}$$

Inner Normal Limit of reinforcement per UG-40

$$\begin{aligned}
 L_I &= \text{MIN}(h, 2,5*(t - C), 2,5*(t_i - C_n - C)) \\
 &= \text{MIN}(5, 2,5*(7,16 - 0), 2,5*(3,56 - 0 - 0)) \\
 &= 5 \text{ mm}
 \end{aligned}$$

Nozzle required thickness per UG-27(c)(1)

$$\begin{aligned}
 t_{rn} &= P \cdot R_n / (S_n \cdot E - 0,6 \cdot P) \\
 &= 28 \cdot 10,67 / (1,380 \cdot 1 - 0,6 \cdot 28) \\
 &= 0,22 \text{ mm}
 \end{aligned}$$

Required thickness t_r from UG-37(a)

$$\begin{aligned}
 t_r &= P \cdot D_o \cdot K / (2 \cdot S \cdot E + 2 \cdot P \cdot (K - 0,1)) \\
 &= 28 \cdot 219,07 \cdot 1 / (2 \cdot 1,180 \cdot 1 + 2 \cdot 28 \cdot (1 - 0,1)) \\
 &= 2,54 \text{ mm}
 \end{aligned}$$

This opening does not require reinforcement per UG-36(c)(3)(a)

UW-16(c) Weld Check

Fillet weld: t_{min} = lesser of 19 mm or t_n or t = 3,56 mm

t_{c(min)} = lesser of 2,5 mm or 0,7*t_{min} = 2,49 mm

t_{c(actual)} = 0,7*Leg = 0,7*5 = 3,5 mm

The fillet weld size is satisfactory.

Weld strength calculations are not required for this detail which conforms to Fig. UW-16.1, sketch (c-e).

UG-44 Thickness Check - ASME B16.11 Coupling

$$\begin{aligned}t_{a \text{ App 1-1}} &= P \cdot R_o / (S_n \cdot E + 0,4 \cdot P) + \text{Corrosion} \\ &= 28 \cdot 14,22 / (1.380 \cdot 1 + 0,4 \cdot 28) + 0 \\ &= 0,29 \text{ mm}\end{aligned}$$

$$\begin{aligned}t_{a \text{ UG-44}} &= \max[t_{a \text{ App 1-1}} , t_{b \text{ UG16}}] \\ &= \max[0,29 , 1,5] \\ &= \underline{1,5} \text{ mm}\end{aligned}$$

Available nozzle wall thickness new, $t_n = 3,56 \text{ mm}$

The nozzle neck thickness is adequate.



2) DESENHOS DE EQUIPAMENTOS E PLAQUETAS
DRAWINGS AND PLATES

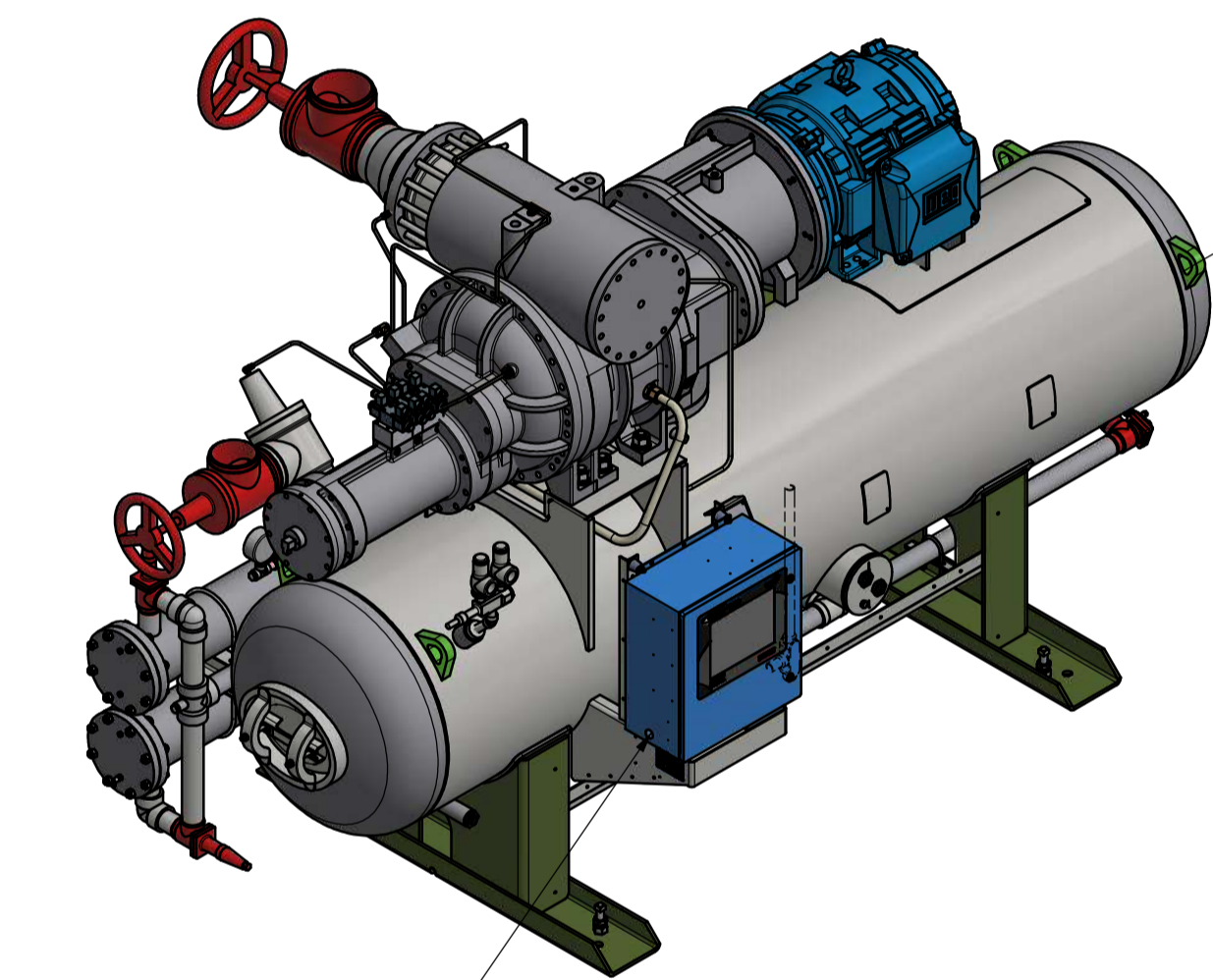
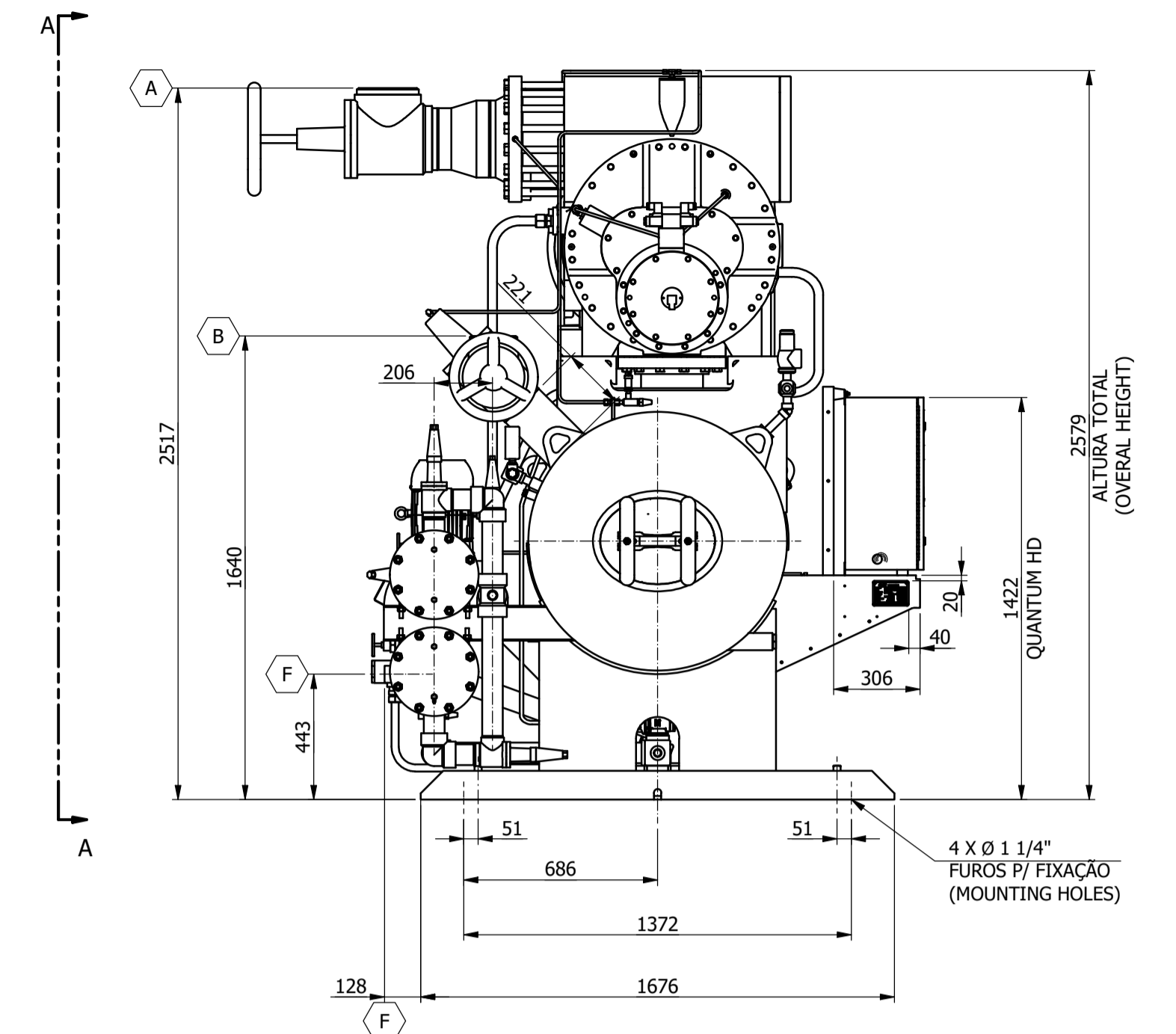
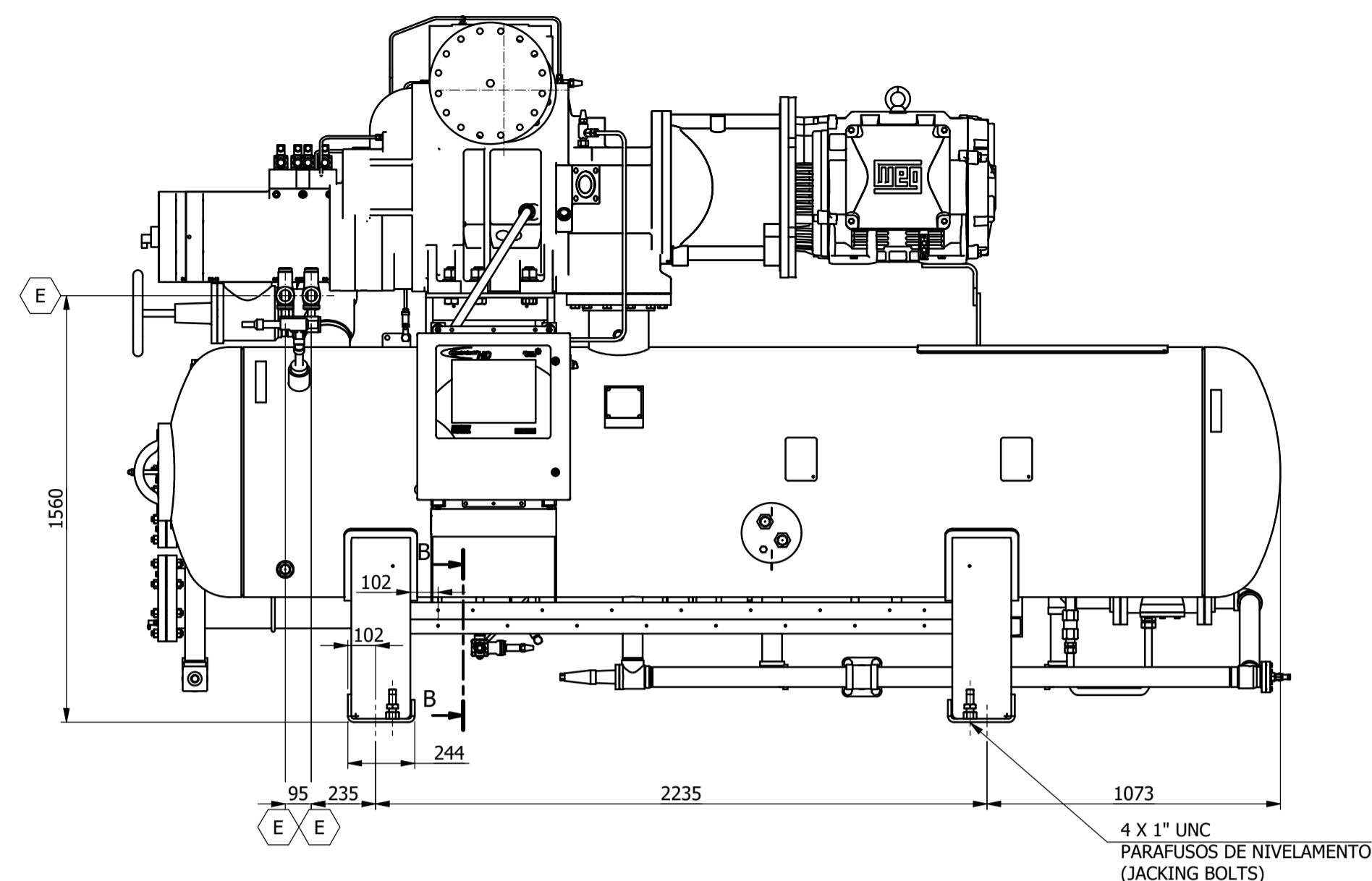
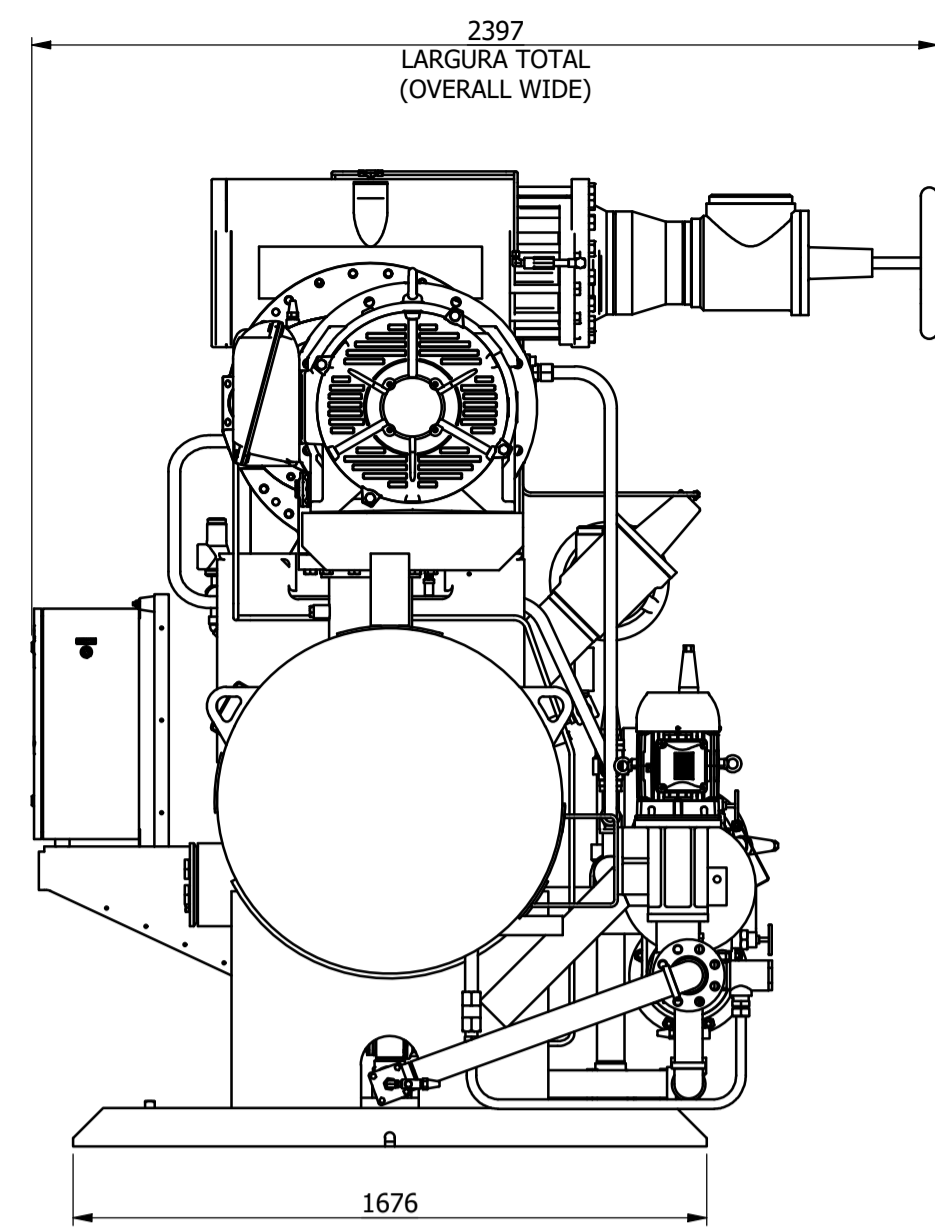

ÓLHAL DE IÇAMENTO (LIFTING EYE)

PLAQUETA DE IDENTIFICAÇÃO DA UNIDADE COMPRESSORA (COMPRESSOR UNITY NAME PLATE)

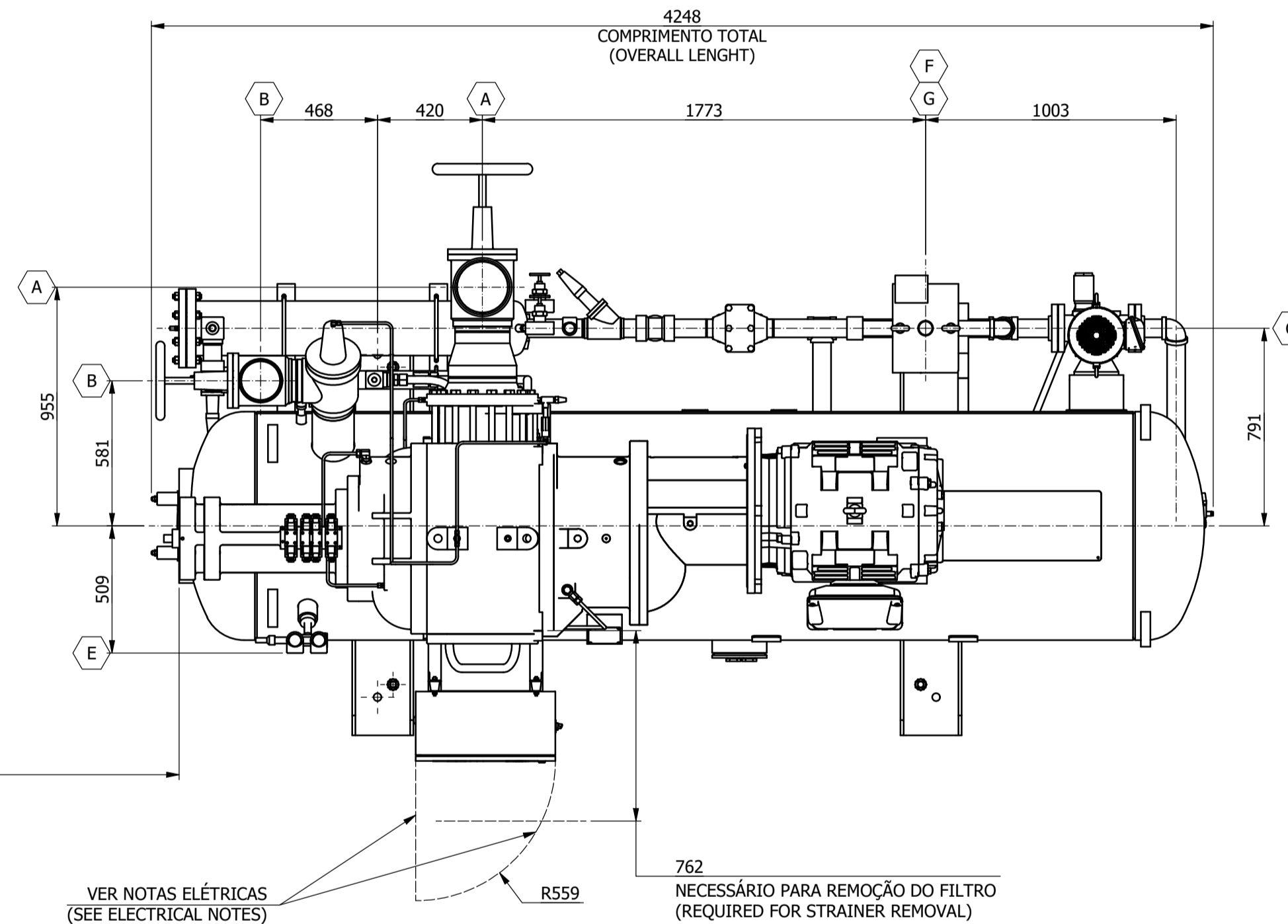

914 REQUERIDO PARA REMOÇÃO DOS COALESCEDORES E DO SLIDE VALVE (REQUIRED FOR COALESCERS AND SLIDE VALVE REMOVAL)

VER NOTAS ELÉTRICAS (SEE ELECTRICAL NOTES)

762 NECESSÁRIO PARA REMOÇÃO DO FILTRO (REQUIRED FOR STRAINER REMOVAL)

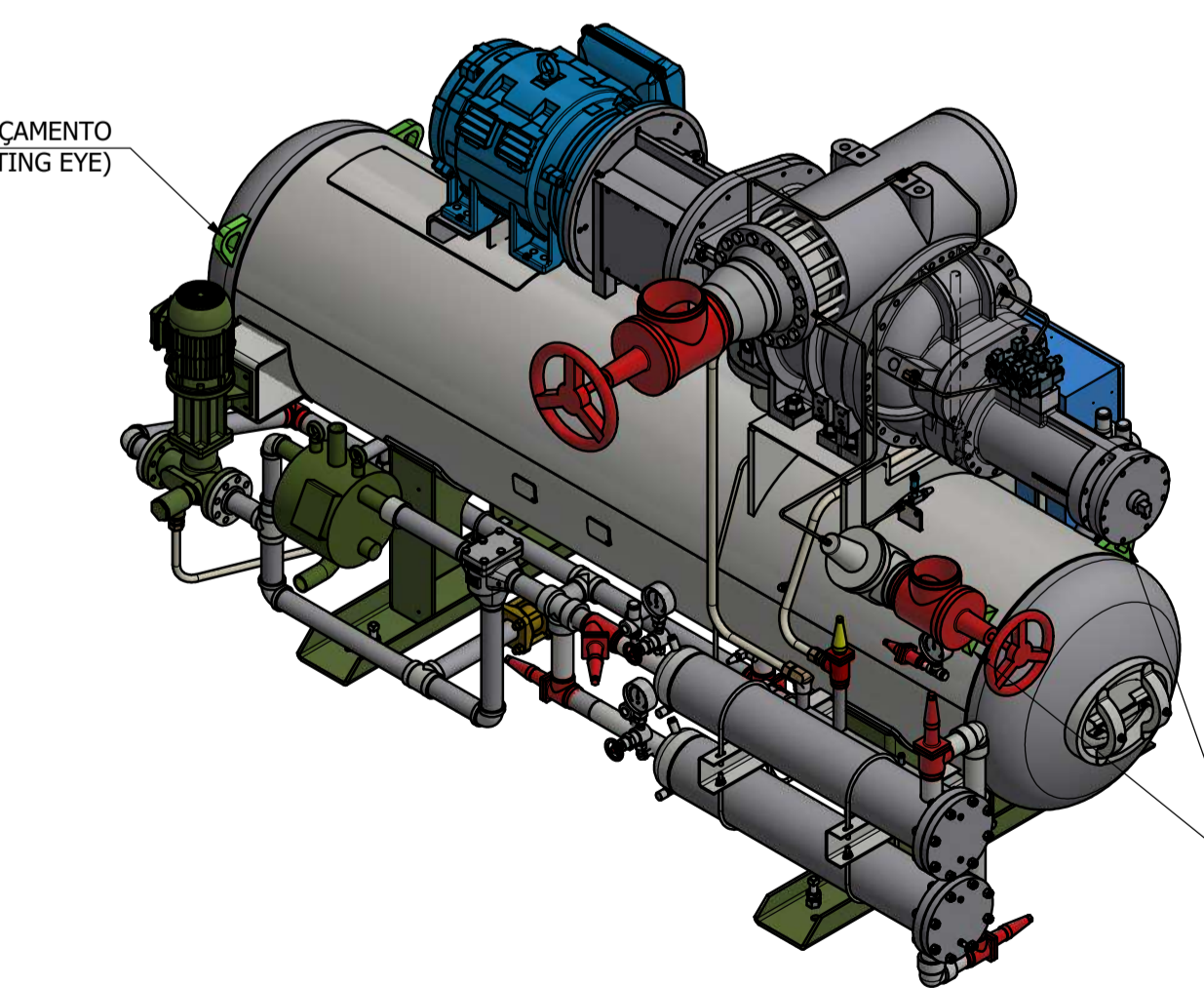

ÓLHAL DE IÇAMENTO (LIFTING EYE)

ÓLHAIS DE IÇAMENTO (LIFTING EYES)

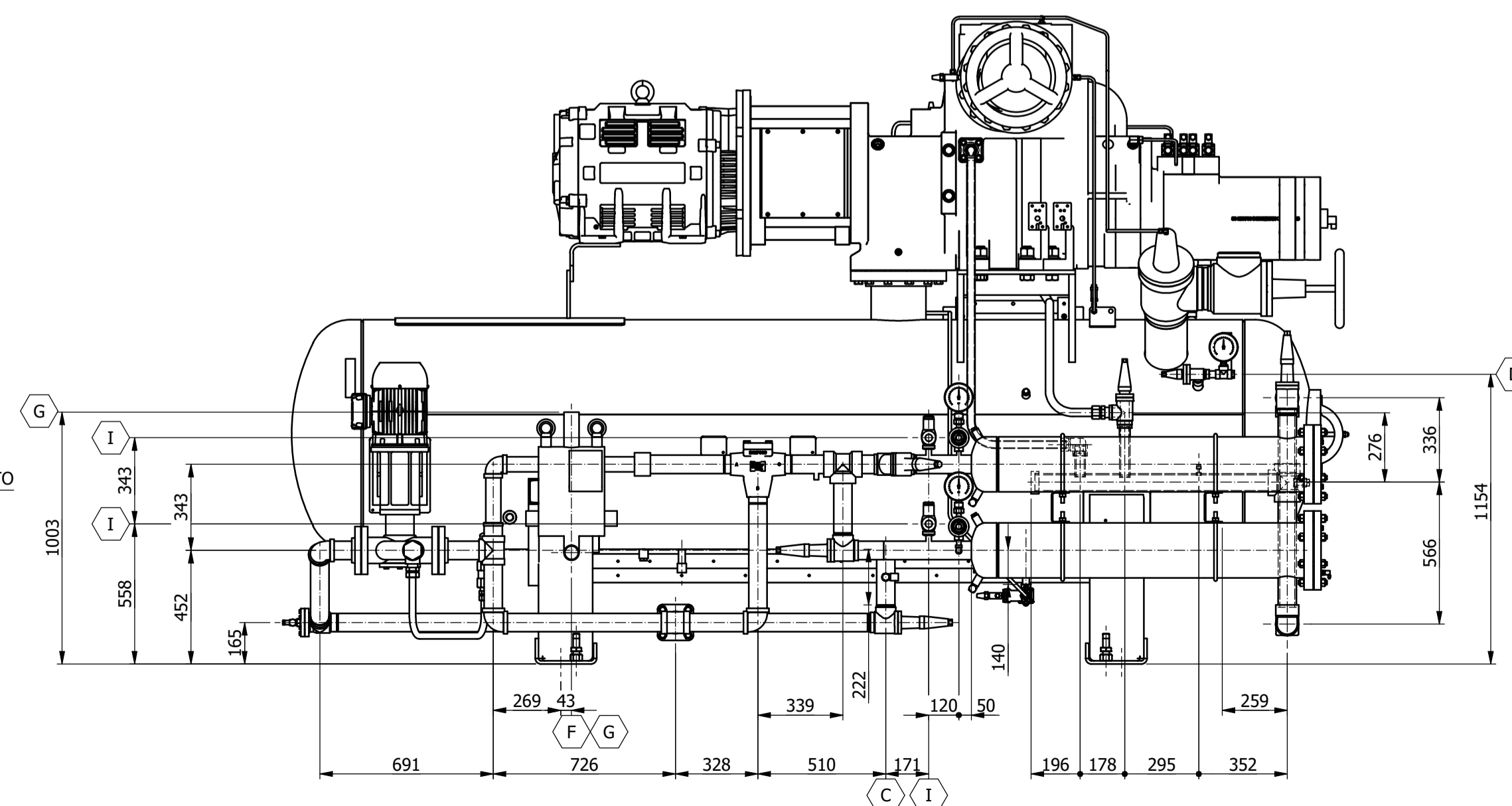

VISTA A ESC.: (1:20)

EN.: CUSTOMER NOTES:

MECHANICAL

- OTHERWISE INDICATED, ALL DIMENSIONS ARE IN MILLIMETERS.
- NOTICE TO INSTALLER TO ALLOW ADJUSTMENT IN EACH PLANE FOR EXTERNALLY PREFABRICATED PIPING.
- THIS COMPRESSOR PACKAGE MUST BE ANCHORED, SHIMMED AND GROUTED TO A SUITABLE FOUNDATION IN ACCORDANCE WITH JCI DOCUMENT S70-2101B, SCREW COMPRESSOR FOUNDATIONS.
- MUST LEAVE HAND THROTTLING VALVE, ON MAIN OIL INJECTION LINE, FULLY OPEN AT INSTALLATION AND START UP.
- UNLESS OTHERWISE SPECIFIED ALL DIMENSIONS ARE CONSIDERED REFERENCE.
- COMPRESSOR DRIVE COUPLING MUST BE INSTALLED WITH KEYWAYS 180° APART.

ELECTRICAL

- THE DIMENSIONS SHOWN FOR THE DOOR SWING ON THE ELECTRICAL PANELS DO NOT STIPULATE THE REQUIRED CLEARANCE FOR COMPLIANCE WITH THE NATIONAL ELECTRIC CODE (NEC) OR ANY LOCAL CODES.
- IF POWER SUPPLY CONDUIT RUN FROM CEILING, INSTALL LOW POINT ELECTRICAL DRAIN TO PREVENT CONDENSATION FROM ENTERING ELECTRICAL PANEL.
- AVOID DRILLING AND CUTTING IN THE CONTROLLER AND STARTER ENCLOSURE TOP.
- CONTROL WIRING BY JCI AND POWER WIRING BY OTHERS.
- REFER TO STARTER/DRIVE OPERATOR'S GUIDE AND INSTRUCTION MANUAL FOR CIRCUIT BREAKER/FUSE SIZING.

PT.: NOTAS P/ CLIENTE

MECÂNICA:

- TODAS AS DIMENSÕES ESTÃO EM MILÍMETROS, EXCETO ONDE INDICADO.
- AVISO AO INSTALADOR, CASO SEJA UTILIZADO UMA TUBULAÇÃO PRÉ-FABRICADA É NECESSÁRIO QUE ELA PERMITA AJUSTE DE CAMPO EM TODOS OS EIXOS.
- ESTA UNIDADE COMPRESSORA DEVERÁ SER NIVELADA, FIXADA E GRAUTEADA EM UMA BASE CIVIL CONFORME DOCUMENTO JCI S70-2101B, FUNDAÇÕES PARA COMPRESSORES PARAFUSO
- DEIXAR A VÁLVULA DE REGULAGEM DE PRESSÃO DE ÓLEO TOTALMENTE ABERTA APÓS INSTALAÇÃO E STARTUP.
- A MENOS QUE DE OUTRA FORMA ESPECIFICADO, TODAS AS DIMENSÕES SÃO CONSIDERADAS REFERÊNCIA.
- AS CHAVETAS DOS CUBOS DOS ACOPLAMENTO DEVEEM SER INSTALADAS OPOSTAS 180° UMA DA OUTRA.

ELÉTRICA:

- AS DIMENSÕES MOSTRADAS PARA ABERTURA DAS PORTAS DOS PAINÉIS ELÉTRICOS E CONTROLADOR SÃO AS MÍNIMAS PARA ABERTURAS DOS MESMOS E NÃO ESTIPULAM O ESPAÇO NECESSÁRIO PARA O CUMPRIMENTO DO CÓDIGO ELÉTRICO NACIONAL (NEC) OU DE QUALQUER OUTRO CÓDIGO LOCAL.
- SE O ENCAMINHAMENTO DO ELETRODUTO DE ALIMENTAÇÃO DO PAINEL/CONTROLADOR FOR A PARTIR DO TETO, INSTALAR UM DRENO PARA PREVENIR ENTRADA DE ÁGUA CONDENSADA NO PAINEL ELÉTRICO.
- EVITE A PERFURAÇÃO NO TOPO DO CONTROLADOR E PAINÉIS ELÉTRICOS.
- CABEAMENTO DE COMANDO É ESCOPO JCI E CABEAMENTO DE FORÇA POR OUTROS.
- CONSULTE O MANUAL DE INSTRUÇÕES/OPERAÇÃO DO DRIVER DO PAINEL PARA DIMENSIONAMENTO DOS DISJUNTORES/FUSÍVEIS

NOTAS PARA FABRICAÇÃO:

- BLOCO COMPRESSOR SGC 2817
- SEPARADOR DE ÓLEO HOS-36
- ISOLAR PARA TESTE OS TRANSDUTORES E AS VÁLVULAS DE SEGURANÇA.
- PRESSÃO DE TESTE DA UNIDADE APÓS MONTAGEM 21 bar PNEUMÁTICO.
- PROTEGER O CONTROLADOR E AS VÁLVULAS DE SEGURANÇA PARA TRANSPORTE.
- DESENHO DO FLUXOGRAMA: 5415CF399-032

DADOS TÉCNICOS (TECNICAL DATA):

- MOTOR: 220kW (300HP), FS(SF) 1.15, 3550RPM, 380V, 60HZ, IP-23, 2805/M, IE-3
- PESO DE TRANSPORTE APROXIMADO (APPROXIMATED SHIPPING WEIGHT): 5818kg
- PESO DE OPERAÇÃO APROXIMADO (APPROXIMATED OPERATING WEIGHT): 6239kg
- VOLUME DE ÓLEO APROXIMADO (APPROXIMATED OIL VOLUME): 492 L

LISTA DE CONEXÕES (CONNECTION LEGEND)

Con (Conn)	Qty	Diâmetro (Size)	Sch. / Esp.	Classe (Class)	Descrição (Description)
A	1	8	40		SUCCÃO (SUCTION)
B	1	6	40		DESCARGA (DISCHARGE)
C	1	1/2		3000 NPT	CARGA/DRENO DE ÓLEO (OIL CHARGE/DRAIN)
D	2	3/4		3000 NPT	CARGA/DESCARGA DE FLUÍDO REFRIGERANTE (PUMP OUT)
E	2	1 1/4		R. NPT(F)	VÁLVULA DE SEGURANÇA (SAFETY VALVE)
F	1	2	40		ENTRADA DE LÍQUIDO REFRIGERANTE NO RESFR. ÓLEO (OIL COOLING LIQUID REFR. INLET)
G	1	2	40		SAÍDA DE VAPOR DE REFRIGERANTE DO RESFR. ÓLEO (OIL COOLING REFR. VAPOR OUTLET)
I	2	1		R. NPT(F)	VÁLVULA DE SEGURANÇA (SAFETY VALVE)

QUADR.	REV.	ECV/NAE	EMISSÃO INICIAL	LMR	05/08/2021	FAR	05/08/2021	AA	05/08/2021
			DESCRIÇÃO DA REVISÃO	DES.	DATA DES.	VER.	DATA VER.	APR.	DATA APR.
HISTÓRICO DE REVISÕES									
CLIENTE: MARFRIG BATAGUASSU			TÍTULO: UNIDADE COMPRESSORA (COMPRESSOR UNIT) RWF 399						
Nº PEDIDO: 32107D.026			TERMOFISÃO (TSOC) / QUANTUM HD						
FORMATO: A1			ARRANJO GERAL (GENERAL ARRANGEMENT)						
SUBSTITUI DESENHO:									
ACABAMENTO E TOLERÂNCIA CONF.: 17-00.213-BE-BR			DES. Nº.: 4847CF399-032						
			REV.: 0						
			FOLHA Nº. 1 / 1						

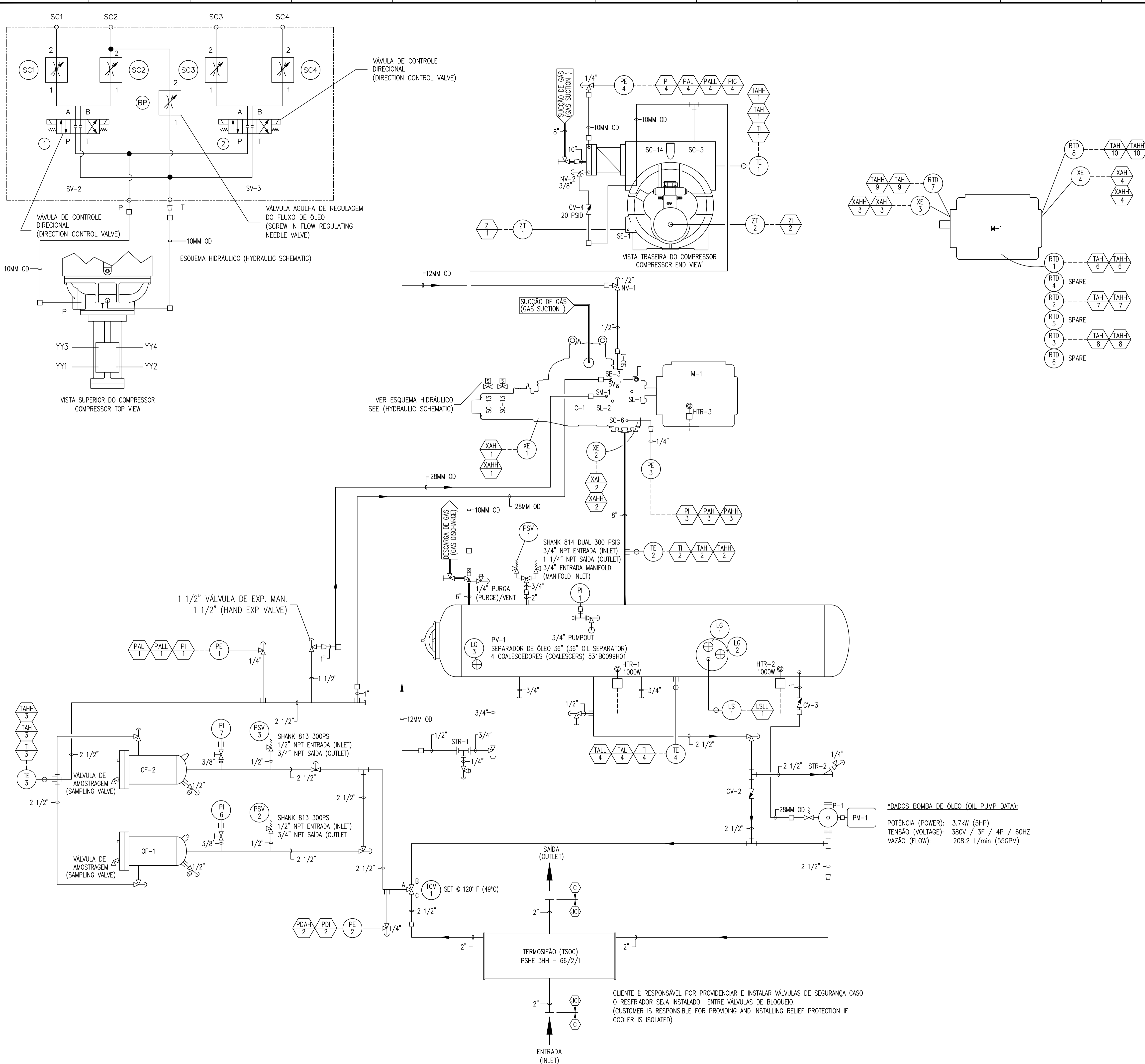

CONEXÃO	(TAMANHO)	DESCRIÇÃO (DESCRIPTION)
P	9/16-18UNF-2B	FORNECIMENTO DE PRESSÃO (PRESSURE SUPPLY)
T	9/16-18UNF-2B	ALÍVIO PARA O RESERVATÓRIO (RELIEF TO TANK)
SC-1	5/16	VÁLVULA AGULHA DE REGULAGEM DO FLUXO DE ÓLEO (SCREW IN FLOW REGULATING NEEDLE VALVE)
SC-2	5/16	VÁLVULA AGULHA DE REGULAGEM DO FLUXO DE ÓLEO (SCREW IN FLOW REGULATING NEEDLE VALVE)
SC-3	5/16	VÁLVULA AGULHA DE REGULAGEM DO FLUXO DE ÓLEO (SCREW IN FLOW REGULATING NEEDLE VALVE)
SC-4	5/16	VÁLVULA AGULHA DE REGULAGEM DO FLUXO DE ÓLEO (SCREW IN FLOW REGULATING NEEDLE VALVE)

LEGENDA (LEGEND)			
AS	AIR SUPPLY	PE	PRESSURE TRANSDUCER
C	COMPRESSOR	PI	PRESSURE INDICATOR
CV	CHECK VALVE	PIC	PRESSURE INDICATING CONTROLLER
FG	FLOW GLASS	PM	PUMP MOTOR
FS	FLOW SWITCH	PSV	PRESSURE SAFETY VALVE
GCOC	GLYCOL COOLED OIL COOLER	PV	PRESSURE VESSEL
HTR	HEATER	RTD	RESISTANCE TEMPERATURE DETECTOR
HV	HAND VALVE	STR	STRAINER
HX	HEAT EXCHANGER	TAH	HIGH TEMPERATURE ALARM
LG	LEVEL GLASS	TAHH	HIGH TEMPERATURE SHUTDOWN
LIC	LEVEL INDICATING CONTROLLER	TAL	LOW TEMPERATURE ALARM
LS	LEVEL SWITCH	TALL	LOW TEMPERATURE SHUTDOWN
LSL	LOW LEVEL SWITCH (ALARM)	TCV	TEMPERATURE CONTROL VALVE
LSLL	LOW LEVEL SWITCH (SHUTDOWN)	TE	TEMPERATURE ELEMENT
LSH	HIGH LEVEL SWITCH (ALARM)	TI	TEMPERATURE INDICATOR
LSHH	HIGH LEVEL SWITCH (SHUTDOWN)	TS	TEMPERATURE SWITCH
M	MOTOR	TSOC	THERMOSYPHON OIL COOLER
MV	MOTOR OPERATED VALVE	TT	TEMPERATURE TRANSMITTER
NV	NEEDLE VALVE	VI	VI CONTROL
OF	OIL FILTER	WCOC	WATER COOLED OIL COOLER
P	PUMP	WS	WATER SUPPLY
PAH	HIGH PRESSURE ALARM	XAH	HIGH VIBRATION ALARM
PAHH	HIGH PRESSURE SHUTDOWN	XAHH	HIGH VIBRATION SHUTDOWN
PAL	LOW PRESSURE ALARM	XE	VIBRATION ELEMENT
PALL	LOW PRESSURE SHUTDOWN	XT	VIBRATION TRANSMITTER
PCV	PRESSURE CONTROL VALVE	YY	SOLENOID VALVE
PDI	PRESSURE DIFFERENTIAL INDICATOR	ZI	POSITION INDICATOR
PDH	HIGH PRESSURE DIFFERENTIAL ALARM	ZT	POSITION TRANSMITTER
PDHH	HIGH PRESSURE DIFFERENTIAL SHUTDOWN	ZV	POSITION VALVE

CONEXÃO	SIZE (TAMANHO)	DESCRIÇÃO (DESCRIPTION)
SB-2	1 1/16-12UN-2B	PISTÃO DE BALANCEAMENTO E ROLAMENTOS DA SUÇÃO (BALANCE PISTON & INLET BEARINGS)
SB-3	1 1/4 SQ. FLG.	INJEÇÃO PRINCIPAL DE ÓLEO (MAIN OIL SUPPLY)
SC-5	9/16-18UNF-2B	PRESSÃO DE SUÇÃO (INLET PRESSURE)
SC-6	9/16-18UNF-2B	PRESSÃO DE DESCARGA (DISCHARGE PRESSURE)
SC-7	1/8 - 27 NPTF	DRENO DO SELO (SEAL WEEPAGE)
SC-8	1 5/16-12UN-2B	DRENO (CLOSED THREAD DRAIN)
SC-9	9/16-18UNF-2B	DRENO (INLET HOUSING OIL DRAIN)
SC-13	9/16-18UNF-2B	DRENO DE ÓLEO DO CILINDRO (OIL DRAIN CYLINDER)
SM-1	1 5/8-12UN-2B	INJEÇÃO PRINCIPAL DE ÓLEO (MAIN OIL INJECTION)
SV-1	2 1/2 SQ. FLG.	INJEÇÃO DE VAPOR (VAPOR INJECTION TONGUE & GROOVE)
SE-1	1/2" - 14 NPTF	CONECTOR ELÉTRICO (ELECTRICAL CONNECTOR)
SD-1	1 1/16-12UN-2B	RETORNO DO COALESCEADOR (COALESCER BLEED LINE)
SC-14	9/16-18UNF-2B	RETORNO DA INJEÇÃO DE LÍQUIDO (LIQUID INJECTION BLEED)
SL-1	1 5/16-12UN-2B	INJEÇÃO DE LÍQUIDO LOW VI (LOW VI LIQUID INJECTION)
SL-2	1 5/16-12UN-2B	INJEÇÃO DE LÍQUIDO HIGH VI (HIGH VI LIQUID INJECTION)
TE-1	3/4"-14 NPTF	TERMOMENTO SUÇÃO DE GÁS (SUCTION GAS TEMPERATURE ELEMENT)
P	1 1/16-12UN-2B	FORNECIMENTO DE PRESSÃO (PRESSURE SUPPLY)
T	3/4-16UNF-2B	ALÍVIO PARA O RESERVATÓRIO (RELIEF TO TANK)

NOTAS DO MICROCONTROLADOR (MICROPROCESSOR NOTES):

SENSORES DE PRESSÃO INDICAM (PRESSURE TRANSDUCERS INDICATE):

- PE-1 PRESSÃO DE ÓLEO (OIL PRESSURE MANIFOLD) 0-500 PSIA
- PE-2 PRESSÃO DE ÓLEO ANTES DO FILTRO (OIL PRESSURE BEFORE FILTER) 0-500 PSIA
- PE-3 PRESSÃO DE DESCARGA (DISCHARGE PRESSURE) 0-500 PSIA
- PE-4 PRESSÃO DE SUÇÃO (SUCTION PRESSURE) 0-200 PSIA

SENSORES DE TEMPERATURA INDICAM (TEMPERATURE PROBES INDICATE):

- TE-1 TEMPERATURA DE SUÇÃO (SUCTION GAS TEMPERATURE)
- TE-2 TEMPERATURA DE DESCARGA (DISCHARGE GAS TEMPERATURE)
- TE-3 TEMPERATURA DE ÓLEO (LUBE OIL TEMPERATURE)
- TE-4 TEMPERATURA SEPARADOR DE ÓLEO (SEPARATOR OIL TEMPERATURE)

DADOS DA UNIDADE COMPRESSORA PARAFUSO (SCREW COMPRESSOR PACKAGE DATA):

MODELO (MODEL): RWF1 399

BLOCO COMPRESSOR (COMPRESSOR BLOCK): SGC 2817

REFRIGERANTE (REFRIGERANT): R717

CONDIÇÃO DE OPERAÇÃO (WORKING CONDITION): T.E.: -46.0°C / T.C.: -10.0°C

VELOCIDADE (SPEED): 3550 RPM

CAPACIDADE (CAPACITY): 580.3KW

POTÊNCIA CONSUMIDA (SHAFT POWER): 181.6KW

DADOS MOTOR M1 (M1 MOTOR DATA): 220kW (300HP), FS(SF) 1.15, 3550RPM, 380V, 60HZ, IP-23, 280S/M, IE-3

TENSÃO DE COMANDO (CONTROL VOLTAGE): 220V, BOBINAS (COILS) 24VCC

CONTROLADOR (CONTROLLER): QUANTUM HD + PHD 4P

VOLUME DE ÓLEO (OIL VOLUME): 492L

NOTAS (PT):

- DESENHO DE SIMBOLOGIA DE REFERÊNCIA P & I (5419C020).
- A UNIDADE DEVE SER TESTADA A PRESSÃO DE TRABALHO DO LADO DE ALTA (21BAR).
- FORNECER FOLGA SUFICIENTE PARA REMOÇÃO E MANUTENÇÃO DO SLIDE VALVE.
- DESENHO DE ARRANJO GERAL: 4847CF399-032

Quadrante	Rev.	ECN/NAE	Descrição da revisão	Des.	Data des.	Ver.	Data ver.	AA	Data aprov.
-	0	-	EMISSÃO INICIAL	LRM	05/08/2021	FAR	05/08/2021	AA	05/08/2021

Cliente: MARRIG BATAGUASSU
 Título: UNIDADE COMPRESSORA (COMPRESSOR UNIT) RWF1 399
 Nº Pedido: 32107D.026
 Projeto:
 Formato: A1
 Substitui Desenho:
 Acabamento e tolerância conforme: 17-00.213-BE-BR
 Des. Nº.: 5415CF399-032
 Rev.: 0
 Folha nº.: 1/1

CLIENTE É RESPONSÁVEL POR PROVIDENCIAR E INSTALAR VÁLVULAS DE SEGURANÇA CASO O RESFRIADOR SEJA INSTALADO ENTRE VÁLVULAS DE BLOQUEIO. (CUSTOMER IS RESPONSIBLE FOR PROVIDING AND INSTALLING RELIEF PROTECTION IF COOLER IS ISOLATED)

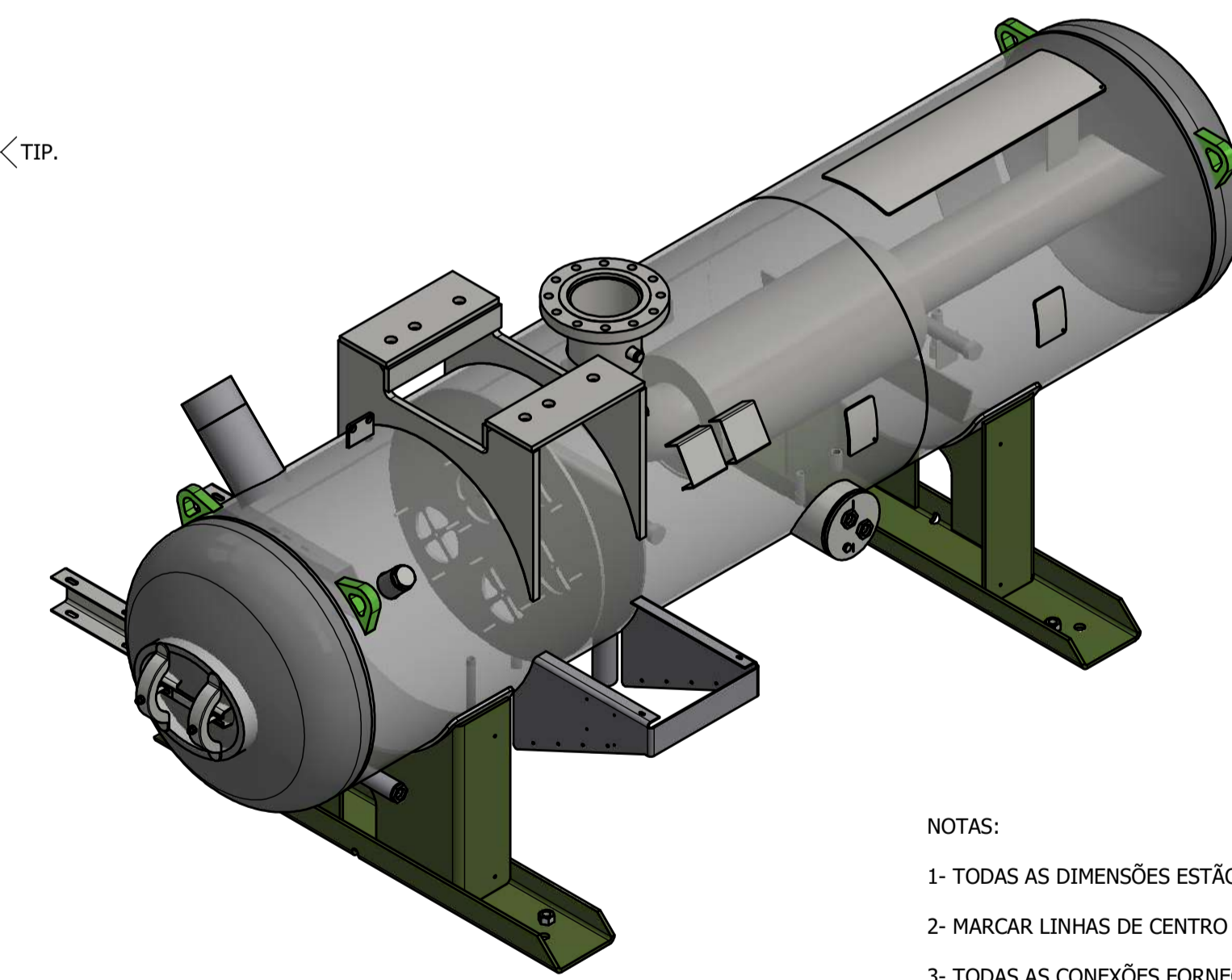
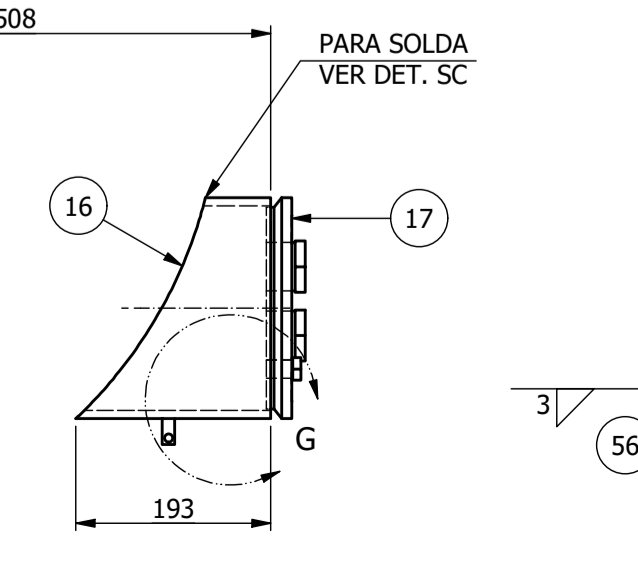
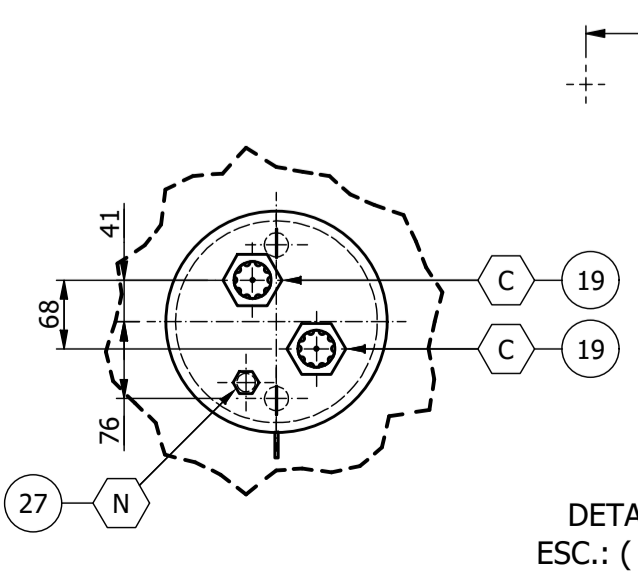
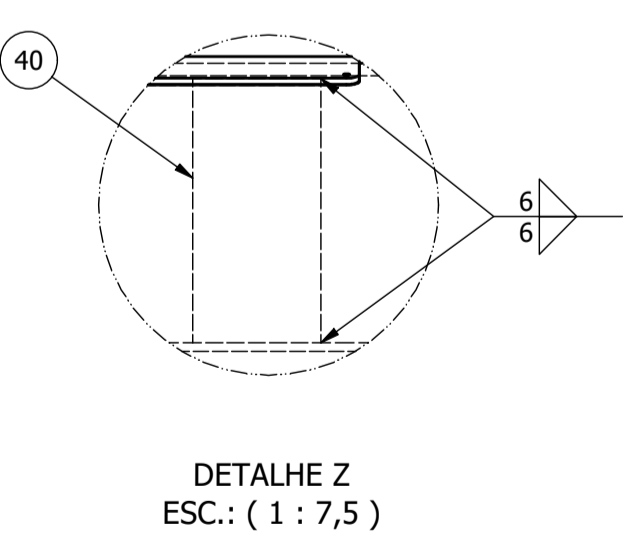
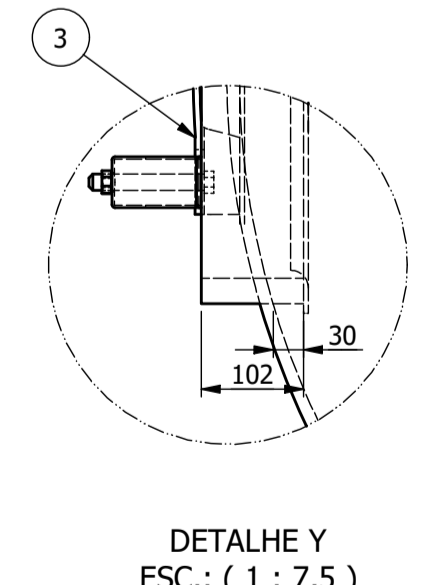
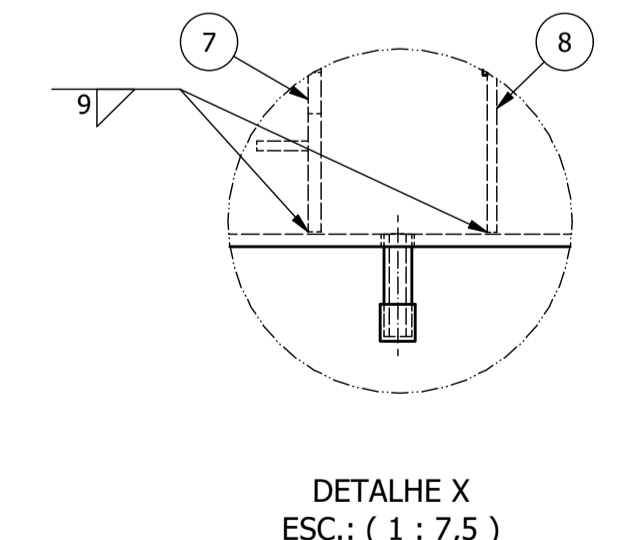
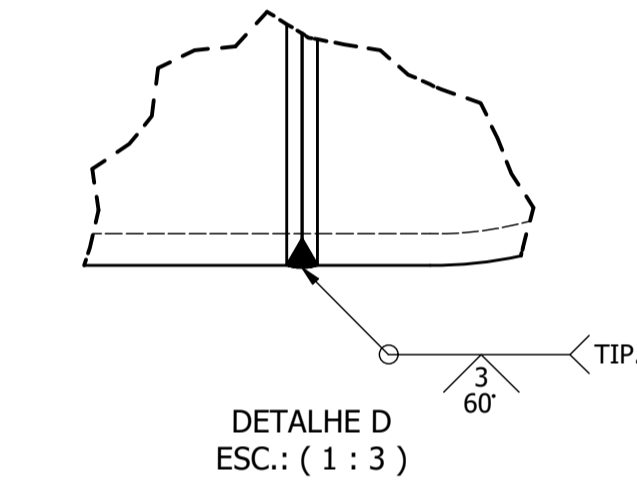
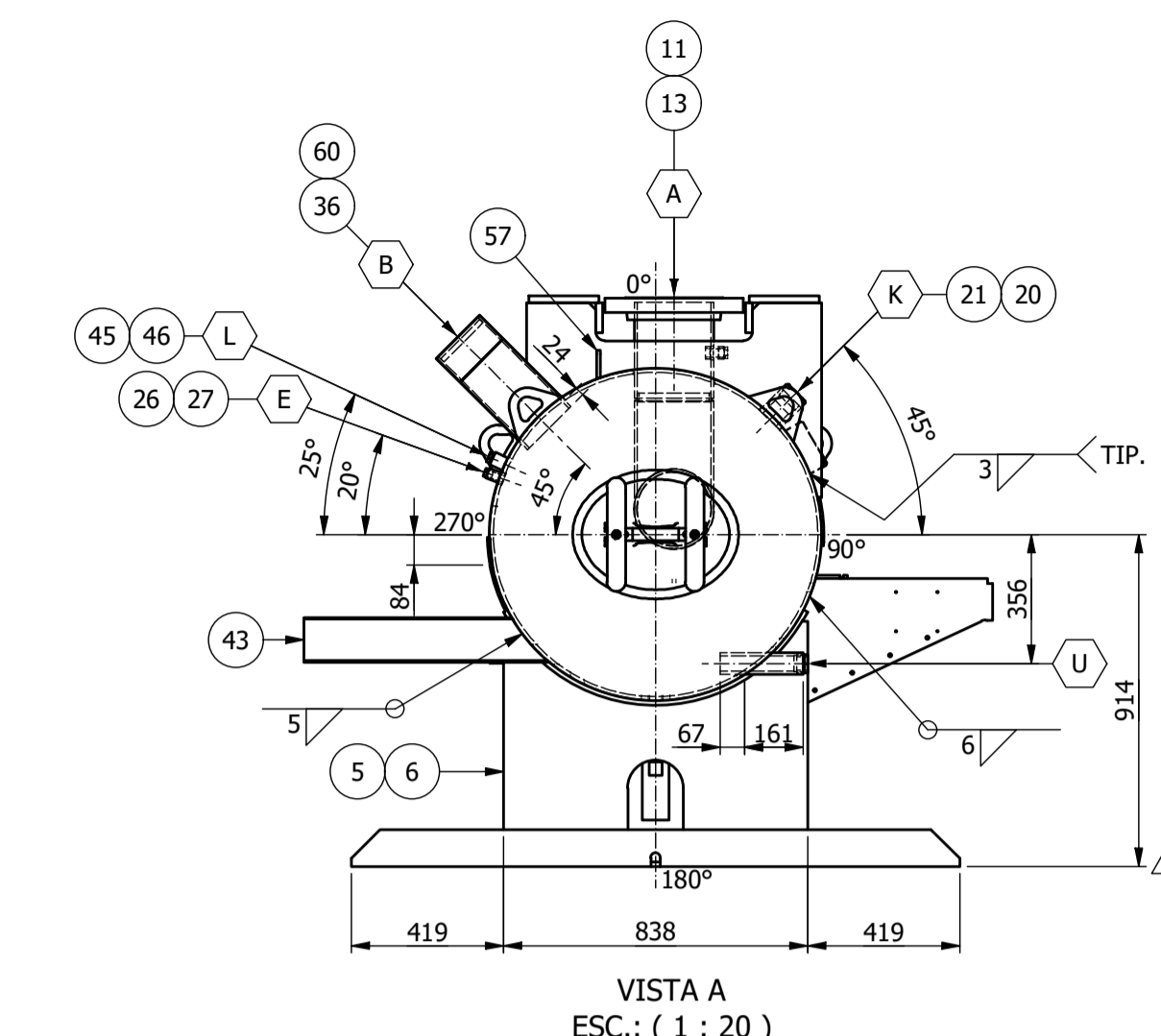
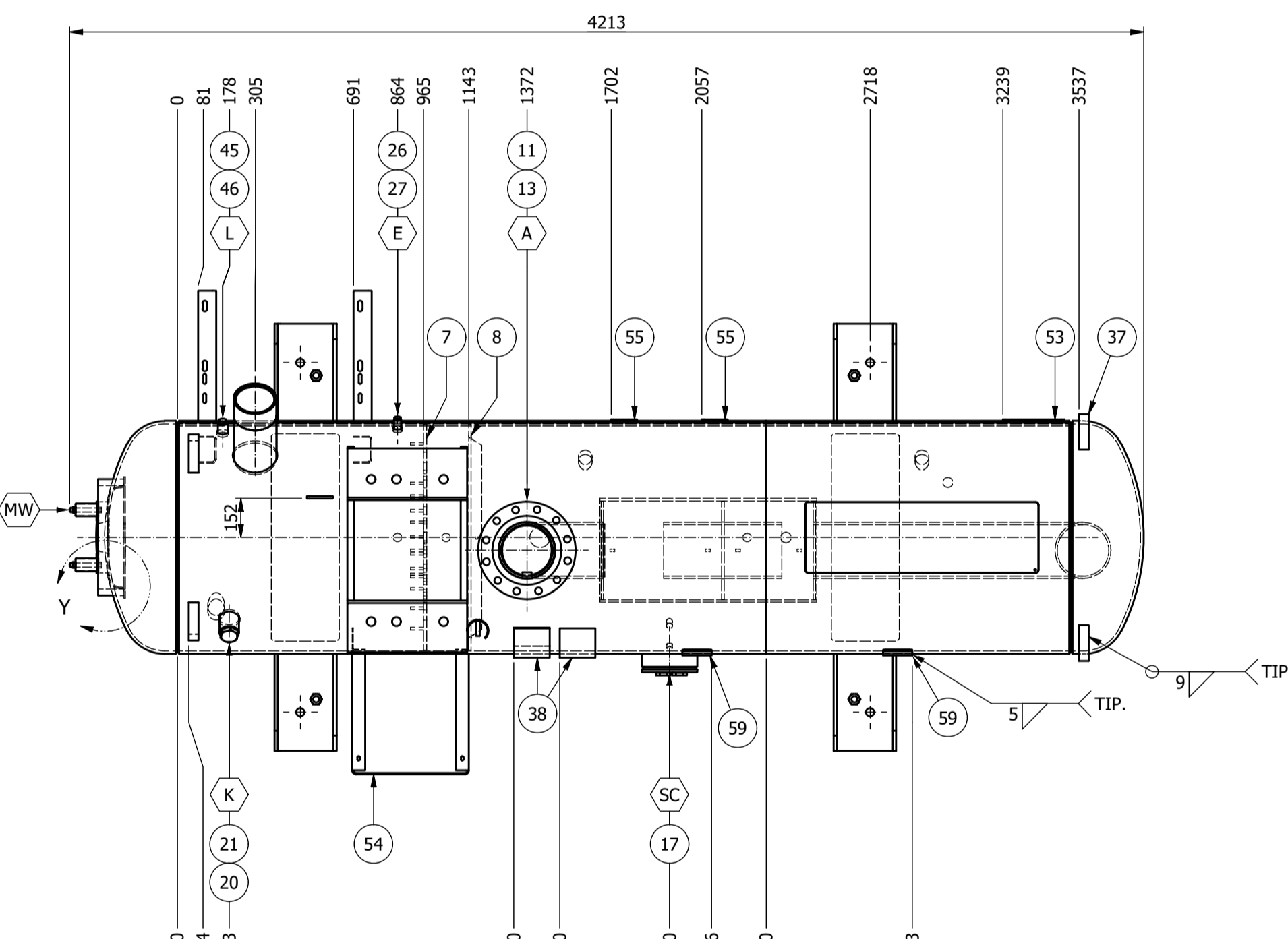
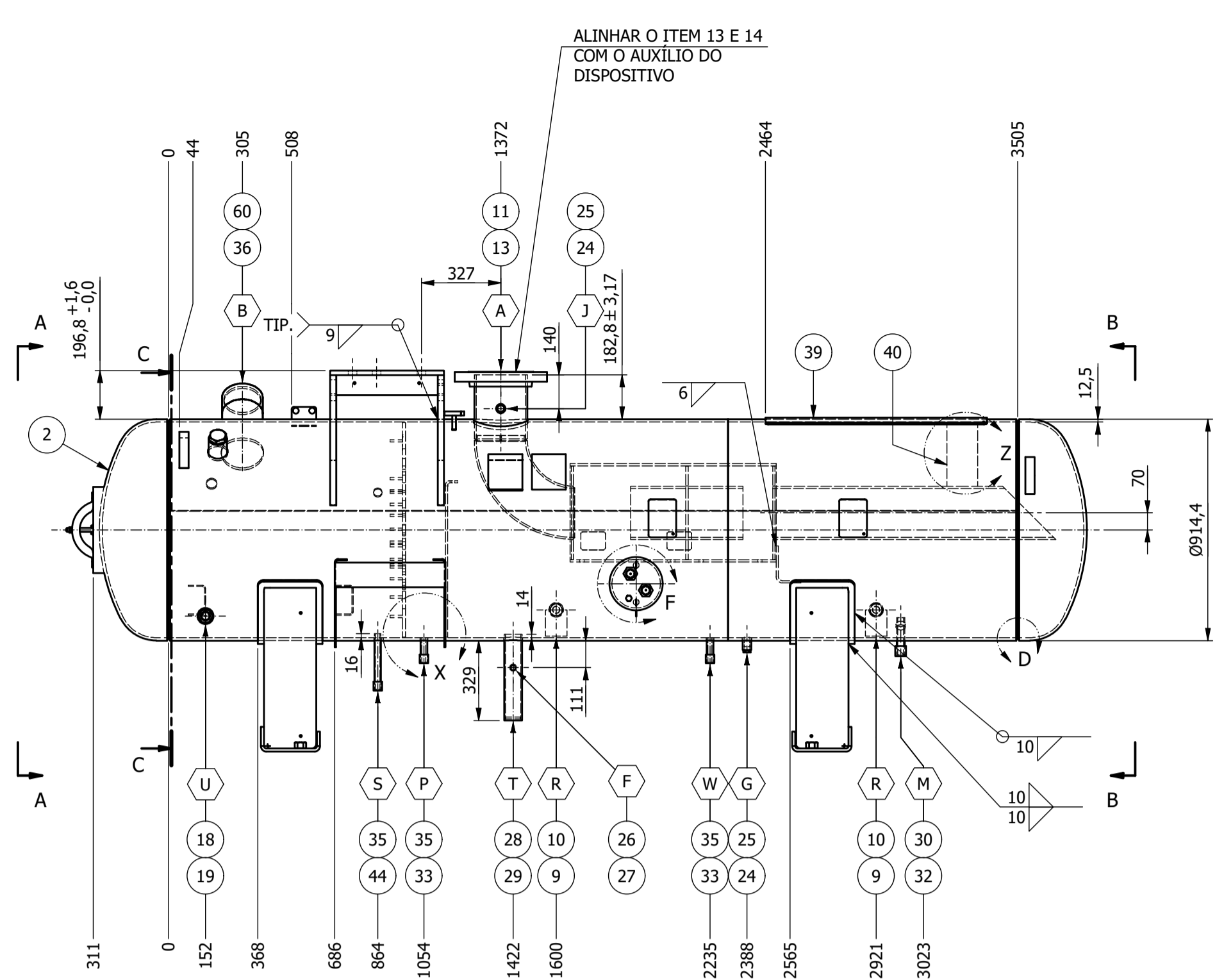
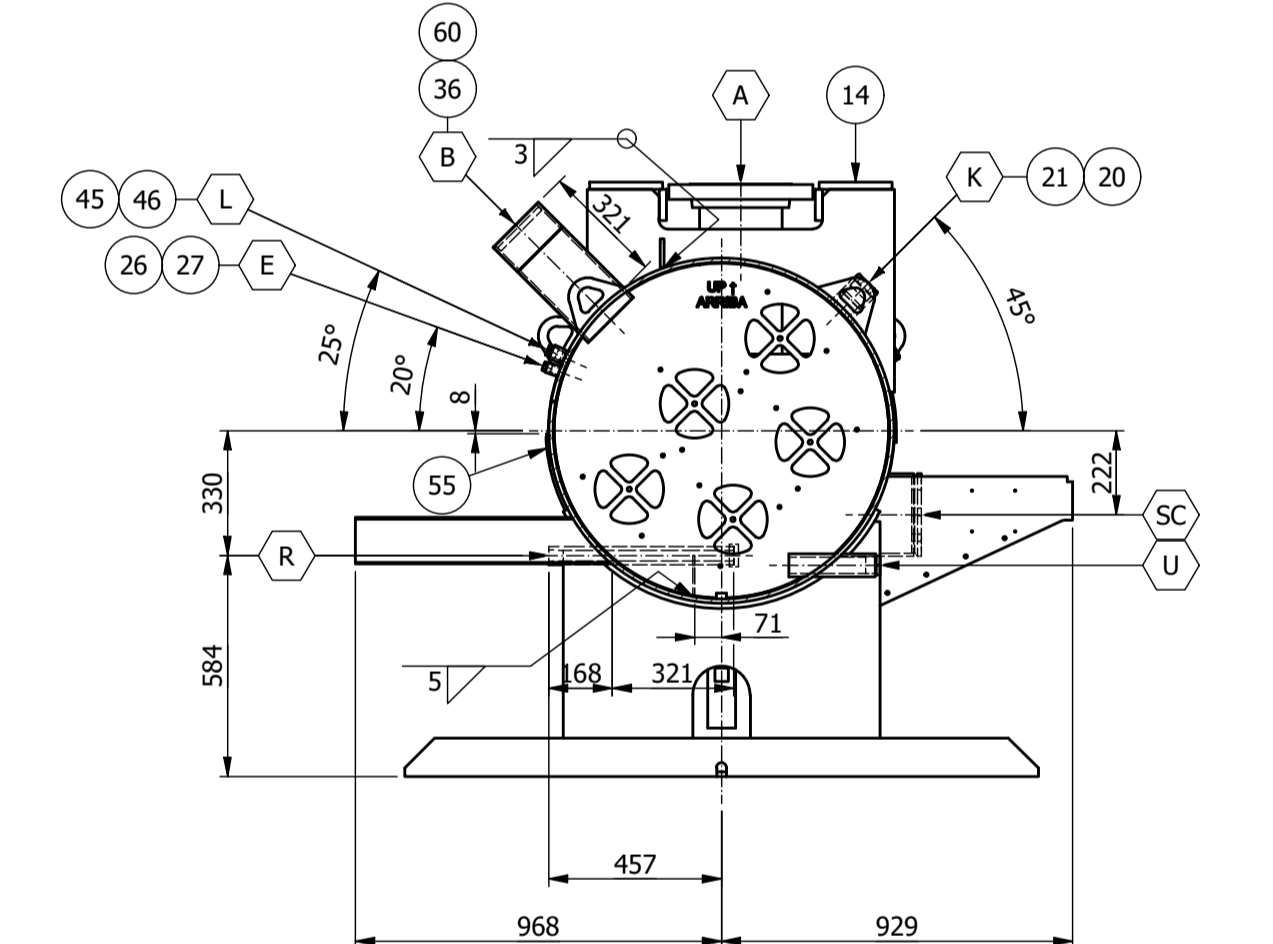
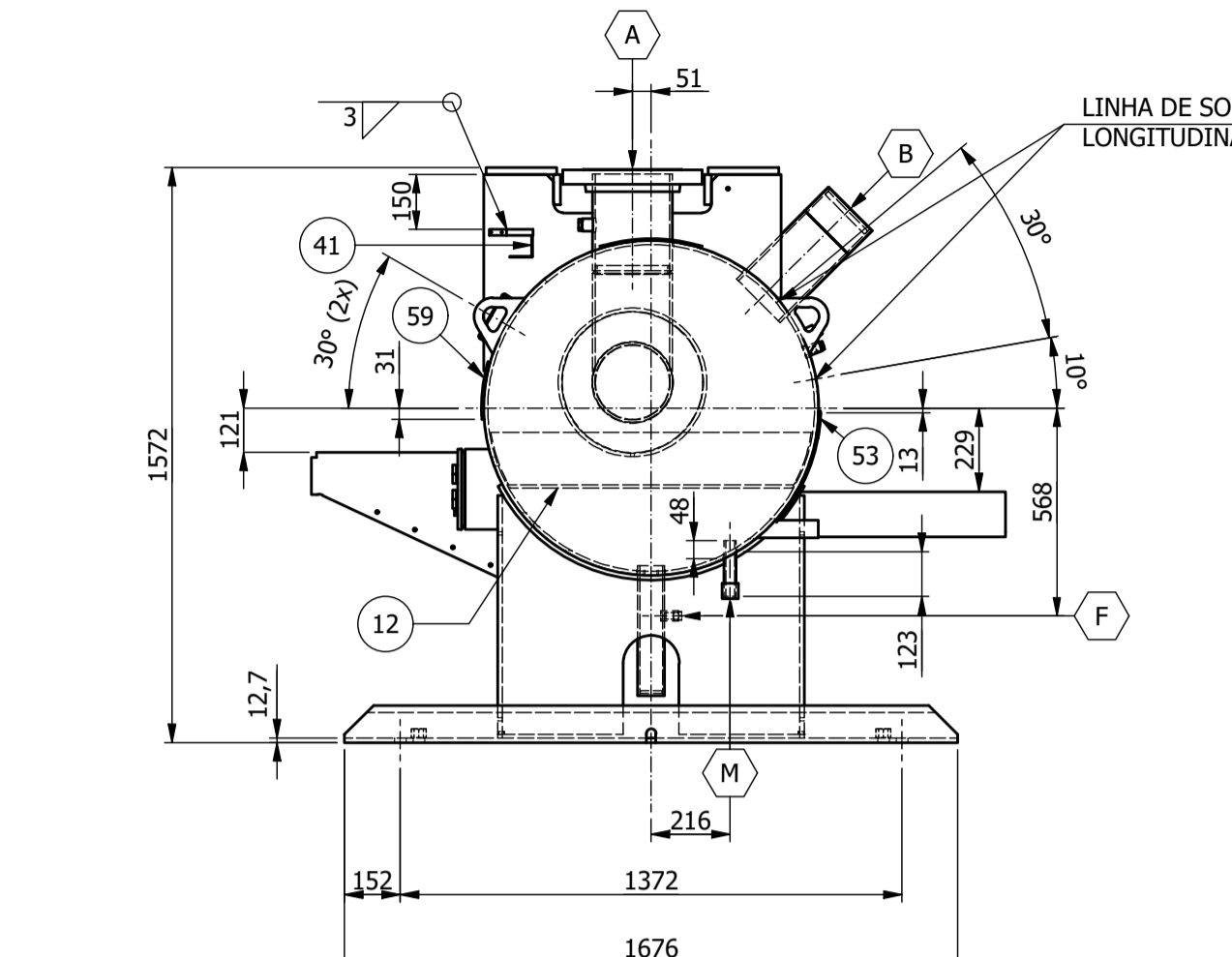
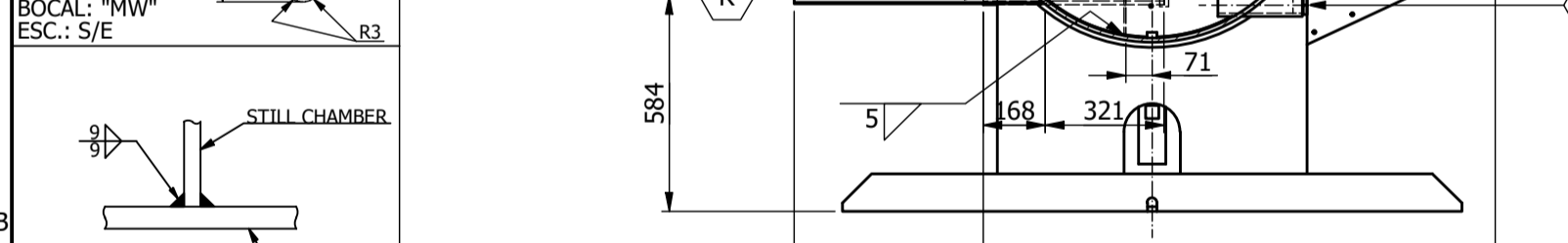
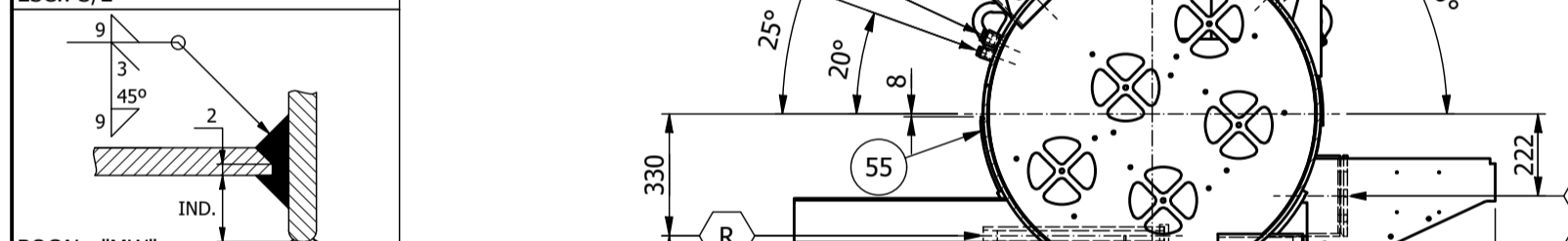
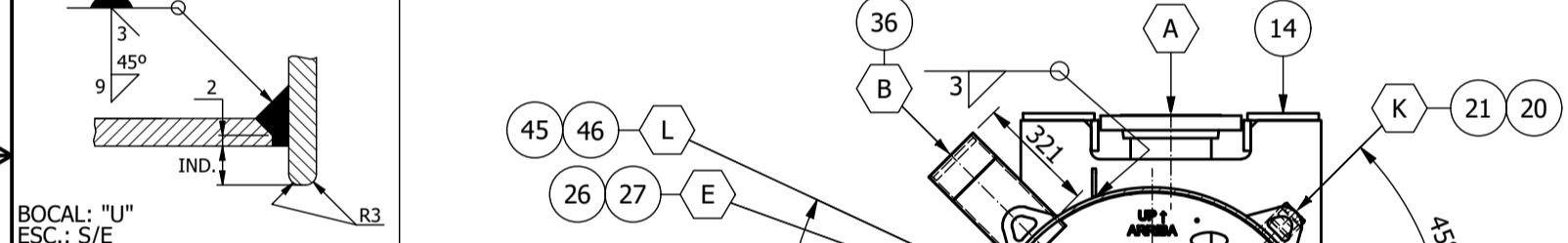
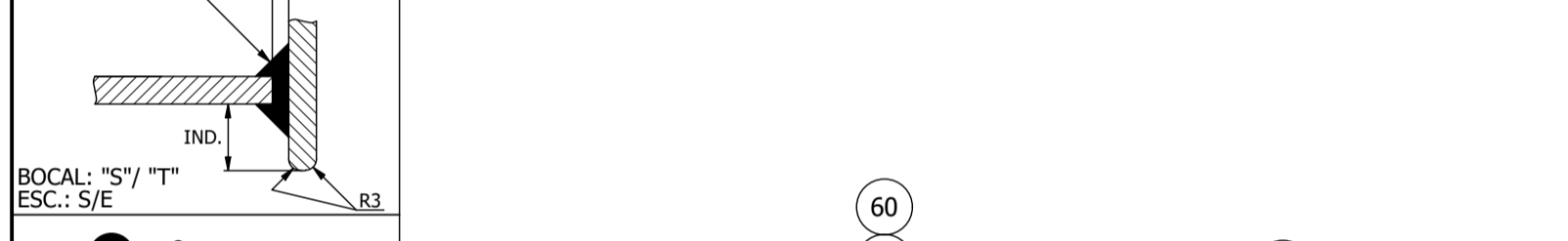
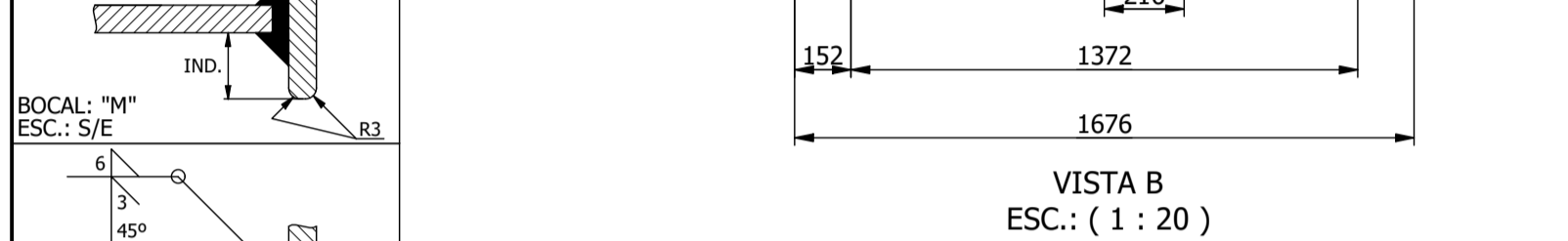
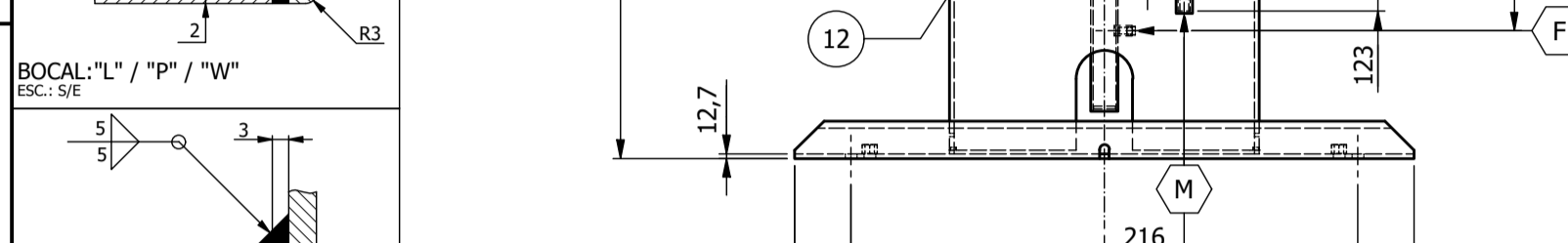
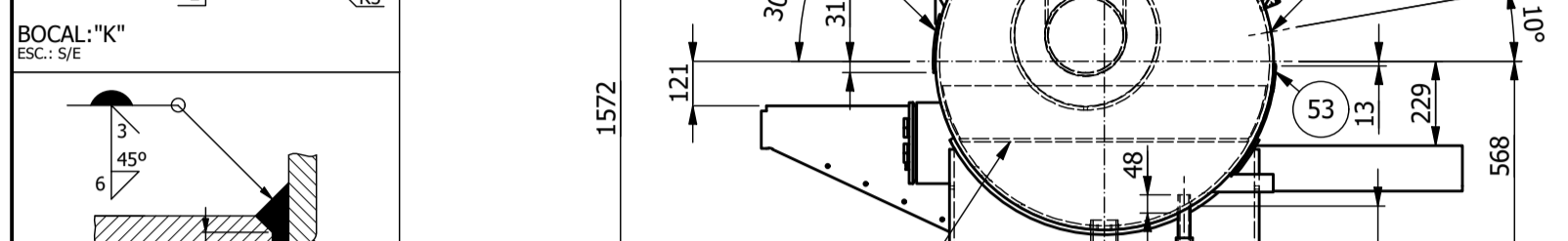
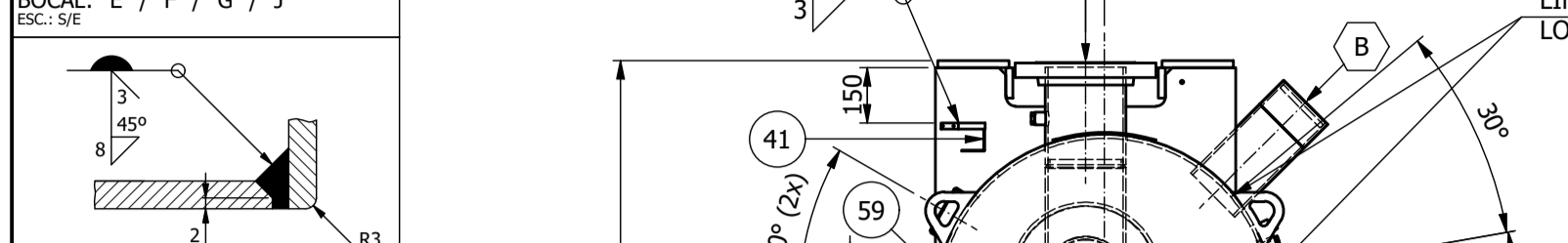
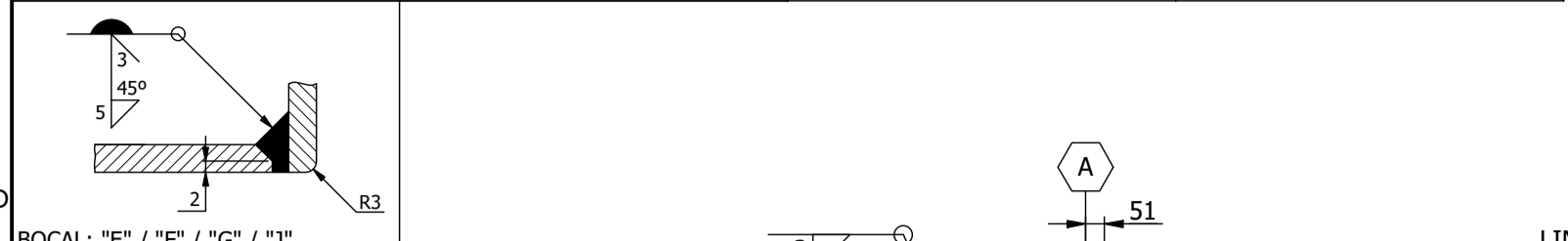
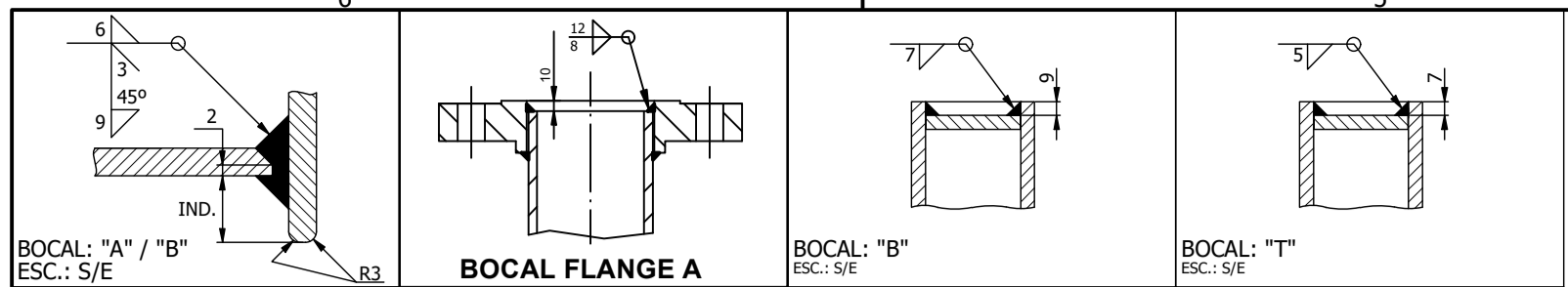

- NOTAS:
- TODAS AS DIMENSÕES ESTÃO EM MILÍMETROS, EXCETO ONDE INDICADO.
 - MARCAR LINHAS DE CENTRO HORIZONTAIS E VERTICAIS NO VASO PARA REFERÊNCIA NA MONTAGEM.
 - TODAS AS CONEXÕES FORNECIDAS COM TAMPAS TEMPORÁRIAS. AS TAMPAS TEMPORÁRIAS DEVEM SER REMOVIDAS ANTES DA OPERAÇÃO.
 - A MONTAGEM DEVE ESTAR LIMP, LIVRE DE REBARBAS, CAREPAS E RESPINGOS DE SOLDAS.
 - QUEBRAR TODOS OS CANTOS E ARESTAS.
 - ENSAYO DE LÍQUIDO PENETRANTE NO CHANFRO DA TAMPA DO STILL CHAMBER ANTES DE SOLDAR E NA BORDA APÓS SOLDAGEM.

CON	Qtd	ØN.	Sch.	Classe	Material	Descrição	ØFuro
A	1	8	40	300-SO-RF	SA-105/SA-106-B	ENTRADA DE VAPOR	225
B	1	6	40		SA-106-B	SAÍDA DE VAPOR	174
C	2	1.1/2	-		-	VISOR DE NÍVEL	-
E	1	1/2		3000 - LUVA - NPT	SA-105	INJEÇÃO DE LÍQUIDO	35
F	1	1/2		3000 - LUVA - NPT	SA-105	DRENO DE ÓLEO	35
G	1	3/4		3000 - LUVA - NPT	SA-105	SENSOR DE TEMPERATURA	41
J	1	3/4		3000 - LUVA - NPT	SA-105	SENSOR DE TEMPERATURA	41
K	1	2		3000 - SW/NPT	SA-105	VALVULA DE SEGURANÇA	82
L	1	3/4		3000 - SW/NPT	SA-105	PUMP OUT	44
M	1	1	80		SA-106-B	ALÍVIO DA BOMBA DE ÓLEO	39
N	1	1/2	-		SA-105	SENSOR DE NÍVEL DE ÓLEO	-
P	1	3/4	160		SA-106-B	DRENO DE ÓLEO	33
R	2	1.1/2	XXS		SA-106-B	RESISTÊNCIA DE AQUECIMENTO	54
S	1	3/4	160		SA-106-B	DRENO DO COALESCECER	33
T	1	2. 1/2	40		SA-106-B	SAÍDA DE ÓLEO	79
U	1	2	160		SA-106-B	VISOR DE NÍVEL	66
W	1	3/4	160		SA-106-B	DRENO DE ÓLEO	33
SC	1	8	40		SA-106-B	CÂMARA DE NÍVEL	-
MW	1	12x16	100		SA-106-B	BOCA DE VISITA	-

POS.	QTD.	CÓDIGO	DESCRIÇÃO	MATERIAL
1	1	548E0406H31BR	CASCO, ØE 914,4 x 3505 x 12,5MM	SA-516-70
2	2	2325C3003-1	TAMPO ELIP ASME 2-1, ØE 914,4 x 12,5 NOM. (10 MIN)	SA-516-70
3	1	535A0115H01	BOCA DE VISITA 12" x 16"	SA-106-B
5	2	535A0137H05BR	SELA PARA VASO HORIZONTAL, CH. 12,7 x 266,7 x 1019,2	SA-516-70
6	2	548C0683G01BR	SUPORTE DO SEPARADOR DE ÓLEO HOS-36	SA-516-70
7	1	548C0528G01	DIVISORIA PARA SEPARADOR, HOS-36 RWF 270	SA-516-70
8	1	548A0341H01BR	CHAPA DEFLETORA SEP OL DN 36"	SA-516-70
9	2	2529C001-003	POÇO P/ RESISTENCIA DE AQUECIMENTO, DN 1.1/2 SCH XXS x 508MM	SA-106-B
10	2	535A0211H09BR	SUPORTE P/ POÇO DA RESISTENCIA DE AQUECIMENTO, DN-36"	SA-516-70
11	1	548C0627G01BR	SILENCIADOR DN. 8" PARA SEPARADOR DE ÓLEO HOS-36	SA-106-B
12	1	548C0637H01BR	SUPORTE DO SILENCIADOR 8", VASO DN 914,4	SA-516-70
13	1	1344I2172S	FLANGE SO RF, DN.8" - 300#	SA-105
14	1	548C0535G01BR	BASE COMPRESSORA P/ SEP. ÓLEO HOS-36	SA-516-70
16	1	548B0264H01BR	TUBO P/ STILL CHAMBER, DN 8" SCH 40 VASO DN 914,4	SA-106-B
17	1	548B0291H01BRF	TAMPA FRONTAL P/ VISOR DE NÍVEL, DN 1 1/2" CH. 25,4 x ØE 219	SA-516-70
18	1	548A0258H12S	LUVA LONGA, 2 SCH 160 x 9"	SA-106-B
19	3	947A0003H07S	VISOR DE NÍVEL TIPO BUJÃO, 1 1/2" NPT	SA-105
20	1	944A0130H09S	LUVA TIPO COUPOLET, DN. 2" SW - 3000#	SA-105
21	1	944A0129H09S	BUJÃO SEXTAVADO LONGO, DN. 2 POL. 6000#	SA-105
24	2	1342+945S	LUVA, DN.3/4" NPT - 3000#	SA-105
25	2	1343+174S	BUJÃO SEXTAVADO, DN.3/4 NPT - 6000#	SA-105
26	2	1342+998S	LUVA, DN.1/2" NPT - 3000#	SA-105
27	3	1343+173S	BUJÃO SEXTAVADO, DN.1/2 NPT - 6000#	SA-105
28	1	2163C249-28	TUBO, DN.3/4", SCH 160 x 102 C/ ROSCA NPT	SA-106-B
29	1	2325+913F	TAMPA PLANA, ØE60 x 8,0	SA-516-70
30	1	1346I904S	CAP. DN. 1, CL3000	SA-105
32	1	944A0087H23	TUBO, DN.1", SCH 80 x 152 C/ ROSCA NPT	SA-106-B
33	2	944A0086H22	TUBO, DN.3/4", SCH 160 x 102 C/ ROSCA NPT	SA-106-B
35	3	1346I625S	CAP. DN. 3/4, CL3000	SA-105
36	1	2163C268	TUBO, DN.6" SCH 40	SA-106-B

POS.	QTD.	CÓDIGO	DESCRIÇÃO	MATERIAL
37	4	945B0001H02BR	OLHAL DE ICAMENTO P/ VASO HORIZONTAL	SA-516-70
38	2	540A0160H01	SUP. PLAQUETA 140 x 140 x 52	SA-516-70
39	1	548A0324H01BR	SELA P/ MONTAGEM DO MOTOR, CH. 6,3 x 914,4 x 210	SA-516-70
40	1	548A0368H01BR	CHAPA DE APOIO DO SILENCIADOR, CH. 9,5 x 317,5 x 127	SA-516-70
41	1	2214C207S	SUPORTE PARA GARRAFA PLÁSTICA	SA-516-70
43	2	548B0240H01BR	SUPORTE PARA FILTRO DE ÓLEO, VASO DN 914,4	SA-516-70
44	1	944A0451J3BR	TUBO, DN 3/4" SCH 160, 230MM	SA-106-B
45	1	944A0130H05S	LUVA TIPO COUPOLET, DN. 3/4" SW - 3000#	SA-105
46	1	944A0129H05S	BUJÃO SEXTAVADO LONGO, DN. 3/4 POL. 6000 LBS	SA-105
53	1	548A0418H01BR	SELA PARA MONTAGEM DA BOMBA, VASO DN 914,4	SA-516-70
54	1	548D1713H01BR	SUPORTE P/ MONTAGEM DO CONTRALDOR, DN 914,4	SA-516-70
55	2	535A0301H01	SELA PARA VASO DN 762	SA-516-70
56	1	720A0035H03BR	SUPORTE PARA CABEAMENTO, CH 3 x 25 x 13	SA-516-70
57	1	548A0384H01BR	SUPORTE DO SENSOR DE PRESSÃO, CH. 9,5 x 102 x 76	SA-516-70
59	2	548A0362H01BR	SELA PARA VASO DN 914,4	SA-516-70
60	1	2325+909F	TAMPA PLANA, ØE152 x 12,5	SA-516-70

CODIGO E NORMAS	
CODIGO DO PROJETO:	ASME SEÇÃO VIII DIV. 1, EDIÇÃO 2019
NORMAS APLICÁVEIS:	
DADOS DE PROJETO	
PRESSÃO DE PROJETO:	21 bar(G)
PRESSÃO MAX. DE TRABALHO ADMISSÍVEL:	21 bar(G)
PRESSÃO DE TESTE PNEUMÁTICO:	23,5 bar(G)
TEMPERATURA DE PROJETO:	120 °C
TEMPERATURA DE OPERAÇÃO:	- °C
MDMT:	-29 °C
CORROSÃO ADMISSÍVEL:	0 mm
RADIOGRAFIA:	NÃO
LÍQUIDO PENETRANTE:	100% DAS SOLDAS
TESTE DE IMPACTO:	NÃO POR UCS-66
TRATAMENTO TÉRMICO (PWHT):	NÃO
PESO DO EQUIPAMENTO	
PESO VAZIO:	2050 kg
PESO EM OPERAÇÃO:	- kg
PESO CHEIO D'ÁGUA:	4450 kg
DADOS GERAIS	
NUMERO DE SÉRIE:	CONFORME PI (VER PLAQUETA)
VOLUME:	2,409 m³
ISOLAMENTO:	-
PINTURA:	STANDARD
TOLERÂNCIAS DIMENSIONAIS:	17.00.213-BE-BR-REV.5
INSPEÇÃO:	JCI / ASME

TABELA DE CONEXÕES							
CON	Qtd	ØN.	Sch.	Classe	Material	Descrição	ØFuro
A	1	8	40	300-SO-RF	SA-105/SA-106-B	ENTRADA DE VAPOR	225
B	1	6	40		SA-106-B	SAÍDA DE VAPOR	174
C	2	1.1/2	-		-	VISOR DE NÍVEL	-
E	1	1/2		3000 - LUVA - NPT	SA-105	INJEÇÃO DE LÍQUIDO	35
F	1	1/2		3000 - LUVA - NPT	SA-105	DRENO DE ÓLEO	35
G	1	3/4		3000 - LUVA - NPT	SA-105	SENSOR DE TEMPERATURA	41
J	1	3/4		3000 - LUVA - NPT	SA-105	SENSOR DE TEMPERATURA	41
K	1	2		3000 - SW/NPT	SA-105	VALVULA DE SEGURANÇA	82
L	1	3/4		3000 - SW/NPT	SA-105	PUMP OUT	44
M	1	1	80		SA-106-B	ALÍVIO DA BOMBA DE ÓLEO	39
N	1	1/2	-		SA-105	SENSOR DE NÍVEL DE ÓLEO	-
P	1	3/4	160		SA-106-B	DRENO DE ÓLEO	33
R	2	1.1/2	XXS		SA-106-B	RESISTÊNCIA DE AQUECIMENTO	54
S	1	3/4	160		SA-106-B	DRENO DO COALESCECER	33
T	1	2. 1/2	40		SA-106-B	SAÍDA DE ÓLEO	79
U	1	2	160		SA-106-B	VISOR DE NÍVEL	66
W	1	3/4	160		SA-106-B	DRENO DE ÓLEO	33
SC	1	8	40		SA-106-B	CÂMARA DE NÍVEL	-
MW	1	12x16	100		SA-106-B	BOCA DE VISITA	-

HISTÓRICO DE REVISÕES			
REV.	ECV/NAE	DESCRIÇÃO DA REVISÃO	DES. DATA DES. VER. DATA VER. AFR. DATA AFR.
-	8	BR20-0156 ALTERADO REVISÃO DA TOLERÂNCIA	LFM 10/08/2020 LBM 10/08/2020 AA 10/08/2020
-	7	BR20-0143 ALT. TUBO BOCAL "B" COM DET. CORTE	LFM 03/08/2020 LBM 03/08/2020 AA 03/08/2020
-	6	BR20-0096 REVISÃO GERAL	LFM 14/04/2020 LBM 14/04/2020 AA 14/04/2020

CLIENTE:	TÍTULO: SEPARADOR DE ÓLEO HORIZONTAL		
Nº PEDIDO:	HOS-36		
PROJETO:	RWF II 316/399 (PADRÃO)		
FORMATO: A1	ESCALA: 1 : 20	DES. Nº.:	548E0406G31BR
SUBSTITUIÇÃO DESENHO:		REV.:	8
ACABAMENTO E TOLERÂNCIA CONF.: 17-00.213-BE-BR		FOLHA Nº.	1 / 1

CODIGO E NORMAS	
CODIGO DO PROJETO:	ASME SEÇÃO VIII DIV. 1, EDIÇÃO 2019
NORMAS APLICÁVEIS:	-
DADOS DE PROJETO	
PRESSÃO DE PROJETO:	28 bar(G)
PRESSÃO MAX. DE TRABALHO ADMISSÍVEL:	28 bar(G)
PRESSÃO DE TESTE (PNEUMÁTICO):	31 bar(G)
TEMPERATURA DE PROJETO:	120 °C
TEMPERATURA DE OPERAÇÃO:	- °C
MDMT:	-29 °C
CORROSÃO ADMISSÍVEL:	0 mm
RADIOGRAFIA:	NÃO
LIQUIDO PENETRANTE:	100% DAS SOLDAS
TESTE DE IMPACTO:	NÃO POR UCS-66
TRATAMENTO TÉRMICO (PWHT):	NÃO
PESO DO EQUIPAMENTO	
PESO VAZIO:	91 kg
PESO EM OPERAÇÃO:	- kg
PESO CHEIO D'ÁGUA:	136 kg
DADOS GERAIS	
NUMERO DE SÉRIE:	CONFORME PI (VER PLAQUETA)
VOLUME:	0,043 m³
ISOLAMENTO:	-
PINTURA:	STANDARD
TOLERÂNCIAS DIMENSIONAIS:	17.00.213-BE-BR-REV.5
INSPEÇÃO:	JCI / ASME
CLASSIFICAÇÃO NR-13	
CLASSE:	A
GRUPO:	5
CATEGORIA:	III

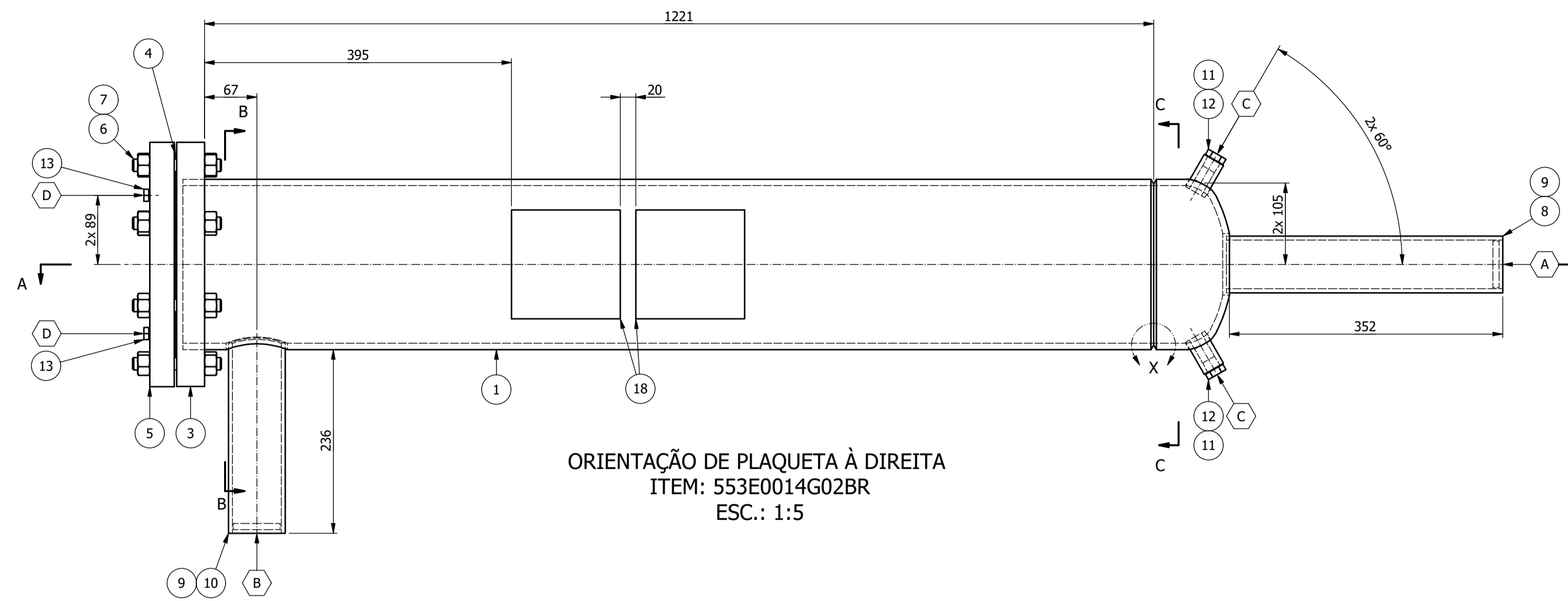
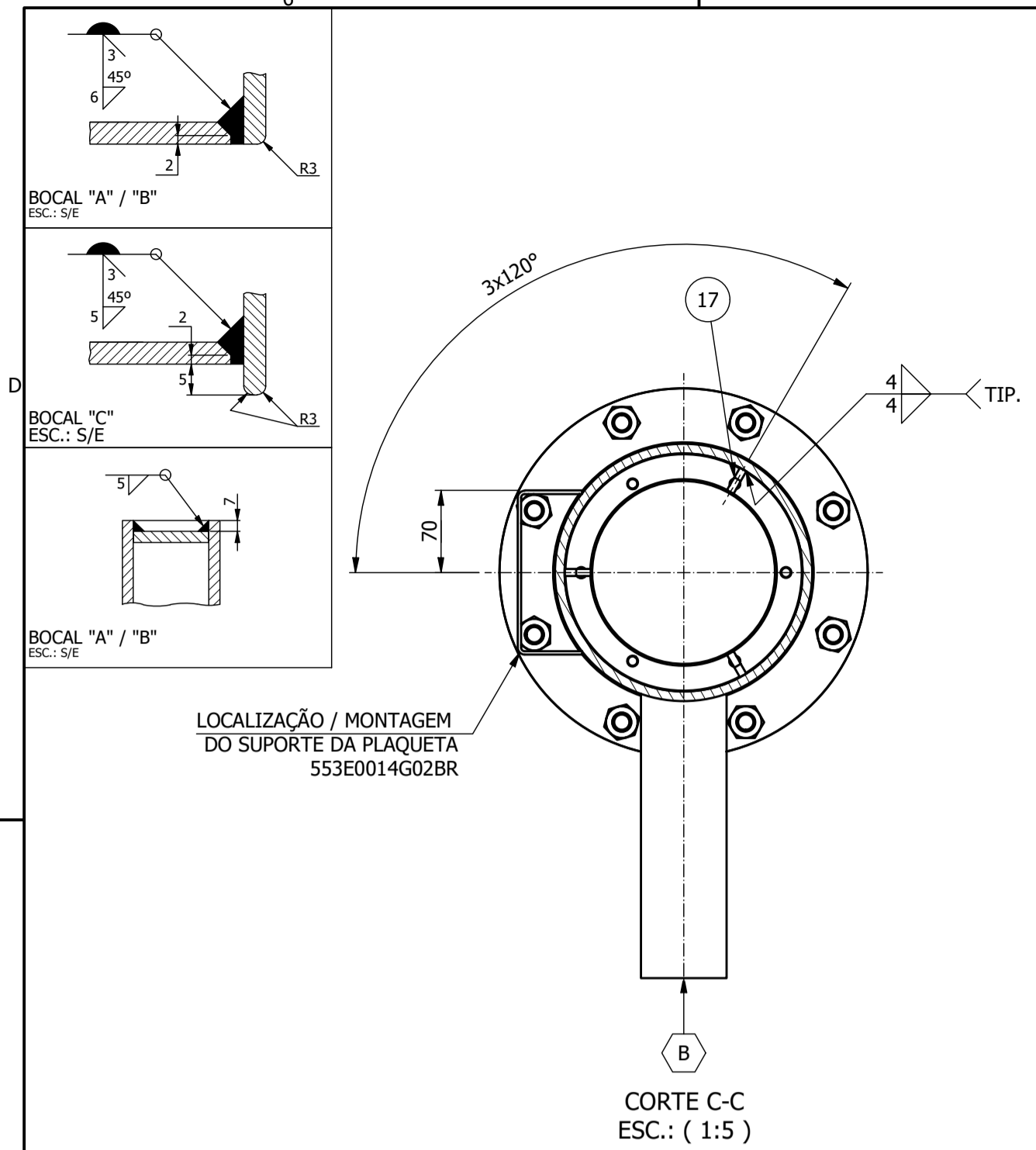

ORIENTAÇÃO DE PLAQUETA À DIREITA
ITEM: 553E0014G02BR
ESC.: 1:5

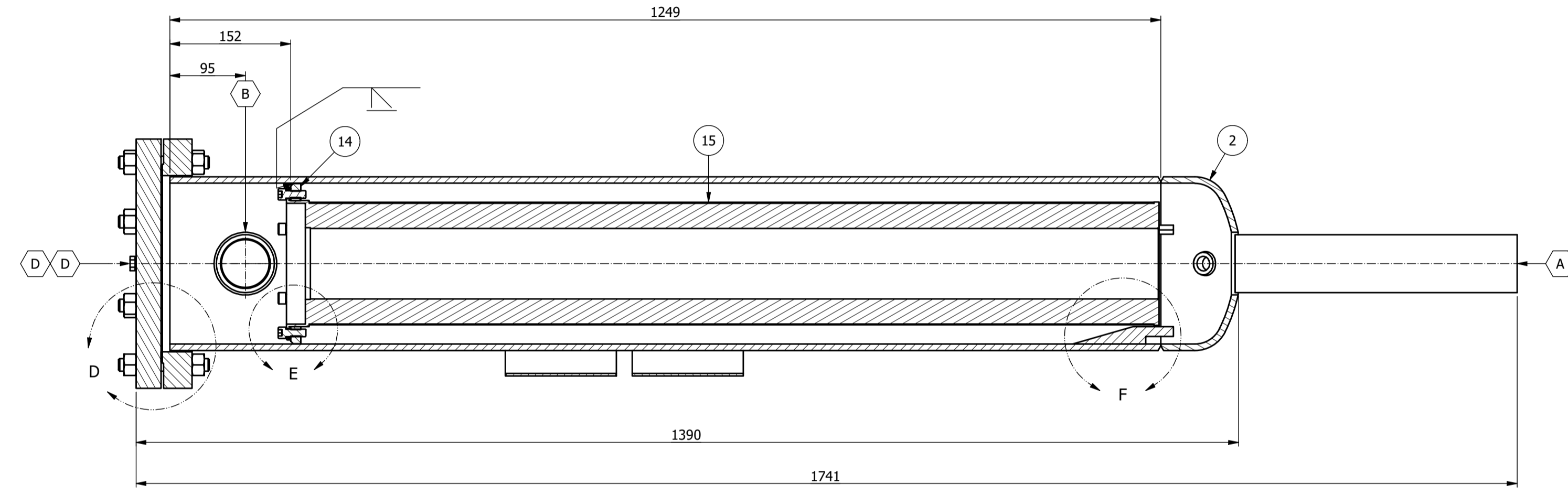
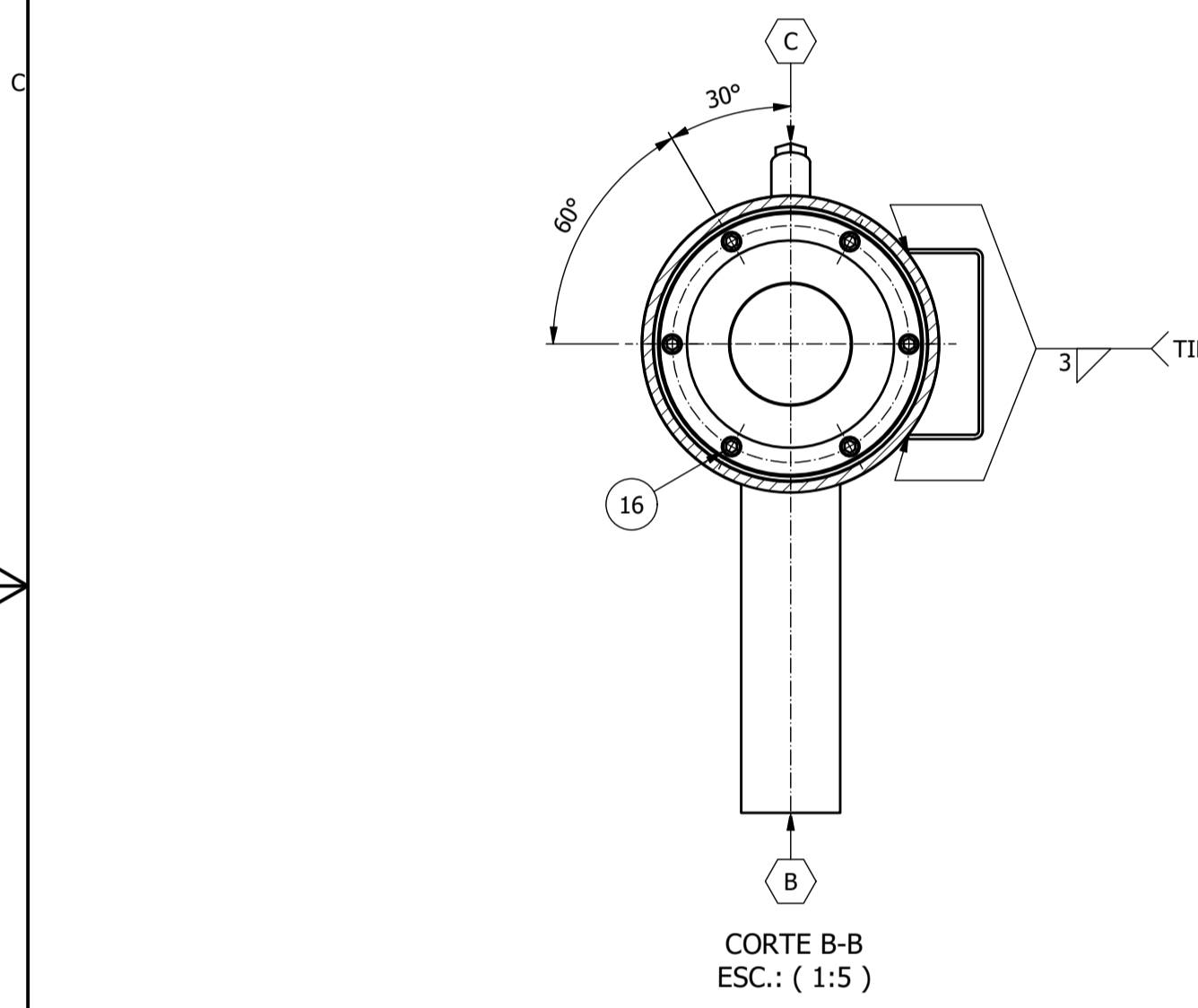

CORTE A-A
ESC.: (1:5)

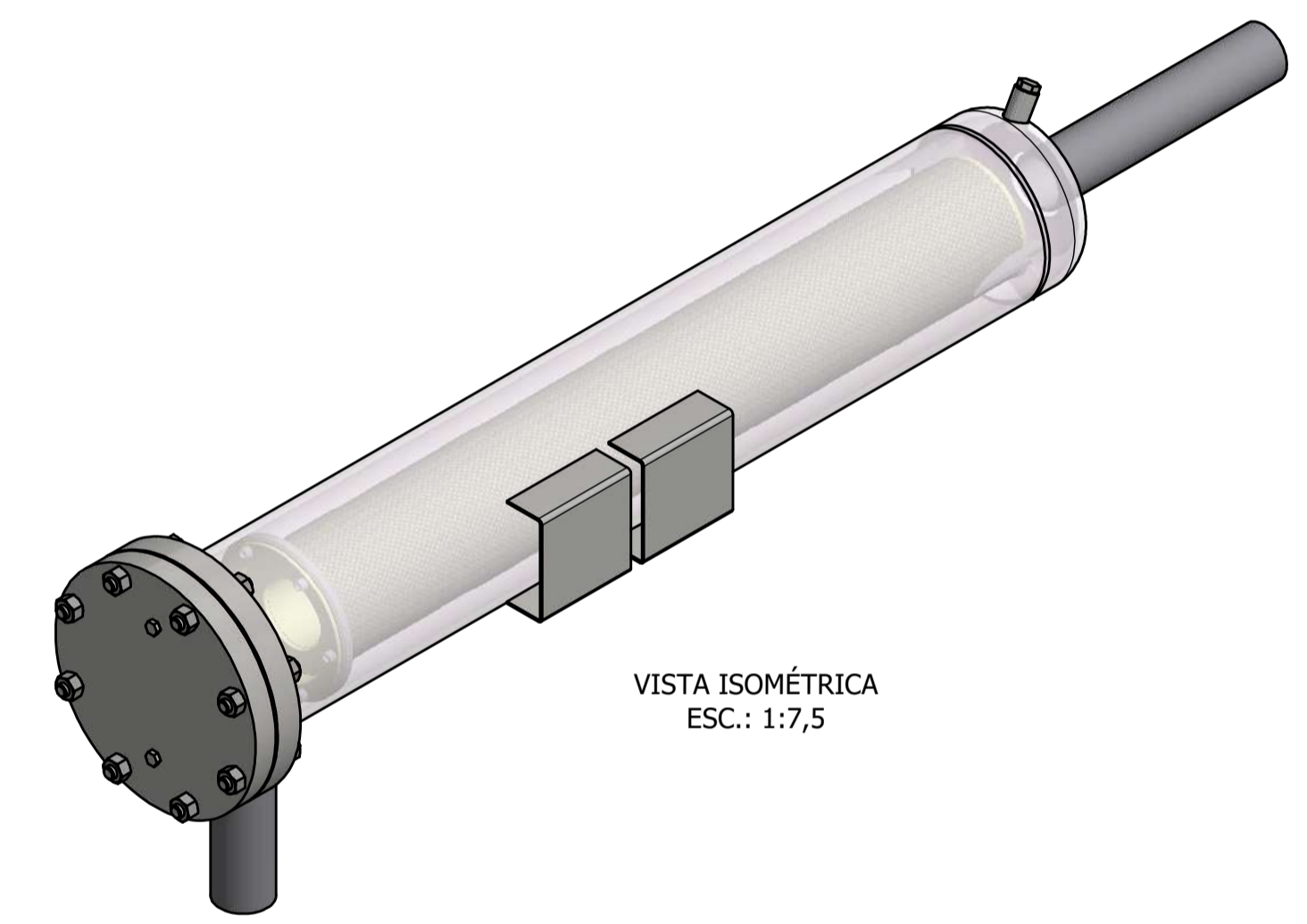

VISTA ISOMÉTRICA
ESC.: 1:7,5

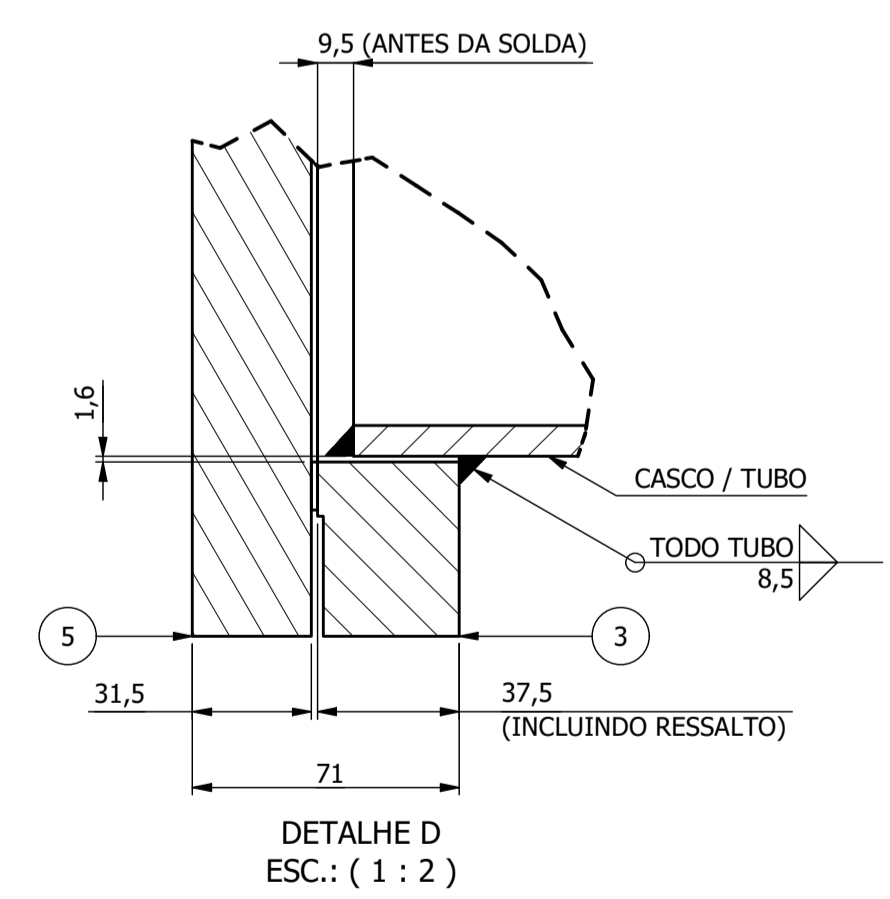

DETALHE D
ESC.: (1:2)

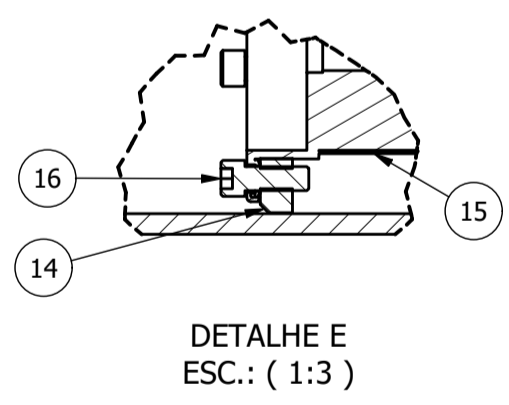

DETALHE E
ESC.: (1:3)

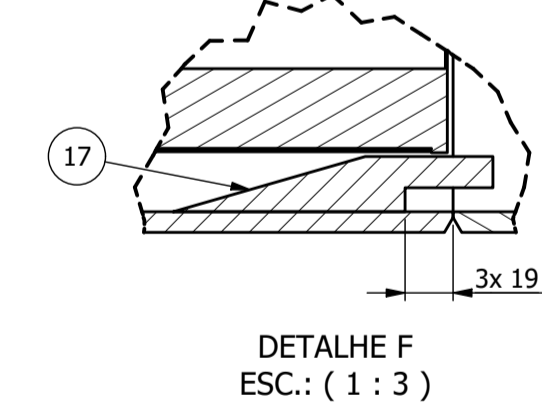

DETALHE F
ESC.: (1:3)

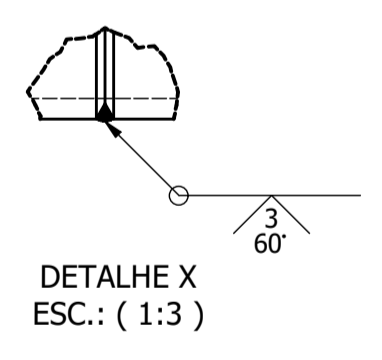

DETALHE X
ESC.: (1:3)

POS.	QTD.	CÓDIGO	DESCRIÇÃO	MATERIAL	553E0014G02/03BR (VER NOTA 7)	553E0014G99BR (VER NOTA 7)
0	1	553E0014G99BR	FILTRO DE ÓLEO SEM CONEXÃO E PLAQUETAS	-	X	
1	1	553E0014H01BR	CASCO, DN.8 POL SCH 40 - FO-CX2.1/2 POL.	SA-106-B		X
2	1	1346+806S	CAP, DN.8" SCH 40	SA-234-WPB		X
3	1	553A0011H01BR	FLANGE ANEL Ø314 x CH.37,5	SA-516-70		X
4	1	553B0011H01S	JUNTA DE VEDAÇÃO, ESP. 1,6 ØE 247,65 ØI 222,25	GARLOCK 3300	X	
5	1	553A0001H01BR	FLANGE CEGO Ø314 x CH.31,5	SA-516-70		X
6	8	1429+1010S	ESTOJO, Ø5/8" UNC x 4 1/2"	SA-193-B7	X	
7	16	1432+092S	PORCA SEXTAVADA Ø5/8" UNC - PESADA	SA-194-2H	X	
8	356 mm	1112+199S	TUBO DN.2 1/2" SCH 40	SA-106-B		X
9	2	2325+913F	TAMPA PLANA, Ø660 x 8,0	SA-516-70		X
10	254 mm	1112+199S	TUBO DN.2 1/2" SCH 40	SA-106-B		X
11	2	1342+998S	LUVA, DN.1/2" NPT - 3000#	SA-105		X
12	2	1343+173S	BUJÃO SEXTAVADO, DN.1/2 NPT - 6000#	SA-105		X
13	2	1343+172S	BUJÃO SEXTAVADO, DN.1/4 NPT - 6000#	SA-105		X
14	1	553A0018H01BR	ANEL DE FIXAÇÃO DO ELEMENTO DO FILTRO DE ÓLEO DN.8" x ESP.12,5	SA-516-70		X
15	1	531B010H03S	ELEMENTO DO FILTRO DE ÓLEO - SUPER FILTER II, 6" OD X 43 5/16" LG	-	X	
16	6	1422+951S	PARAFUSO, CABEÇA ALLEN Ø3/8" x 1"	SA-307-A	X	
17	3	553A0002H02BR	GUIA DO FILTRO, ESP.6,35	SA-516-70		X
18	2	540A016H01	SUP PLAQUETA 140 x 140 x 52	SA-516-70	X	

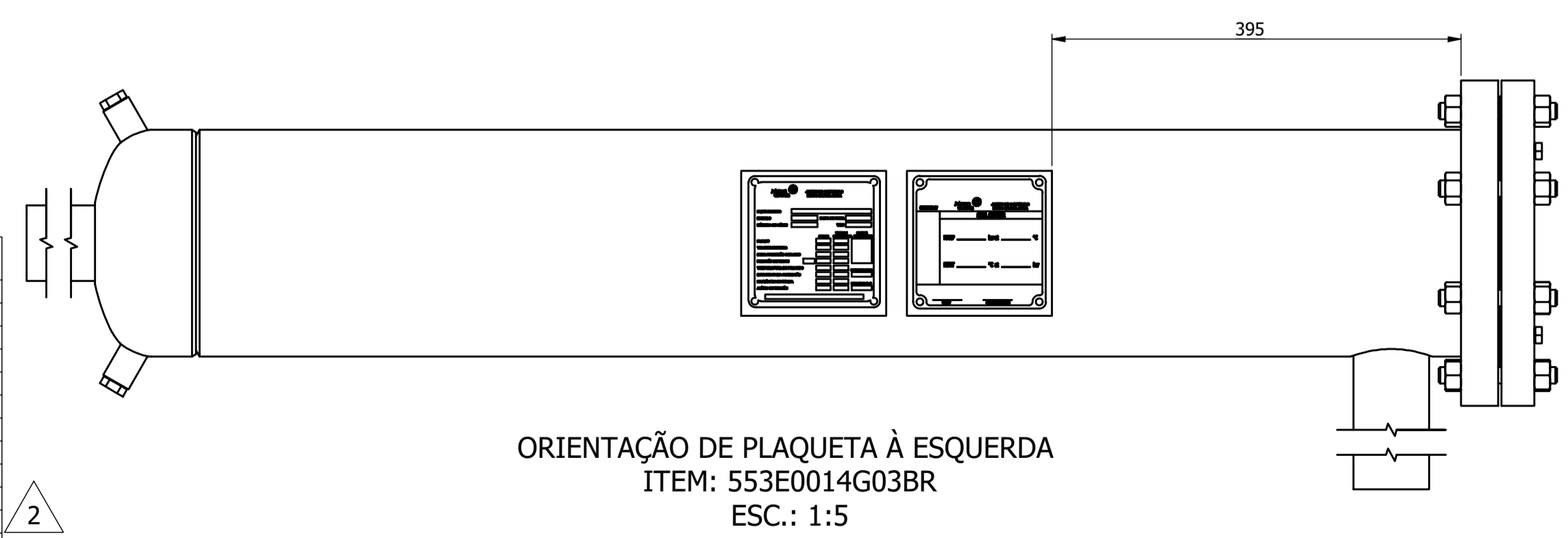

ORIENTAÇÃO DE PLAQUETA À ESQUERDA
ITEM: 553E0014G03BR
ESC.: 1:5

TABELA DE CONEXÕES						
CON	Qtd	ØN.	Sch.	Classe	Descrição	ØFuro
A	1	2 1/2"	40		ENTRADA DE ÓLEO	79
B	1	2 1/2"	40		SAÍDA DE ÓLEO	79
C	2	1/2"	-	3000# - NPT	VENT / ALÍVIO	34
D	2	1/4" - NPT	-	-	VENT / DRENO	-

- NOTAS:
- TODAS AS DIMENSÕES ESTÃO EM MILÍMETROS, EXCETO ONDE INDICADO.
 - MARCAR LINHAS DE CENTRO HORIZONTAIS E VERTICAIS NO VASO PARA REFERÊNCIA NA MONTAGEM.
 - TODAS AS CONEXÕES FORNECIDAS COM TAMPAS TEMPORÁRIAS. AS TAMPAS TEMPORÁRIAS DEVEEM SER REMOVIDAS ANTES DA OPERAÇÃO.
 - A MONTAGEM DEVE ESTAR LIMPA, LIVRE DE REBARBAS, CAREPAS E RESPINGOS DE SOLDAS.
 - QUEBRAR TODOS OS CANTOS E ARESTAS.
 - SEQUÊNCIA DE APERTO DOS PARAFUSOS DA TAMPA CONFORME ABAIXO:
 - APERTO DE MÃO
 - TORQUEAR OS PARAFUSOS COM 70 FT-LB (95 N-m)
 - TORQUEAR OS PARAFUSOS COM 145 FT-LB (197 N-m)
 - O ITEM 553E0013G99BR É MONTADO APENAS COM AS PEÇAS MARCADAS COM UM "X" NA LISTA DE PEÇAS, ESSE ITEM É UM SEMI ACABADO DOS CONJUNTOS G02 E G03.

HISTÓRICO DE REVISÕES									
QUADR.	REV.	ECN/NAE	DESCRIÇÃO DA REVISÃO	DES.	DATA DES.	VER.	DATA VER.	APR.	DATA APR.
-	2	BR20-0171	ALT. POS. 9 E 10 PARA ESTRUTURA G99	LFH	21/08/2020	FAR	21/08/2020	AA	21/08/2020
-	1	BR20-0156	ATUALIZADO REVISÃO DA TOLERÂNCIA	AA	10/08/2020	FAR	10/08/2020	LRM	10/08/2020
-	0		EMIÇÃO INICIAL	GCS	29/01/2020	AA	29/01/2020	LRM	29/01/2020

CLIENTE:	TÍTULO:
Nº PEDIDO:	FILTRO DE ÓLEO (PADRÃO)
PROJETO:	ELEMENTO COMPRIMENTO 43"
FORMATO: A1	ESCALA: 1:5
SUBSTITUI DESENHO:	CONEXÕES DN.2 1/2"
ACABAMENTO E TOLERÂNCIA CONF.: 17-00.213-BE-BR	
Johnson Controls	DES. Nº.: 553E0014BR
REV.: 2	FOLHA Nº. 1 / 1



**JOHNSON CONTROLS
BE DO BRASIL LTDA**

AV. INDEPENDÊNCIA, 2757 - IPORANGA
SOROCABA/SP - 18087-101
CNPJ: 01.092.686/0023-66

EQUIPAMENTO	UNIDADE COMPRESSORA			
MODELO	RWF II 399	ANO DE FABR.	2021	
NÚMERO DE SÉRIE	322102	TAG		
CARGA DE ÓLEO (I)	492	REFRIGERANTE	R717	
PESO (kgf) TRANSPORTE	5818	OPERAÇÃO	6239	
POTÊNCIA INSTALADA (KW)	220	REGIME (°C)	-46/-10	
TENSÃO (V) FORÇA	380	COMANDO	220	
Nº REGISTRO CREA:	5069876228			

NOTAS:

- 1- ESSE DESENHO CONTÉM APENAS OS DADOS PARA PREENCHIMENTO DA PLAQUETA, PARA CONFECCÃO
VER DESENHO Nº 2516C235

QUADR.	REV.	DESCRIÇÃO DA REVISÃO	DES.	DATA DES.	VER.	DATA VER.	APR.	DATA APR.
-	0	EMISSÃO INICIAL	LRM	03/09/2021	FAR	03/09/2021	AA	03/09/2021
HISTÓRICO DE REVISÕES								
CLIENTE: MARFRIG BATAGUASSU			TÍTULO:					
Nº PEDIDO: 32107D.026			PREENCHIMENTO PARA PLAQUETA UNIDADES DIVERSAS 88X127X0,5MM - INOX PORTUGUÊS - NR12					
PROJETO:								
FORMATO: A4		ESCALA: 1/1						
SUBSTITUI DESENHO: ACABAMENTO E TOLERÂNCIAS CONF.: 17-00.213-BE-BR								
 Industrial Refrigeration Latin America Av. Independência, 2757 Sorocaba SP, Brasil			DES. Nº.: 322102			REV.: 0		FOLHA Nº 1/1



**JOHNSON CONTROLS
BE DO BRASIL LTDA**

EQUIPAMENTO	SEPARADOR DE ÓLEO HORIZONTAL		
MODELO	HOS-36	ANO DE FABR.	2021
NÚMERO DE SÉRIE	367258	TAG	

	CASCO	TUBOS / SERPENTINA	NORMA REFERÊNCIA
FLUÍDO	R717/ÓLEO		ASME VIII DIV. 1 ED. 2019
VOLUME INTERNO	m ³ 2,409		
PMTA / PRESSÃO DE PROJETO	bar(g) 21		CATEGORIA NR-13 A-3-II
PRESSÃO DE TESTE	bar(g) PNEU 23,1		
TEMPERATURA DE PROJETO	°C -29/120		PESO VAZIO (kgf) 2050
MARGEM PARA CORROSÃO	mm 0		
EFICIÊNCIA DE SOLDA	0,7		
ALÍVIO DE TENSÃO	NÃO		

NOTAS:

- 1- ESSE DESENHO CONTÉM APENAS OS DADOS PARA PREENCHIMENTO DA PLAQUETA, PARA CONFECCÃO
VER DESENHO Nº 2516C116

-	0	EMIÇÃO INICIAL	LRM	03/09/2021	FAR	03/09/2021	AA	03/09/2021
QUADR.	REV.	DESCRIÇÃO DA REVISÃO	DES.	DATA DES.	VER.	DATA VER.	APR.	DATA APR.
HISTÓRICO DE REVISÕES								
CLIENTE: MARFRIG BATAGUASSU			TÍTULO:					
Nº PEDIDO: 32107D.026			PREENCHIMENTO PARA PLAQUETA VASOS DE PRESSÃO E TROCADORES 127X127X0,5MM - INOX PORTUGUÊS					
PROJETO:								
FORMATO: A4		ESCALA: 1/1						
SUBSTITUI DESENHO: ACABAMENTO E TOLERÂNCIAS CONF.: 17-00.213-BE-BR								
 Industrial Refrigeration Latin America Av. Independência, 2757 Sorocaba SP, Brasil			DES. Nº.: 367258			REV.: 0		FOLHA Nº 1/1



**JOHNSON CONTROLS
BE DO BRASIL LTDA**

EQUIPAMENTO	FILTRO DE ÓLEO		
MODELO	FO CX 2 1/2	ANO DE FABR.	2021
NÚMERO DE SÉRIE	391216	TAG	

	CASCO	TUBOS / SERPENTINA	NORMA REFERÊNCIA
FLUÍDO	R717/ÓLEO		ASME VIII DIV. 1 ED. 2019
VOLUME INTERNO	m ³ 0,043		
PMTA / PRESSÃO DE PROJETO	bar(g) 28		CATEGORIA NR-13 A-5-III
PRESSÃO DE TESTE	bar(g) PNEU 31		
TEMPERATURA DE PROJETO	°C -29/120		PESO VAZIO (kgf) 91
MARGEM PARA CORROSÃO	mm 0		
EFICIÊNCIA DE SOLDA	0,85		
ALÍVIO DE TENSÃO	NÃO		

NOTAS:

- 1- ESSE DESENHO CONTÉM APENAS OS DADOS PARA PREENCHIMENTO DA PLAQUETA, PARA CONFECCÃO
VER DESENHO Nº 2516C116

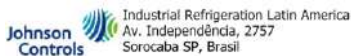
-	0	EMIÇÃO INICIAL	LRM	03/09/2021	FAR	03/09/2021	AA	03/09/2021
QUADR.	REV.	DESCRIÇÃO DA REVISÃO	DES.	DATA DES.	VER.	DATA VER.	APR.	DATA APR.
HISTÓRICO DE REVISÕES								
CLIENTE: MARFRIG BATAGUASSU			TÍTULO:					
Nº PEDIDO: 32107D.026			PREENCHIMENTO PARA PLAQUETA VASOS DE PRESSÃO E TROCADORES 127X127X0,5MM - INOX PORTUGUÊS					
PROJETO:								
FORMATO: A4		ESCALA: 1/1						
SUBSTITUI DESENHO: ACABAMENTO E TOLERÂNCIAS CONF.: 17-00.213-BE-BR								
 Industrial Refrigeration Latin America Av. Independência, 2757 Sorocaba SP, Brasil			DES. Nº.: 391216			REV.: 0		FOLHA Nº 1/1



**JOHNSON CONTROLS
BE DO BRASIL LTDA**

EQUIPAMENTO	FILTRO DE ÓLEO		
MODELO	FO CX 2 1/2	ANO DE FABR.	2021
NÚMERO DE SÉRIE	391217	TAG	

	CASCO	TUBOS / SERPENTINA	NORMA REFERÊNCIA
FLUÍDO	R717/ÓLEO		ASME VIII DIV. 1 ED. 2019
VOLUME INTERNO	m ³ 0,043		
PMTA / PRESSÃO DE PROJETO	bar(g) 28		CATEGORIA NR-13 A-5-III
PRESSÃO DE TESTE	bar(g) PNEU 31		
TEMPERATURA DE PROJETO	°C -29/120		PESO VAZIO (kgf) 91
MARGEM PARA CORROSÃO	mm 0		
EFICIÊNCIA DE SOLDA	0,85		
ALÍVIO DE TENSÃO	NÃO		

NOTAS:

- 1- ESSE DESENHO CONTÉM APENAS OS DADOS PARA PREENCHIMENTO DA PLAQUETA, PARA CONFECCÃO
VER DESENHO Nº 2516C116

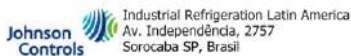
-	0	EMIÇÃO INICIAL	LRM	03/09/2021	FAR	03/09/2021	AA	03/09/2021
QUADR.	REV.	DESCRIÇÃO DA REVISÃO	DES.	DATA DES.	VER.	DATA VER.	APR.	DATA APR.
HISTÓRICO DE REVISÕES								
CLIENTE: MARFRIG BATAGUASSU			TÍTULO:					
Nº PEDIDO: 32107D.026			PREENCHIMENTO PARA PLAQUETA VASOS DE PRESSÃO E TROCADORES 127X127X0,5MM - INOX PORTUGUÊS					
PROJETO:								
FORMATO: A4		ESCALA: 1/1						
SUBSTITUI DESENHO: ACABAMENTO E TOLERÂNCIAS CONF.: 17-00.213-BE-BR								
 Industrial Refrigeration Latin America Av. Independência, 2757 Sorocaba SP, Brasil			DES. Nº.: 391217			REV.: 0		FOLHA Nº 1/1



3) IDENTIFICAÇÃO E CERTIFICADOS DE MATÉRIA-PRIMA IDENTIFICATION AND CERTIFICATES OF MATERIAL



LISTA IDENTIFICAÇÃO DE MATÉRIA-PRIMA

Cliente: MARFRIG GLOBAL FOODS S.A.
Produto: UNIDADE COMPRESSORA PARAFUSO RWF 399
Item: E-32107D.026-01
Série: 322102
Caldereiro -

EQUIPAMENTO	DESENHO	POS.	COMPONENTE	MATERIAL	DIMENSÕES	Nº CERTIFICADO	Nº VOLUME	Nº CORRIDA	RASTREABILIDADE
RWF 399	4847CF399-032	-	Válvula	-	300 PSI	179614	-	-	179614
		-	Válvula	-	300 PSI	179615	-	-	179615
		-	Manovac	-	1/2" BSP	125652	-	-	125652
		-	Manovac	-	1/2" BSP	125789	-	-	125789
		-	Manovac	-	1/2" BSP	125795	-	-	125795
367259 - SO7664	548E0406G31BR	01	Casco	A 516	12,5mm	8126067516	3025260004	27117134	CH 023-21
		02	Fundos abaulado	A 516	12,5mm	8126067516	3025260004	27117134	CH 023-21
		05	Selas	A 516	12,5mm	8131850466	3130196301	27120635	CH 045-21
		13	Flange	A 105	8"	40382201	-	11907953	11907953
		16	Tubo	A 106	8"	0050768186	-	190166	TB 059-21
		20	Luva	A 105	2"	40526701	-	BTM	BTM
		26	Luva	A 105	1/2"	40527406	-	070H	070H
		28	Luva	A 106	2.1/2"	0050739775	-	185654	TB 060-21
		32	Tubo	A 106	1"	0050756585	-	188581	TB 011-21
		36	Tubo	A 106	6"	0030049222	-	191452	TB 075-21
		37	Tubo	A 516	37,50mm	5331241	850358917	434046	CH 028-21
		39	Olhal	A 516	6,3mm	8109786527	-	2809070	CH 029-21
		44	Sela	A 106	3/4"	293710	-	187394	187394
		45	Tubo	A 105	3/4"	40607905	-	BJB	BJB
		53	Sela	A 516	6,3mm	8109786527	-	2809070	CH 029-21
55	Sela	A 516	6,3mm	8109786527	-	2809070	CH 029-21		
59	Sela	A 516	6,3mm	8109786527	-	2809070	CH 029-21		
391218 - FO1149 / 391219 - FO1150	553E0014BR	01	Casco	A 106	9,5mm	0050771819	-	190167	TB 095-21
		02	Fundos abaulado	A 106	9,5mm	0050771819	-	190167	TB 095-21
		08/10	Tubo	A 106	2.1/2"	0050780243	-	191377	TB 104-21
		11	Luva	A 105	1/2"	40527406	-	070H	070H
		03	Flange	A 516	37,50mm	5331241	850358917	434046	CH 028-21

CYRUS SHANK COMPANY

4645 W. Roosevelt Road
Cicero, Illinois 60804
Phone: (708) 652-2700 Fax: (708) 652-2766
Website Address: www.cyrusshank.com

RELIEF VALVE CERTIFICATION

This valve is certified to have been manufactured, assembled, and tested to meet the requirements of ASME Boiler & Pressure Vessel Code, Section VIII, Division I, Part UG.

All construction materials are ASME approved materials.

ASME Certificate of Authorization for UV Symbol #28,745.

ASME Pressure Relief Device Relieving Capacity Certification
#SHK-M51141
813 (1/2" X 1") 300# Relief Valve

S/N # 179614

Attested To:

Franciszek Kosk
Franciszek Kosk, Valve Department Manager

Benjamin Chandler
Benjamin Chandler, Engineer

Date: 6/21/2021

JOHNSON CONTROLS	
Supplier:	AL PLATES
MR: 85457	DATE: 23/07/21
MR: 179614	REF: 952A00514105
SA:	Ed: 2019
Inspector: <u>e</u>	

CYRUS SHANK COMPANY

4645 W. Roosevelt Road

Cicero, Illinois 60804

Phone: (708) 652-2700 Fax: (708) 652-2766

Website Address: www.cyrusshank.com

RELIEF VALVE CERTIFICATION

This valve is certified to have been manufactured, assembled, and tested to meet the requirements of ASME Boiler & Pressure Vessel Code, Section VIII, Division 1, Part UG.

All construction materials are ASME approved materials.

ASME Certificate of Authorization for UV Symbol #28,745.

ASME Pressure Relief Device Relieving Capacity Certification

#SHK-M51141

813 (1/2" X 1") 300# Relief Valve

S/N # 179615

Attested To:

Franciszek Kosk
Franciszek Kosk, Valve Department Manager

Benjamin Chandler
Benjamin Chandler, Engineer

Date: 6/21/2021

JOHNSON CONTROLS	
Fornecedor: ALPATEX	
YR: 84457	D: 22/07/21
NR: 179615	952 A0051 HLOS
SA	2021 Ad:
Inspector: [Signature]	



WILLY
Certificado de Calibração
Calibration Certificate
Certificado de Calibración

Nº 125652

Calibração
 NBR ISO/IEC
 17025



Rede Brasileira de Calibração - Laboratório acreditado pela Cgcre - Sob o nº 015
 Brazilian Calibration Network - Laboratory accredited by Cgcre - Under nº 015
 Red Brasileña de Calibración - Laboratorio acreditado por Cgcre - Bajo nº 015

Requerente / Customer Name / Cliente :
 Endereço / Address / Dirección :
 Ordem de Serviço / Customer Order Nº :

JOHNSON CONTROLS BE DO BRASIL LTDA
 RUA JOAO TIBIRICA 900 VL ANASTACIO SAO PAULO SP
 1W3847.01

CARACTERÍSTICA SPECIFICATION CARACTERÍSTICA	INSTRUMENTO EM TESTE INSTRUMENT INSTRUMENTO EN PRUEBA	PADRÃO UTILIZADO MASTER PATRÓN UTILIZADO
Modelo / Fabricante Model / Manufacturer Modelo / Fabricante	PB1N 114/1 1/2 BSP XGL XOS XDA / WILLY	AQS-2/ASHCROFT
Nº de Série Serial Number Nº de Serie	AQS-30147
Identificação Identification Identificación	2.17.005
Tipo / Type	Manômetro Analógico \ Analog Pressure Gauge	Manômetro Digital \ Digital Pressure Gauge
Faixa de Indicação Range	-1 / 21 bar	0 / 500 psi
Valor de Uma Divisão / Resolução Minor Interval / Resolution	0,2 bar	0,01 psi
Cada Divisão / Resolución Índice da Classe Accuracy Class	1 %FE	0,01 %FE
Certificado / Validade do Certificado Certificate / Calibration Due Date Origen y Validad del Certificado	RBC WILLY 122867 ago -2021

Valor Indicado (Instrumento em Teste) Indication (Instrument under test) Valor Indicado (Instrumento en Prueba)		Valor de Referência (Padrão Utilizado) Reference Value (Master) bar Valor de Referência (Patrón Utilizado)			
MPa	bar	1º Ciclo / 1 st Cycle		2º Ciclo / 2 nd Cycle	
		Carregamento Increasing	Descarregamento Decreasing	Carregamento Increasing	Descarregamento Decreasing
0,00	0,0	0,000	0,000	0,000	0,000
0,30	3,0	3,080	2,912	2,988	2,923
0,90	9,0	9,132	8,990	9,080	8,966
1,50	15,0	15,137	15,014	15,137	14,998
2,10	21,0	21,134	21,134	21,111	21,111

Fator de Conversão (S.I.) / Factor de Conversión / Conversion Factor : 1 MPa = 1,000000E+01 bar

Características Apresentadas Pelo Instrumento Em Teste / Instrument Results / Características Presentadas Por El Instrumento Em Prueba	
Índice da Classe / Accuracy / Índice de Classe : 0,62 %FE	Incerteza da Medição / Incertidumbre de Medición / Uncertainty of Measurement : 0,60 %FE
Histerese / Hysteresis / Histerese : 0,77 %FE	Temperatura Ambiente / Room Temperature : 21 °C
Repetibilidade / Repeatability / Repetibilidad : 0,42 %FE	Umidade Relativa / Relative Humidity / Humedad Relative : 57 %

OBSERVAÇÕES / NOTES / NOTAS :
 A incerteza expandida de medição relatada é declarada como a incerteza padrão da medição multiplicada pelo fator de abrangência k, de tal forma que a probabilidade de abrangência corresponda a aproximadamente 95%.
 The informed extended uncertainty is declared as standard uncertainty multiplied by coverage factor k, in order to have comprehensiveness of 95%.
 La incertidumbre de medición reportada es declarada como la incertidumbre patrón de la medición multiplicada por el factor k de manera que la probabilidad de la integralidad sea aproximadamente 95%.

Curva de Correção: Y=(1,0065) .X +(-0,0203); Y=valor corrigido e X=pressão indicada no instrumento. Incerteza da medição para um nível de confiança de 95,45%, k=2,14
 Calibration curve: Y=(1,0065) .X + (-0,0203); Y=corrected value and X=indicated value (instrument). Uncertainty for 95,45% of confidence level, coverage factor k=2,14
 Curva de Corrección: Y=(1,0065)X +(-0,0203); Y=valor corrigido e X=valor indicado. Incertidumbre de medición para un nivel de confiabilidad de 95,45%, factor k=2,14

JOHNSON CONTROLS
 WILLY
 DATA: 31/08/2021
 ITEM: 15418815
 NBR: 125652
 Em conformidade com a ASME
 Ed: Ad:
 Inspetor: Pacatimato



Analista da Qualidade: Francisco P. Santana
 Aprovado / Aprobado / Approval

Data / Fecha / Date: 14-ago-2021
 Folha / Hoja / Sheet: 1 / 2

Calibração em 2 ciclos (carregamento e descarregamento). Cada valor indicado no Instrumento em Teste, o valor de referência é lido no Padrão, conforme Procedimento Q-2040-007)
 Este certificado é válido para a escala / unidade utilizada na calibração. Esta calibração não isenta o Instrumento do controle Metroológico estabelecido na Regulamentação
 Este certificado somente é válido exclusivamente para o Instrumento submetido à calibração, nas condições especificadas, não sendo extensivo a quaisquer lotes.
 Este certificado atende aos Requisitos de Acreditação Cgcre, que avaliou a competência do Laboratório e comprovou sua Rastreabilidade aos Padrões Nacionais de medida.
 O serviço de conserto e ajustes no Instrumento em Teste, não faz parte do Escopo de Acreditação deste Laboratório. O certificado não deve ser parcialmente reproduzido.
 This Certificate is valid, exclusively for the tested instrument, under specified test conditions. Partial certificate reproduction is prohibited.
 This Certificate is in conformity with Cgcre requirements accreditation, who has approved the laboratory competence and the traceability to Brazilian masters.
 This calibration does not exempt the instrument of usual metrological control established by metrological regulations.
 Este certificado solo es valido, exclusivamente para el Instrumento sometido a la calibración, en las condiciones especificadas, no sirviendo a cualesquier lotes.
 Este certificado atende a los requisitos de acreditación de Cgcre, lo cual evaluó la capacidad del Laboratorio y comprobó su rastreabilidad a los patrones de medidas.
 Esta calibración no exenta el Instrumento del control metrologico establecido en la reglamentación metrologica.
 El certificado no debe ser parcialmente reproducido.

Laboratório de Metrologia da Willy Instrumentos de Medição e Controle Ltda.
 Uma empresa ASHCROFT® Inc.

Rua João Pessoa, 620 - Centro - São Caetano do Sul - SP - Brasil - Tel.: (65 11) 4224-7400 - Fax: (65 11) 4224-7477 - E-mail: vendas@ashcroft.com - Site: www.ashcroft.com.br



WILLY
Certificado de Calibração
Calibration Certificate
Certificado de Calibración

N° 125652

Calibração
 NBR ISO/IEC
 17025



Rede Brasileira de Calibração - Laboratório acreditado pela Cgcre - Sob o n° 015
 Brazilian Calibration Network - Laboratory accredited by Cgcre - Under n° 015
 Red Brasileña de Calibración - Laboratorio acreditado por Cgcre - Bajo n° 015

Requerente / Customer Name / Cliente :
 Endereço / Address / Dirección :
 Ordem de Serviço / Customer Order N° :

JOHNSON CONTROLS BE DO BRASIL LTDA
 RUA JOAO TIBIRICA 900 VL ANASTACIO SAO PAULO SP
 1W3847.01

CARACTERÍSTICA SPECIFICATION CARACTERÍSTICA	INSTRUMENTO EM TESTE INSTRUMENT INSTRUMENTO EN PRUEBA	PADRÃO UTILIZADO MASTER PATRÓN UTILIZADO
Modelo / Fabricante Model / Manufacturer Modelo / Fabricante	PBIN 114/1 1/2 BSP XGL XOS XDA / WILLY	AQS-2 / ASHCROFT
N° de Série Serial Number N° de Série	AQS-62338
Identificação Identification Identificación	2.17.048 (vácuo)
Tipo / Type	Manômetro Analógico \ Analog Pressure Gauge	Manômetro Digital \ Digital Pressure Gauge
Faixa de Indicação Range	-76 / 1575 cmHg	-15 / 15 psi
Rango de Indicación		
Valor de Uma Divisão / Resolução Minor Interval / Resolution	19 cmHg	0,001 psi
Cada División / Resolución Índice da Classe Accuracy Class	1 %FE	0,02 %FE
Índice da Classe Certificado / Validade do Certificado Certificate / Calibration Due Date Origen y Validad del Certificado	RBC WILLY 124645 2 de 2 DEZ-2021

Valor Indicado (Instrumento em Teste) Indication (Instrument under test) Valor Indicado (Instrumento em Prueba)		Valor de Referência (Padrão Utilizado) Reference Value (Master) Valor de Referência (Patrón Utilizado)			
MPa	cmHg	1° Ciclo / 1 st Cycle		2° Ciclo / 2 nd Cycle	
		Carregamento Increasing	Descarregamento Decreasing	Carregamento Increasing	Descarregamento Decreasing
0.00	0	-0.01	-0.01	-0.01	-0.01
-0.05	-40	-39.98	-39.51	-40.00	-39.47
-0.07	-50	-50.08	-50.08	-50.10	-50.10

Fator de Conversão (S.I) / Factor de Conversión / Conversion Factor : 1 MPa = 7,514200E+02 cmHg (referencia a 20°C)

Características Apresentadas Pelo Instrumento Em Teste / Instrument Results / Características Presentadas Por El Instrumento Em Prueba	
Índice da Classe / Accuracy / Índice de Classe: 0,03 %FE	Incerteza da Medição / Incertidumbre de Medición / Uncertainty of Measurement: 0,78 %FE
Histerese / Hysteresis / Histerese: 0,03 %FE	Temperatura Ambiente / Room Temperature: 21 °C
Repetibilidade / Repeatability / Repetibilidad : 0,00 %FE	Umidade Relativa / Relative Humidity / Humedad Relativo: 57 %

OBSERVAÇÕES / NOTES / NOTAS :

A incerteza expandida de medição relatada é declarada como a incerteza padrão da medição multiplicada pelo fator de abrangência k, de tal forma que a probabilidade de abrangência corresponda a aproximadamente 95%.

The informed extended uncertainty is declared as standard uncertainty multiplied by coverage factor k, in order to have comprehensiveness of 95%.

La incertidumbre de medición reportada es declarada como la incertidumbre patrón de la medición multiplicada por el factor k de manera que la probabilidad de la integralidad sea aproximadamente 95%.

Curva de Correção: Y=(0,9993) .X +(0,0337); Y =valor corrigido e X =pressão indicada no instrumento. Incerteza da medição para um nível de confiança de 95,45%, k= 2,00

Calibration curve: Y = (0,9993). X + (0,0337); Y =corrected value and X = indicated value (instrument). Uncertainty for 95,45% of confidence level, coverage factor k =2,00

Curva de Corrección: Y= (0,9993)X +(0,0337); Y =valor corrigido e X =valor indicado. Incertidumbre de medición para un nivel de confiabilidad de 95,45%, factor k =2,00



Analista da Qualidade: Francisco P. Santana
 Aprovado / Aprobado / Approval

Data / Fecha / Date: 14-ago-2021
 Folha / Hoja / Sheet: 2 / 2

Q-2040-009 E - Fev/17

Calibração em 2 ciclos (carregamento e descarregamento). Cada valor indicado no Instrumento em Teste, o valor de referência é lido no Padrão, conforme Procedimento Q-2040-007. Este certificado é válido para a escala / unidade utilizada na calibração. Esta calibração não isenta o Instrumento do controle Metroológico estabelecido na Regulamentação. Este certificado somente é válido exclusivamente para o Instrumento submetido à calibração, nas condições especificadas, não sendo extensivo a quaisquer lotes. Este certificado atende aos Requisitos de Acreditação Cgcre, que avaliou a competência do Laboratório e comprovou sua Rastreabilidade aos Padrões Nacionais de medida. O serviço de conserto e ajustes no Instrumento em Teste, não faz parte do Escopo de Acreditação deste Laboratório. O certificado não deve ser parcialmente reproduzido.

This Certificate is valid, exclusively for the tested instrument, under specified test conditions. Partial certificate reproduction is prohibited.

This Certificate is in conformity with Cgcre requirements accreditation, who has approved the laboratory competence and the traceability to Brazilian masters.

This calibration does not exempt the instrument of usual metrological control established by metrological regulations.

Este certificado solo es valido, exclusivamente para el Instrumento sometido a la calibración, en las condiciones especificadas, no sirviendo a cualesquier lotes. Este certificado atende a los requisitos de acreditación de Cgcre, to cual evaluó la capacidad del Laboratorio y comprobó su rastreabilidad a los patrones de medidas. Esta calibración no exenta el instrumento del control metrologico establecido en la reglamentación metrologica.

El certificado no debe ser parcialmente reproducido.

Laboratório de Metrologia da Willy Instrumentos de Medição e Controle Ltda.
 Uma empresa ASHCROFT® Inc.

Rua João Pessoa, 620 - Centro - São Caetano do Sul - SP - Brasil - Tel.: (55 11) 4224-7400 - Fax: (55 11) 4224-7477 - E-mail: vendas@ashcroft.com - Site: www.ashcroft.com.br



WILLY
Certificado de Calibração
Calibration Certificate
Certificado de Calibración

N° 125788

Calibração
NBR ISO/IEC
17025



CAL 0015

Rede Brasileira de Calibração - Laboratório acreditado pela Cgcre - Sob o n° 015
 Brazilian Calibration Network - Laboratory accredited by Cgcre - Under n° 015
 Red Brasileira de Calibración - Laboratorio acreditado por Cgcre - Bajo n° 015

Requerente / Customer Name / Cliente : JOHNSON CONTROLS BE DO BRASIL LTDA
 Endereço / Address / Dirección : RUA JOAO TIBIRICA 900 VL ANASTACIO SAO PAULO SP
 Ordem de Serviço / Customer Order N° : 1W3953.01

CARACTERÍSTICA SPECIFICATION CARACTERÍSTICA	INSTRUMENTO EM TESTE INSTRUMENT INSTRUMENTO EN PRUEBA	PADRÃO UTILIZADO MASTER PATRÓN UTILIZADO
Modelo / Fabricante Model / Manufacturer Modelo / Fabricante	PBIN 114/1 1/2 BSP XGL XOS XDA / WILLY	AQS-2/ASHCROFT
N° de Série Serial Number N° de Serie	AQS-30147
Identificação Identification Identificación	2.17.005
Tipo / Type	Manômetro Analógico \ Analog Pressure Gauge	Manômetro Digital \ Digital Pressure Gauge
Faixa de Indicação Range	-1 / 21 bar	0 / 500 psi
Valor de Uma Divisão / Resolução Minor interval / Resolution	0,2 bar	0,01 psi
Cada Divisão / Resolución Índice da Classe Accuracy Class Índice da Classe	1 %FE	0,01 %FE
Certificado / Validade do Certificado Certificate / Calibration Due Date Origen y Validad del Certificado	RBC WILLY 122867 ago -2021

Valor Indicado (Instrumento em Teste) Indication (Instrument under test) Valor Indicado (Instrumento en Prueba)	Valor de Referência (Padrão Utilizado) Reference Value (Master) Valor de Referência (Patrón Utilizado)				
	1° Ciclo / 1 st Cycle		2° Ciclo / 2 nd Cycle		
	Carregamento Increasing	Descarregamento Decreasing	Carregamento Increasing	Descarregamento Decreasing	
MPa	bar				
0,00	0,0	0,000	0,000	0,000	0,000
0,30	3,0	3,001	2,998	3,004	3,054
0,90	9,0	8,968	9,024	8,987	8,985
1,50	15,0	14,922	14,993	15,000	14,994
2,10	21,0	21,005	21,005	21,023	21,023

Fator de Conversão (S.I) / Factor de Conversión / Conversion Factor : 1 MPa = 1,000000E+01 bar

Características Apresentadas Pelo Instrumento Em Teste / Instrument Results / Características Presentadas Por El Instrumento Em Prueba	
Índice da Classe / Accuracy / Índice de Classe: 0,35 %FE	Incerteza da Medição / Incertidumbre de Medición / Uncertainty of Measurement: 0,42 %FE
Histerese / Hysteresis / Histerese: 0,32 %FE	Temperatura Ambiente / Room Temperature: 21 °C
Repetibilidade / Repeatability / Repetibilidad: 0,36 %FE	Umidade Relativa / Relative Humidity / Humedad Relativa: 56 %

OBSERVAÇÕES / NOTES / NOTAS :

A incerteza expandida de medição relatada é declarada como a incerteza padrão da medição multiplicada pelo fator de abrangência k, de tal forma que a probabilidade de abrangência corresponda a aproximadamente 95%.

The informed extended uncertainty is declared as standard uncertainty multiplied by coverage factor k, in order to have comprehensiveness of 95%.

La incertidumbre de medición reportada es declarada como la incertidumbre patrón de la medición multiplicada por el factor k de manera que la probabilidad de la integridad sea aproximadamente 95%.

Curva de Correção: Y=(0,9998) . X +(0,0008); Y=valor corrigido e X=pressão indicada no instrumento. Incerteza da medição para um nível de confiança de 95,45%, k=2,02

Calibration curve: Y=(0,9998) . X +(0,0008); Y=corrected value and X=indicated value (instrument). Uncertainty for 95,45% of confidence level, coverage factor k=2,02

Curva de Corrección: Y=(0,9998)X +(0,0008); Y=valor corrigido e X=valor indicado. Incertidumbre de medição para um nível de confiabilidade de 95,45%, factor k=2,02



Analista da Qualidade: Francisco P. Santana
 Aprovado / Aprobado / Approval

Data / Fecha / Date: 21-ago-2021
 Folha / Hoja / Sheet: 1 / 2

JOHNSON CONTROLS

Formador: SA
 Ed: SA
 Inspeção: SA
 NR: 0117994-1 DATA: 31/07/21
 NR: 125788 ITEM: 15412915
 Em conformidade com a ASME

Q-2040-008 E - Rev 1/7

Calibração em 2 ciclos (carregamento e descarregamento). Cada valor indicado no Instrumento em Teste, o valor de referência é lido no Padrão, conforme Procedimento Q-2040-007.
 Este certificado é válido para a escala / unidade utilizada na calibração. Esta calibração não isenta o Instrumento do controle Metroológico estabelecido na Regulamentação.
 Este certificado somente é válido exclusivamente para o Instrumento submetido à calibração, nas condições especificadas, não sendo extensivo a quaisquer lotes.
 Este certificado atende aos Requisitos de Acreditação Cgcre, que avaliou a competência do Laboratório e comprovou sua Rastreabilidade aos Padrões Nacionais de medição.
 O serviço de conserto e ajustes no Instrumento em Teste, não faz parte do Escopo de Acreditação deste Laboratório. O certificado não deve ser parcialmente reproduzido.
 This Certificate is valid, exclusively for the tested instrument, under specified test conditions. Partial certificate reproduction is prohibited.
 This Certificate is in conformity with Cgcre requirements accreditation, who has approved the laboratory competence and the traceability to Brazilian masters.
 This calibration does not exempt the instrument of usual metrological control established by metrological regulations.
 Este certificado solo es valido, exclusivamente para el Instrumento sometido a la calibración, en las condiciones especificadas, no sirviendo a cualesquier lotes.
 Este certificado atende a los requisitos de acreditación de Cgcre, lo cual evaluó la capacidad del Laboratorio y comprobó su rastreabilidad a los patrones de medidas.
 Esta calibración no exenta el Instrumento del control metrologico establecido en la reglamentación metrologica.
 El certificado no debe ser parcialmente reproducido.

Laboratório de Metrologia da Willy Instrumentos de Medição e Controle Ltda.
 Uma empresa ASHCROFT[®] Inc.

Rua João Pessoa, 620 - Centro - São Caetano do Sul - SP - Brasil - Tel.: (55 11) 4224-7400 - Fax: (55 11) 4224-7477 - E-mail: vendas@ashcroft.com - Site: www.ashcroft.com.br

Rede Brasileira de Calibração - Laboratório acreditado pela Cgcre - Sob o n° 015
Brazilian Calibration Network - Laboratory accredited by Cgcre - Under n° 015
Red Brasileña de Calibración - Laboratório acreditado por Cgcre - Bajo n° 015

Requerente / Customer Name / Cliente : JOHNSON CONTROLS BE DO BRASIL LTDA
Endereço / Address / Dirección: RUA JOAO TIBIRICA 900 VL ANASTACIO SAO PAULO SP
Ordem de Serviço / Customer Order N° : 1W3953.01

CARACTERÍSTICA SPECIFICATION CARACTERÍSTICA	INSTRUMENTO EM TESTE INSTRUMENT INSTRUMENTO EN PRUEBA	PADRÃO UTILIZADO MASTER PATRÓN UTILIZADO
Modelo / Fabricante Model / Manufacturer Modelo / Fabricante	PB1N 114/1 1/2 BSP XGL XOS XDA / WILLY	AQS-2 / ASHCROFT
N° de Série Serial Number N° de Serie		AQS-62338 2.17.048 (vácuo)
Identificação Identification Identificación		
Tipo / Type	Manômetro Analógico \ Analog Pressure Gauge	Manômetro Digital \ Digital Pressure Gauge
Faixa de Indicação Range	-76 / 1575 cmHg	-15 / 15 psi
Ranço de Indicação Valor de Uma Divisão / Resolução Minor Interval / Resolution	19 cmHg	0,001 psi
Cada Divisão / Resolução Índice da Classe Accuracy Class Índice da Clase	1 %FE	0,02 %FE
Certificado / Validade do Certificado Certificate / Calibration Due Date Origen y Validad del Certificado		RBC WILLY 124645 2 de 2 DEZ-2021

Valor Indicado (Instrumento em Teste) Indication (Instrument under test) Valor Indicado (Instrumento em Prueba)		Valor de Referência (Padrão Utilizado) Reference Value (Master) Valor de Referência (Patrón Utilizado)			
MPa	cmHg	1º Ciclo / 1 st Cycle		2º Ciclo / 2 nd Cycle	
		Carregamento Increasing	Descarregamento Decreasing	Carregamento Increasing	Descarregamento Decreasing
0.00	0	-0.01	-0.01	-0.01	-0.01
-0.05	-40	-40.00	-40.10	-39.97	-39.55
-0.07	-50	-50.22	-50.22	-50.22	-50.22

Fator de Conversão (S.I) / Factor de Conversión / Conversion Factor : 1 MPa = 7,514200E+02 cmHg (referencia a 20°C)

Características Apresentadas Pelo Instrumento Em Teste / Instrument Results / Características Presentadas Por El Instrumento Em Prueba	
Índice da Classe / Accuracy / Índice de Classe: 0,03 %FE	Incerteza da Medição / Incertidumbre de Medición / Uncertainty of Measurement: 0,70 %FE
Histerese / Hysteresis / Histerese: 0,03 %FE	Temperatura Ambiente / Room Temperature: 21 °C
Repetibilidade / Repeatability / Repetibilidad: 0,03 %FE	Umidade Relativa / Relative Humidity / Humedad Relative: 56 %

OBSERVAÇÕES / NOTES / NOTAS :

A incerteza expandida de medição relatada é declarada como a incerteza padrão da medição multiplicada pelo fator de abrangência k, de tal forma que a probabilidade de abrangência corresponda a aproximadamente 95%.

The informed extended uncertainty is declared as standard uncertainty multiplied by coverage factor k, in order to have comprehensiveness of 95%.

La incertidumbre de medición reportada es declarada como la incertidumbre patrón de la medición multiplicada por el factor k de manera que la probabilidad de la integridad sea aproximadamente 95%.

Curva de Correção: $Y = (1,0023) \cdot X + (0,0266)$; Y = valor corrigido e X = pressão indicada no instrumento. Incerteza da medição para um nível de confiança de 95,45%, k= 2,00

Calibration curve: $Y = (1,0023) \cdot X + (0,0266)$; Y = corrected value and X = indicated value (instrument). Uncertainty for 95,45% of confidence level, coverage factor k = 2,00

Curva de Corrección: $Y = (1,0023) \cdot X + (0,0266)$; Y = valor corrigido e X = valor indicado. Incertidumbre de medición para un nivel de confiabilidad de 95,45%, factor k = 2,00



Analista da Qualidade: Francisco P. Santana
Aprovado / Aprobado / Approval

Data / Fecha / Date: 21-ago-2021
Folha / Hoja / Sheet: 2 / 2

Calibração em 2 ciclos (carregamento e descarregamento). Cada valor indicado no Instrumento em Teste, o valor de referência é lido no Padrão, conforme Procedimento Q-2040-007)

Este certificado é válido para a escala / unidade utilizada na calibração. Esta calibração não isenta o instrumento do controle Metroológico estabelecido na Regulamentação

Este certificado somente é válido exclusivamente para o instrumento submetido à calibração, nas condições especificadas, não sendo extensivo a quaisquer lotes.

O serviço de conserto e ajustes no Instrumento em Teste, não faz parte do Escopo de Acreditação deste Laboratório. O certificado não deve ser parcialmente reproduzido.

This Certificate is valid, exclusively for the tested instrument, under specified test conditions. Partial certificate reproduction is prohibited.

This Certificate is in conformity with Cgcre requirements accreditation, who has approved the laboratory competence and the traceability to Brazilian masters.

This calibration does not exempt the instrument of usual metrological control established by metrological regulations.

Este certificado solo es valido, exclusivamente para el Instrumento sometido a la calibración, en las condiciones especificadas, no sirviendo a cualesquier lotes.

Este certificado atende a los requisitos de Acreditación de Cgcre, lo cual evaluó la capacidad del Laboratorio y comprobó su rastreabilidad a los patrones de medidas.

Esta calibración no exenta el Instrumento del control metrologico establecido en la reglamentación metrologica.

El certificado no debe ser parcialmente reproducido.

Laboratório de Metrologia da Willy Instrumentos de Medição e Controle Ltda.

Uma empresa ASHCROFT® Inc.

Rua João Pessoa, 620 - Centro - São Caetano do Sul - SP - Brasil - Tel.: (55 11) 4224-7400 - Fax: (55 11) 4224-7477 - E-mail: vendas@ashcroft.com - Site: www.ashcroft.com.br



Certificado de Calibração
Calibration Certificate
Certificado de Calibración

N° 125795

Calibração
NBR ISO/IEC
17025



Rede Brasileira de Calibração - Laboratório acreditado pela Cgcre - Sob o n° 015
Brazilian Calibration Network - Laboratory accredited by Cgcre - Under n° 015
Red Brasileña de Calibración - Laboratorio acreditado por Cgcre - Bajo n° 015

Requerente / Customer Name / Cliente :
Endereço / Address / Dirección :
Ordem de Serviço / Customer Order N° :

JOHNSON CONTROLS BE DO BRASIL LTDA
RUA JOAO TIBIRICA 900 VL ANASTACIO SAO PAULO SP
1W3953.01

CARACTERÍSTICA SPECIFICATION CARACTERÍSTICA	INSTRUMENTO EM TESTE INSTRUMENT INSTRUMENTO EN PRUEBA	PADRÃO UTILIZADO MASTER PATRÓN UTILIZADO	
Modelo / Fabricante Model / Manufacturer Modelo / Fabricante	PBIN 114/1 1/2 BSP XGL XOS XDA / WILLY	AQS-2/ASHCROFT	
N° de Série Serial Number N° de Serie	AQS-30147	2.17.005
Identificação Identification Identificación	
Tipo / Type	Manômetro Analógico \ Analog Pressure Gauge	Manômetro Digital \ Digital Pressure Gauge	
Faixa de Indicação Range	-1 / 21 bar	0 / 500 psi	
Rango de Indicación	
Valor de Uma Divisão / Resolução Minor Interval / Resolution	0,2 bar	0,01 psi	
Cada División / Resolución	
Índice da Classe Accuracy Class	1 %FE	0,01 %FE	
Certificado / Validade do Certificado Certificate / Calibration Due Date Origen y Validad del Certificado	RBC WILLY 122867	ago -2021

Valor Indicado (Instrumento em Teste) Indication (Instrument under test) Valor Indicado (Instrumento em Prueba)		Valor de Referência (Padrão Utilizado) Reference Value (Master) Valor de Referência (Patrón Utilizado)			
MPa	bar	1º Ciclo / 1 st Cycle		2º Ciclo / 2 nd Cycle	
		Carregamento Increasing	Descarregamento Decreasing	Carregamento Increasing	Descarregamento Decreasing
0,00	0,0	0,000	0,000	0,000	0,000
0,30	3,0	2,976	2,881	2,980	3,028
0,90	9,0	8,972	9,050	9,025	9,047
1,50	15,0	14,892	14,997	15,007	15,025
2,10	21,0	20,984	20,984	20,971	20,971

Fator de Conversão (S.I.) / Factor de Conversión / Conversion Factor : 1 MPa = 1,000000E+01 bar

Características Apresentadas Pelo Instrumento Em Teste / Instrument Results / Características Presentadas Por El Instrumento Em Prueba	
Índice da Classe / Accuracy / Índice de Classe: 0,54 %FE	Incerteza da Medição / Incertidumbre de Medición / Uncertainty of Measurement: 0,52 %FE
Histerese / Hysteresis / Histerese: 0,48 %FE	Temperatura Ambiente / Room Temperature: 21 °C
Repetibilidade / Repeatability / Repetibilidad: 0,66 %FE	Umidade Relativa / Relative Humidity / Humedad Relative: 56 %

OBSERVAÇÕES / NOTES / NOTAS :

A incerteza expandida de medição relatada é declarada como a incerteza padrão da medição multiplicada pelo fator de abrangência k, de tal forma que a probabilidade de abrangência corresponda a aproximadamente 95%.

The informed extended uncertainty is declared as standard uncertainty multiplied by coverage factor k, in order to have comprehensiveness of 95%.

La incertidumbre de medición reportada es declarada como la incertidumbre patrón de la medición multiplicada por el factor k de manera que la probabilidad de la integralidad sea aproximadamente 95%.

Curva de Correção: Y=(0,9995) .X +(-0,0056); Y=valor corrigido e X=pressão indicada no instrumento. Incerteza da medição para um nível de confiança de 95,45%, k=2,09

Calibration curve: Y=(0,9995) .X +(-0,0056); Y=corrected value and X=indicated value (instrument). Uncertainty for 95,45% of confidence level, coverage factor k=2,09

Curva de Corrección: Y=(0,9995)X +(-0,0056); Y=valor corrigido e X=valor indicado. Incertidumbre de medición para un nivel de confiabilidad de 95,45%, factor k=2,09



Analista de Qualidade: Francisco P. Santana
Aprovado / Aprobado / Approval

Data / Fecha / Date: 21-ago-2021
Folha / Hoja / Sheet: 1 / 2

Calibração em 2 ciclos (carregamento e descarregamento). Cada valor indicado no Instrumento em Teste, o valor de referência é lido no Padrão, conforme Procedimento Q-2040-007.
Este certificado é válido para a escala / unidade utilizada na calibração. Esta calibração não isenta o Instrumento do controle Metrológico estabelecido na Regulamentação.
Este certificado somente é válido exclusivamente para o Instrumento submetido à calibração, nas condições especificadas, não sendo extensivo a quaisquer lotes.
Este certificado atende aos Requisitos de Acreditação Cgcre, que avaliou a competência do Laboratório e comprovou sua Rastreabilidade aos Padrões Nacionais de medida.
O serviço de conserto e ajustes no Instrumento em Teste, não faz parte do Escopo de Acreditação deste Laboratório. O certificado não deve ser parcialmente reproduzido.

This Certificate is valid, exclusively for the tested instrument, under specified test conditions. Partial certificate reproduction is prohibited.
This certificate is in conformity with Cgcre requirements accreditation, who has approved the laboratory competence and the traceability to Brazilian masters.
This calibration does not exempt the instrument of usual metrological control established by metrological regulations.

Este certificado solo es valido, exclusivamente para el Instrumento sometido a la calibración, en las condiciones especificadas, no sirviendo a cualesquier lotes.
Este certificado atende a los requisitos de acreditación de Cgcre, lo cual evaluó la capacidad del Laboratorio y comprobó su rastreabilidad a los patrones de medidas.
Esta calibración no exenta el Instrumento del control metrológico establecido en la reglamentación metrológica.
El certificado no debe ser parcialmente reproducido.

Laboratório de Metrologia da Willy Instrumentos de Medição e Controle Ltda.
Uma empresa ASHCROFT® Inc.

Rua João Pessoa, 620 - Centro - São Caetano do Sul - SP - Brasil - Tel.: (55 11) 4224-7400 - Fax: (55 11) 4224-7477 - E-mail: vendas@ashcroft.com - Site: www.ashcroft.com.br

JOHNSON CONTROLS

Comprovador: WILLY

NR: 017944-1 DATA: 31/08/21

NR: 125795 ITEM: 1541E9915

Em conformidade com a ASME

SA - Adm. - Adm. - Inspetor

Q-2040-009 E - Rev 1/7

Rede Brasileira de Calibração - Laboratório acreditado pela Cgcre - Sob o n° 015
Brazilian Calibration Network - Laboratory accredited by Cgcre - Under n° 015
Red Brasileña de Calibración - Laboratório acreditado por Cgcre - Bajo n° 015

Requerente / Customer Name / Cliente : JOHNSON CONTROLS BE DO BRASIL LTDA
Endereço / Address / Dirección: RUA JOAO TIBIRICA 900 VL ANASTACIO SAO PAULO SP
Ordem de Serviço / Customer Order N° : 1W3953.01

CARACTERÍSTICA SPECIFICATION CARACTERÍSTICA	INSTRUMENTO EM TESTE INSTRUMENT INSTRUMENTO EN PRUEBA	PADRÃO UTILIZADO MASTER PATRÓN UTILIZADO
Modelo / Fabricante Model / Manufacturer Modelo / Fabricante	PBIN 114/1 1/2 BSP XGL XOS XDA / WILLY	AQS-2 / ASHCROFT
N° de Série Serial Number N° de Serie	AQS-62338 2.17.048 (vácuo)
Tipo / Type	Manômetro Analógico \ Analog Pressure Gauge	Manômetro Digital \ Digital Pressure Gauge
Faixa de Indicação Range	-76 / 1576 cmHg	-15 / 15 psi
Valor de Uma Divisão / Resolução Minor Interval / Resolution	19 cmHg	0,001 psi
Cada Divisão / Resolución Índice da Classe Accuracy Class	1 %FE	0,02 %FE
Certificado / Validade do Certificado Certificate / Calibration Due Date Origen y Validad del Certificado	RBC WILLY 124645 2 de 2 DEZ-2021

Valor Indicado (Instrumento em Teste) Indication (Instrument under test) Valor Indicado (Instrumento em Prueba)		Valor de Referência (Padrão Utilizado) Reference Value (Master) Valor de Referência (Patrón Utilizado)			
MPa	cmHg	1º Ciclo / 1 st Cycle		2º Ciclo / 2 nd Cycle	
		Carregamento Increasing	Descarregamento Decreasing	Carregamento Increasing	Descarregamento Decreasing
0,00	0	-0,01	-0,01	-0,01	-0,01
-0,05	-40	-39,84	-39,77	-40,23	-40,00
-0,07	-50	-50,18	-50,18	-50,15	-50,15

Fator de Conversão (S.I.) / Factor de Conversión / Conversion Factor : 1 MPa = 7,514200E+02 cmHg (referencia a 20°C)

Características Apresentadas Pelo Instrumento Em Teste / Instrument Results / Características Presentadas Por El Instrumento Em Prueba	
Índice da Classe / Accuracy / Índice de Classe: 0,01 %FE	Incerteza da Medição / Incertidumbre de Medición / Uncertainty of Measurement: 0,61 %FE
Historese / Hysteresis / Historese: 0,01 %FE	Temperatura Ambiente / Room Temperature: 21 °C
Repetibilidade / Repeatability / Repetibilidad : 0,02 %FE	Umidade Relativa / Relative Humidity / Humedad Relative: 56 %

OBSERVAÇÕES / NOTES / NOTAS :
A incerteza expandida de medição relatada é declarada como a incerteza padrão da medição multiplicada pelo fator de abrangência k, de tal forma que a probabilidade de abrangência corresponda a aproximadamente 95%.
The informed extended uncertainty is declared as standard uncertainty multiplied by coverage factor k, in order to have comprehensiveness of 95%.
La incertidumbre de medición reportada es declarada como la incertidumbre patrón de la medición multiplicada por el factor k de manera que la probabilidad de la integralidad sea aproximadamente 95%.

Curva de Correção: Y=(1,0020) X +(0,0145); Y=valor corrigido e X=pressão indicada no instrumento. Incerteza da medição para um nível de confiança de 95,45%, k= 2,00
Calibration curve: Y=(1,0020) X +(0,0145); Y=corrected value and X=indicated value (instrument). Uncertainty for 95,45% of confidence level, coverage factor k=2,00
Curva de Corrección: Y=(1,0020)X +(0,0145); Y=valor corrigido e X=valor indicado. Incertidumbre de medición para un nivel de confiabilidad de 95,45%, factor k =2,00



Analista da Qualidade: Francisco P. Santana
Aprovado / Aprobado / Approval

Data / Fecha / Date: 21-ago-2021
Folha / Hoja / Sheet: 2 / 2

C-2040-009 E-Rev.1/17

Calibração em 2 ciclos (carregamento e descarregamento). Cada valor indicado no Instrumento em Teste, o valor de referência é lido no Padrão, conforme Procedimento Q-2040-007. Este certificado é válido para a escala / unidade utilizada na calibração. Esta calibração não isenta o Instrumento do controle Metroológico estabelecido na Regulamentação. Este certificado somente é válido exclusivamente para o Instrumento submetido à calibração, nas condições especificadas, não sendo extensivo a quaisquer lotes. Este certificado atende aos Requisitos de Acreditação Cgcre, que avaliou a competência do Laboratório e comprovou sua Rastreabilidade aos Padrões Nacionais de medida. O serviço de conserto e ajustes no Instrumento em Teste, não faz parte do Escopo de Acreditação deste Laboratório. O certificado não deve ser parcialmente reproduzido.

This Certificate is valid, exclusively for the tested instrument, under specified test conditions. Partial certificate reproduction is prohibited.
This Certificate is in conformity with Cgcre requirements accreditation, who has approved the laboratory competence and the traceability to Brazilian masters.
This calibration does not exempt the instrument of usual metrological control established by metrological regulations.

Este certificado solo es valido, exclusivamente para el Instrumento sometido a la calibración, en las condiciones especificadas, no sirviendo a cualesquier lotes.
Este certificado atende a los requisitos de acreditación de Cgcre, lo cual evaluó la capacidad del Laboratorio y comprobó su rastreabilidad a los patrones de medidas.
Esta calibración no exenta el Instrumento del control metrologico establecido en la reglamentación metrologica.
El certificado no debe ser parcialmente reproducido.

Laboratório de Metrologia da Willy Instrumentos de Medição e Controle Ltda.
Uma empresa ASHCROFT® Inc.

Rua João Pessoa, 620 - Centro - São Caetano do Sul - SP - Brasil - Tel.: (55 11) 4224-7400 - Fax: (55 11) 4224-7477 - E-mail: vendas@ashcroft.com - Site: www.ashcroft.com.br



CERTIFICADO DE QUALIDADE/MILL TEST / QUALITY CERTIFICATE

BR-ML-OURO BRANCO-CHAPA GROSSA
 ROD MG 443 KM 7
 FAZENDA DO CADETE
 OURO BRANCO MG
 36420-000
 BRASIL

CLIENTE/CUSTOMER LAPEFER COMERCIO E INDUSTRIA DE LAM S LTDA	PEDIDO CLIENTE/CUSTOMER ORDER 4536/00000 / 4536 29170	ORDEM VENDA/SALES ORDER 9248349-20	PÁG/PAGE 1 / 1
PRODUTO/PRODUCT Chapa Grossa / Plate	DIMENSÕES/DIMENSIONS 12,50mm x 2500mm x 12000mm		NÚM. CQ/QC. NUM 8126067516-10
NORMA TÉCNICA DO AÇO/SPECIFICATION ASTM A516 GR70 2017	TIPO DE BORDA/EDGE TYPE Aparada / Cut edge	DATA/DATE 09.11.2020	
CONDICÃO DE FORNECIMENTO/DELIVERY CONDITION Como Laminado / As rolled		NF/INVOICE 001719520	

ID VOLUME/VOLUME ID	CHAPA MÃE / MOTHER PLATE	PESO/WEIGHT (KG)	CORRIDA/HEAT	AMOSTRA/SAMPLE
3025259602	NÃO/NO	3.005	27117134	27117134003
3025259603	NÃO/NO	3.005	27117134	27117134003
3025260002	NÃO/NO	3.015	27117134	27117134001
3025260004	NÃO/NO	3.020	27117134	27117134001

COMPOSIÇÃO QUÍMICA/CHEMICAL COMPOSITION												
CORRIDA/HEAT	C (%)	Mn (%)	Si (%)	P (%)	S (%)	Al T (%)	Cr (%)	Cu (%)	Ti (%)	Mo (%)	Nb (%)	Ni (%)
27117134	0,22	1,04	0,18	0,018	0,007	0,033	0,02	0,01	0,002	0,00	0,000	0,01
	V (%)	B (%)	Ca (%)									
27117134	0,004	0,0000	0,0000									

TRAÇÃO / TENSILE TEST						
AMOSTRA/SAMPLE	DIREÇÃO/DIRECTION	POSIÇÃO/POSITION	LE/YP (MPa)	LR/TS (MPa)	LE/LR	ALONG/ELONG (%)
27117134001	Transversal	Borda / Corner	343	531	0,65	37,0
27117134003	Transversal	Borda / Corner	358	545	0,65	38,0

CHAPA FABRICANTE **GERDAU**
 ESPECIE **A-516**
 ESPES. **12,5**
 Nº DE VOLUME **3025260004**
 PRESSÃO DE TESTE **27117134**

BASE DE MEDIDA / GAUGE LENGTH : L0: 50 mm

INSPECTION CONTROLS

Fornecedor: **FELCO S.A.**
 Nº: **291659**
 Nº: **CH023-21**
 SA **516**

14/04/2021
 112211925

2019

Inspeção recebimento

OBSERVAÇÕES/REMARKS

Todas as fontes de radiação são monitoradas e controladas. Toda sucata utilizada no processo de fabricação do aço na usina de Ouro Branco é gerada internamente. Certificamos que este material é isento de contaminação por radiação.
 All radiation sources are verified and controlled.
 All scrap used at Gerdau Ouro Branco is internally generated.
 We certify that this material is free of contamination by radiation.

A Gerdau S.A. certifica que o material aqui descrito está de acordo com as especificações técnicas aplicáveis. Como proteção mútua para cliente e fornecedor, este certificado é considerado como confidencial e não pode ser transcrito ou reproduzido sem a autorização por escrito da Gerdau S.A.

Gerdau S.A. certifies that the material herein described is in accordance with the applicable technical specifications. As mutual protection for costumer and supplier, this certificate is considered as confidential and can not be transcribed or reproduced without the written authorization of Gerdau S.A.

GERENTE DE QUALIDADE/QUALITY MANAGER
TRAYENE OLIVEIRA SILOTTI
 CREA 249773

VISITADOR/SURVEYOR



CERTIFICADO DE QUALIDADE/MILL TEST / QUALITY CERTIFICATE

BR-ML-OURO BRANCO-CHAPA GROSSA
ROD MG 443 KM 7
FAZENDA DO CADETE
OURO BRANCO MG
36420-000
BRASIL

CLIENTE/CUSTOMER LAPEFER COMERCIO E INDUSTRIA DE LAM INADOS LTDA	PEDIDO CLIENTE/CUSTOMER ORDER 4802/00000 / 480230978	ORDEM VENDA/SALES ORDER 10380714-20	PÁG/PAGE 1 / 1
PRODUTO/PRODUCT Chapa Grossa / Plate	DIMENSÕES/DIMENSIONS 12,50mm x 2500mm x 12000mm		NÚM. CQ/QC. NUM 8131850466-10
NORMA TÉCNICA DO AÇO/SPECIFICATION ASTM A516 GR70 2017	TIPO DE BORDA/EDGE TYPE Aparada / Cut edge	DATA/DATE 03.06.2021	
CONDIÇÃO DE FORNECIMENTO/DELIVERY CONDITION Como Laminado / As rolled		NF/INVOICE 001913618	

ID VOLUME/VOLUME ID 3130196301	CHAPA MÃE / MOTHER PLATE SIM/YES	PESO/WEIGHT (KG) 2.995	CORRIDA/HEAT 27120635	AMOSTRA/SAMPLE 27120635004
-----------------------------------	-------------------------------------	-----------------------------	--------------------------	-------------------------------

COMPOSIÇÃO QUÍMICA/CHEMICAL COMPOSITION												
CORRIDA/HEAT	C (%)	Mn (%)	Si (%)	P (%)	S (%)	Al T (%)	Cr (%)	Cu (%)	Ti (%)	Mo (%)	Nb (%)	Ni (%)
27120635	0,24	1,04	0,16	0,014	0,008	0,033	0,02	0,00	0,002	0,00	0,000	0,01
	V (%)	B (%)	Ca (%)									
27120635	0,003	0,0001	0,0000									

TRAÇÃO / TENSILE TEST				CONTROLS		
AMOSTRA/SAMPLE	DIREÇÃO/DIRECTION	POSIÇÃO/POSITION	LE/YP (MPa)	LR/TS (MPa)	LE/LR	ALONG/ELONG (%)
27120635004	Transversal	Borda / Corner	359	C551 PA	0,65	36,0

BASE DE MEDIDA/GAUGE LENGTH : L0: 50 mm

OBSERVAÇÕES/REMARKS

Todas as fontes de radiação são monitoradas e controladas. Toda sucata utilizada no processo de fabricação do aço na usina de Ouro Branco é gerada internamente. Certificamos que este material é isento de contaminação por radiação.
All radiation sources are verified and controlled.
All scrap used at Gerdau Ouro Branco is internally generated.
We certify that this material is free of contamination by radiation.

FABRICANTE: **GERDAU**

ESPECIF.: **A-516**

ESPESS.: **12,5**

DIAM.: _____

COMPRIM.: _____

Nº DE VOLUME: **3130196301**

PRESSÃO DE TESTE: _____

70

27120635

A Gerdau S.A. certifica que o material aqui descrito está de acordo com as especificações técnicas aplicáveis. Como proteção mútua para cliente e fornecedor, este certificado é considerado como confidencial e não pode ser transcrito ou reproduzido sem a autorização por escrito da Gerdau S.A.

Gerdau S.A. certifies that the material herein described is in accordance with the applicable technical specifications. As mutual protection for customer and supplier, this certificate is considered as confidential and can not be transcribed or reproduced without the written authorization of Gerdau S.A.

GERENTE DE QUALIDADE/QUALITY MANAGER

Thayene Oliveira Silotti

THAYENE OLIVEIRA SILOTTI
CREA 249773

JOHNSON CONTROL

VISITADOR/SURVEYOR

Fornecedor: **LAPEFER**

Nº: **264341**

DATA: **03/07/2021**

NR: **CH045-21**

ITEM: **1221925**

Em: _____

Por: **2021**

SA **516**

Inspetor Recebimento

CLIENTE / CUSTOMER / CLIENTE:

PEDIDO CLIENTE / CUSTOMER ORDER / REF. CLIENTE:

JOHNSON CONTROLS BE DO BRASIL LTDA

382359

ITEM	QTDE. QUANTY CANT	DESCRIÇÃO / DESCRIPTION / DESCRIPCION	ESPECIFICAÇÃO SPECIFICATION ESPECIFICACION	CORRIDA HEAT COLADA	NORMA DIMENSIONAL DIMENSIONAL STANDARD NORMA DIMENSIONAL
1	1	FLANGE SLIP-ON 300 RFC DN 8 A105 IT. 1	A-105/18	11907953	ASME B 16.5/17

ITEM	COMPOSIÇÃO QUÍMICA / CHEMICAL COMPOSITION / COMPOSICION QUIMICA											Ti%	CE%
	C%	Mn%	P%	S%	Si%	Cr%	Ni%	Mo%	Cu%	V%	Nb%		
1	0,18	1,02	0,017	0,005	0,24	0,028	0,013	0,004	0,018	0,001			

ITEM	PROPRIEDADES MECÂNICAS / MECHANICAL PROPERTIES / PROPIEDADES MECÂNICAS								MATERIAL DE PARTIDA RAW MATERIAL MATERIA PRIMA	RASTREAB. HCI HCI HEAT TRAZABILIDAD HCI
	FORMA SHAPE FORMA	DIREÇÃO DIRECTION DIRECCION	LIMITE DE ESCOAM. YIELD POINT LIMITE DE FLUENCIA (MPa)	LIMITE DE RESISTÊNCIA TENSILE STRENGTH CARGA DE ROTURA (MPa)	ALONGAMENTO ELONGATION ALARGAMIENTO (%)	ESTRICÇÃO REDUCTION OF AREA ESTRICCION (%)	TR TÉRMICO HEAT TREATMENT TR. TERMICO	DUREZA HARDNESS DUREZA (BRINELL)		
			311	JOHNSON CONTROLS	36,00	67,50	NO	143e148		H21-9196

ITEM: 1344121725
FABRICANTE: DINGXIANG
ESPECIF: A-105
DIAM. 8"

ITEM	TESTE DE IMPACTO / IMPACT TEST / ENSAYO DE IMPACTO				
	A	B	C	MÉDIA AVERAGE PROMEDIO (JOULE)	°C
1	11907953			300 #	3

Observações: >Item: 1-*** ORIG: H20-5251<
REMARKS
OBSERVACIONES

Em conformidade com a ASME
SA 105 Ed. 2021 Ad: —
Inspeção Recebimento

NOTA: Conexões S/A-234 WPBW Sem Tratamento Térmico, foram conformadas a quente entre 620° C e 980° C. Os produtos declarados estão aprovados.
NOTE: Filings S/A-234 WPBW Without Heat Treatment, were hot formed 620°C to 980°C. The products indicated were approved.
Conexiones S/A-234 WPBW Sin Tratamiento Termico, se fabricaron en el rango 620°C a 980°C. Los productos indicados son aprobados.

ST - SEM TRATAMENTO TÉRMICO WITHOUT HEAT TREATMENT SIN TRATAMIENTO TERMICO	RE - RECOZIDO ANNEALED RECOCIDO	NT - NORMALIZADO TEMPERADO E REVENIDO NORMALIZED QUENCHED AND TEMPERED NORMALIZADO TEMPLADO Y REVENIDO	AT - ALÍVIO DE TENSÃO STRESS RELIEVED ALIVIO DE TENSION	RI - RECOZIMENTO ISOTÉRMICO ISOTHERMICAL ANNEALING RECOCIDO ISOTERMICO	Q - QUADRADO STRIP TEST CUADRADO	L - LONGITUDINAL LONGITUDINAL LONGITUDINAL
NO - NORMALIZADO NORMALIZED NORMALIZADO	TR - TEMPERADO E REVENIDO QUENCHED AND TEMPERED TEMPLADO Y REVENIDO	SO - SOLUBILIZADO ANNEALED HIPER TEMPLADO	RV - REVENIDO TEMPERED REVENIDO	NR - NORMALIZADO E REVENIDO NORMALIZED AND TEMPERED NORMALIZADO Y REVENIDO	C - CILÍNDRICO CYLINDRICAL CILÍNDRICO	T - TRANSVERSAL TRANSVERSE TRANSVERSAL
ES - ESTABILIZADO ESTABILIZED ESTABILIZADO	SE - SOLUBILIZADO E ESTABILIZADO ANNEALED AND STABILIZED SOLUBILIZADO Y ESTABILIZADO	ACABAMENTO DA FACE FLANGE FINISH CONTACT FLANGE ACABADO SUPERFICIE DE CONTACTO BRIDA	E - ESPIRAL = 125 - 250 Ra SPIRAL = 125 - 250 Ra ESPIRAL = 125 - 250 Ra	C - CONCÊNTRICO = 125 - 250 Ra CONCENTRIC = 125 - 250 Ra CONCÊNTRICO = 115 - 250 Ra	L - LISO = 125 Ra max SMOOTH = 125 Ra max LISO = 125 Ra max	RJR = 63 Ra max RTJ = 63 Ra max RJ = 63 Ra max

Verificado
Aprovado
Gloves Brandão
Controle da Qualidade

SP - 13/07/2021

DATA / DATE / FECHA

APROVADO ELETRONICAMENTE / ELETRONIC APPROVED / APROBADO POR VIA ELECTRONICA

Rua Santana de Ipanema, 948 - Cidade Industrial Satélite São Paulo - Cep 07220-010 - Guarulhos - SP - Brazil - PABX: (55 11) 2413-8080
Fax Qualidade: 2413-8093 - Fax Vendas: 2413-8088 - E-mail: vendas@hci.ind.br - www.portalhci.com.br

DINGXIANG BEICHENG FLANGE CO.,LTD
Yangfang Development Area Dingxiang Shanxi P.R. China

Inspection Certificate

Abnahmepruefzeugnis

EN10204-3.1

Certified in accordance to Pressure Equipment Directive 2014/68/EU,
 Annex 1, Paragraph 4.3 by TÜV NORD Group
 (Notified Body Identification NO.0045)

Zertifiziert nach Druckgeraete-Richtlinie 2014/68/EU,
 Anhang 1, Abschnitt 4.3 durch TÜV NORD Gruppe
 (Benannte Stelle Kenn-Nr.0045)

Certificate No.: BC-19-Y213 Page: 8/15
 Pruef-Nr. Seite

Customer/Besteller:		Material/Werkstoff		according to/entsprechend	
Order No./Bestell Nr.:	DXBC-2019-Y213 (PO000.074)	Works No./Werks Nr.:	A105	Material/Werkstoff	ASTM A105
dated/vom	2019-11-22	2019-Y213		Specification/Anforderung:	ASME B16.5
Article/Gegenstand:	Hot Forged Flange/geschmiedeter Flansch			Heat Treatment/Erschmelzungsart:	Normalized At 920 °C, air cooling
State of delivery/Lieferzustand:	HOT FORGED				
Marking/Kennzeichnung:	BC HCl Size Standard Class Material Heat-No.				
Stamp of Manufacturer/Herstellerzeichen:				Inspector's stamp/Pruefstempel:	
Content of the Delivery/Lieferumfang:					
NO.	Pieces/stueckzahl	Description/Bezeichnung	Heat No./Schmelze-Nr	Test No./ProbeNr	
30	200	A105 B16.5 300# SO RF 3"	H20-5247	BC19Y21303	
31	200	A105 B16.5 300# SO RF 4"	H20-5248	BC19Y21303	
32	30	A105 B16.5 300# SO RF 5"	H20-5249	BC19Y21303	
33	50	A105 B16.5 300# SO RF 6"	H20-5250	BC19Y21303	
34	100	A105 B16.5 300# SO RF 8"	H20-5251	BC19Y21303	

Chemical analysis/Chemische Analyse:

NO.	Heat No.	%C	%Si	%Mn	%P	%S	%Cr	%Mo	%Ni	%Ti	%Ta	%Nb	%Cu	%Al	%V	%N	%Co
	11907953	0.18	0.24	1.02	0.017	0.005	0.028	0.004	0.013				0.018		0.001		

Mechanical tests/Mechanische Pruefungen:

NO.	Test No./ProbeNr	Yield Strength N/mm ²	Tensile Strength N/mm ²	Elongation %	Reduction of Area %	Charpy-impact Test, ISO-V Specimen	
						Kerbschlagversuch, ISO-V-Probe.	Hardness/Haerte HB
	BC19Y21303	523	523	36.0	67.5	J	143/147/148

Visual and dimensional inspection/Besichtigung und Ausmessung:

Place/Ort: DING XIANG

Date/Datum: 2019-12-22

without completion/ohne Beanstandung

without completion/ohne Beanstandung

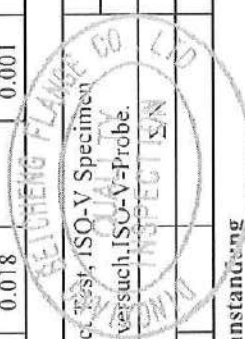

(Handwritten signature)



Vallourec Soluções Tubulares do Brasil S.A.
Distrito Industrial, s/n - Jecoba - MG - CEP: 35498-000 - Brasil

Certificado de Inspeção
(De acordo com DIN EN 10204.3.1)
Nº.: 0050768186 / 00
Folha: 1 / 5

Cliente: IMEFER-INDL E MERCANTIL DE FERRAGENS LTDA.

País: Brasil

Cod.Material: 704994
Pedido Usina: 586116 / 70
Pedido Cliente: P03-202906

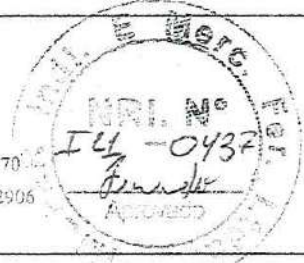

Num.Material Cliente (NCM): 20834

Inspeção: Vallourec Soluções Tubulares do Brasil S.A.

PRODUTO: TUBO DE AÇO SEM COSTURA, LAMINADO À QUENTE, LAMINADO, PONTA CHANFRADA 37,5 GR., (Ângulo do Chanfro-Mínimo: 35,0 grau, Ângulo do Chanfro-Máximo: 40,0 grau), (Face do Chanfro - Mínimo: 0,80 mm, Face do Chanfro - Máximo: 2,40 mm)

DIMENSÕES: 219,10 mm X 8,18 mm GRAU DO AÇO: B # B # B

NORMAS: API SPEC 5L, 04.2018, 46TH EDITION - PSL 1

ATENDE TAMBÉM ÀS NORMAS: ASTM A106M - 19 # A # ASTM A 530M - 18 # ABNT NBR 6321, 04.2011

PROTEÇÃO SUPERFICIAL: EXTERNA: SEM PROTECAO INTERNA: SEM PROTECAO **PROTEÇÃO DE PONTAS:** CAPA DE POLIETILENO COM FURO

TOLERÂNCIAS: DIÂMETRO EXTERNO(CORPO TUBO): -0,80 mm / +1,60 mm **PAREDE:** -1,02 mm / +1,23 mm

TOLERÂNCIAS(PONTAS): DIÂMETRO EXTERNO: -0,80 mm / +1,10 mm

COMPRIMENTO: FAIXA 5000,00 mm - 7000,00 mm

MARCAÇÃO DE NORMA: PAINT STENCILED: MANUFACTURER API Spec 5L 0867 API MONOGRAM MONTH/YEAR ASTM A-106M / ABNT NBR 6321 219.1 8.18 B/B/B PSL1 SMLS HEAT NUMBER LENGTH S TESTED 11.0

MPA/NDE/END WEIGHT PIPE TALLY NO Segurança ABNT LOGO INMETRO 062488/2018 002483/2018 VSB LOGO

1112+2045
TB-059-21

Corrida	Amarrado	Peças	Comprimento(m)	Peso (Kgf)
190166	5001284068	1	6,8	295
	5001284069	1	6,8	292
	5001284070	1	6,8	293
	5001284071	1	6,8	294
	5001284072	1	6,8	294
	5001284079	1	6,8	293
	5001284080	1	6,8	291
	5001284081	1	6,8	287
	5001284085	1	6,8	292
	5001284086	1	6,8	289
	5001284087	1	6,8	293
	5001284088	1	6,8	293
	5001284089	1	6,8	293
	5001284094	1	6,8	295
	5001284101	1	6,8	291
	5001284102	1	6,8	294
	5001284103	1	6,8	294

JOHNSON CONTROLS

Fornecedor: **IMEFER**

NR: **Lo3.008** 16/06/2021

NR: **TB059-21** 1112+2045

SA **Lob** 2019

Inspeção Rec: **f**

O CERTIFICADO ORIGINAL DO FORNECEDOR FABRICANTE ENCONTRA-SE EM MOSSOZ ATENTE CONSULTA

18 JUN 2021

CHAPA

FABRICANTE **Vallourec**

ESPECIE **A-206** **B**

ROSPES **8,18**

DIAM. **219,10** **40**

COMPRI **23,56** **190206**

Nº DE VOLUMES

PRESSÃO DE TESTE

Corrida	Amarrado	Peças	Comprimento(m)	Peso (Kgf)
	5001284104	1	6,8	293
	5001284120	1	6,8	294
	5001284121	1	6,8	293
	5001284122	1	6,8	296
	5001284123	1	6,9	297
	5001284124	1	6,9	295
	5001284128	1	6,9	302
	5001284129	1	6,7	292
	5001284130	1	6,7	289
	5001284142	1	6,69	295
	5001284143	1	6,85	294
	5001284146	1	6,85	296
	5001284148	1	6,85	296
	5001284157	1	6,9	296
	5001284164	1	6,9	295
	5001284165	1	6,9	294
	5001284167	1	6,85	295
	5001284168	1	6,85	296
	5001284169	1	6,84	292
	5001284170	1	6,7	288
	5001284171	1	6,7	287
	5001284173	1	6,9	296
	5001284177	1	6,9	299
	5001284178	1	6,9	298
	5001284185	1	6,8	294
	5001284186	1	6,8	296
	5001284187	1	6,8	295
	5001284188	1	6,75	291
	5001284189	1	6,75	294
	5001284190	1	6,74	290
	5001284191	1	6,9	297
	5001284202	1	6,9	294



O CERTIFICADO ORIGINAL DO FORNECEDOR
 POR FABRICANTE ENCONTRA-SE EM
 Nossos Arquivos para CONSULTA
 08 JUN 2021
 WEFER Indústria e Comércio de Ferragens Ltda

Certificado de Inspeção

(De acordo com DIN EN 10204.3.1)

Nº.: 0050768186 / 00

Folha: 3 / 5

Corrida	Amarrado	Peças	Comprimento(m)	Peso (Kgf)
	5001284204	1	6,9	296
	5001284227	1	6,84	296
	5001284228	1	6,84	293
	5001284229	1	6,79	292
	5001284236	1	6,79	291
	5001284237	1	6,79	293
	5001284238	1	6,88	295
	5001284239	1	6,88	292
	5001284240	1	6,88	290
	5001284241	1	6,77	291
	5001284248	1	6,88	292
	5001284249	1	6,88	296
	5001284250	1	6,84	294
	5001284252	1	6,84	292
	5001284253	1	6,83	294
	5001284254	1	6,87	296
	5001284258	1	6,7	290
	5001284259	1	6,72	290
	5001284260	1	6,78	292
	5001284263	1	6,76	291
	5001284264	1	6,76	291
	5001284265	1	6,76	293
	5001284266	1	6,95	299
	5001284267	1	6,94	297
	5001284268	1	6,53	285
	5001284269	1	6,71	290
	5001284270	1	6,71	288
	5001284271	1	6,71	295
	5001284275	1	6,9	297
	5001284276	1	6,72	290
	5001284277	1	6,65	287
	5001284290	1	6,87	295



O CERTIFICADO ORIGINAL DO FORNECEDOR FABRICANTE ENCONTRA-SE EM NOSSOS ARQUIVOS PARA CONSULTA

08 JUN 2021

IMAFER Industrial e Mercantil de Ferragens Ltda

Corrida	Amarrado	Peças	Comprimento(m)	Peso (Kgf)
	5001284291	1	6,78	290
	5001284292	1	6,97	298
	5001284299	1	6,86	295
	5001284300	1	6,86	294
	5001284301	1	6,85	292
	5001284303	1	6,98	300
	5001284304	1	6,99	300
	5001284305	1	6,73	292
	5001284306	1	6,98	299
	5001284307	1	6,64	287
	5001284308	1	6,64	287
	5001284340	1	6,75	290
	5001284341	1	6,75	292
	5001284342	1	6,75	293
	5001284353	1	6,78	292
	5001284354	1	6,78	295
	5001284355	1	6,78	292
	5001284357	1	6,63	285
	5001284359	1	6,63	286
	Total	100	680,72	29314



O PRODUTO FOI APROVADO NOS SEGUINTE TESTES/INSPECÇÕES: DIMENSIONAL # VISUAL # TESTE HIDROSTÁTICO: 11,0 MPA 5 S # MAGNETISMO RESIDUAL MÁXIMO : 30 GAUSS # TESTE ELETROMAGNÉTICO : L4(N12.5), LONG/TRANS, EXT #.

O CERTIFICADO ORIGINAL DO FORNECEDOR FABRICANTE ENCONTRA-SE EM NOSSOS ARQUIVOS PARA CONSULTA

IMEFER Industrial e Mercantil de Ferragens Ltda

Composição Química (%)

Forno Elétrico a Arco, aço acalmado

 Ceq: $C + Mn/6 + (Cr + Mo + V)/5 + (Ni + Cu)/15$

DI:

EC1: Nb + V

EC2: Nb + V + Ti

EC3: Cr + Cu + Mo + Ni + V

		C	Mn	P	S	Si	Ni	Cr	Mo	Al	Cu	V	Nb	B	Ti	Ca	Ceq	EC1	EC2	EC3	
Análise de Corrida	Min		0,29			0,10															
	Max	0,250	1,35	0,030	0,0300		0,40	0,40	0,150		0,40	0,080		0,0010			0,43	0,06	0,15	1,00	
Análise de Produto	Min		0,29			0,10															
	Max	0,250	1,35	0,030	0,0300		0,40	0,40	0,150		0,40	0,080		0,0010			0,43	0,06	0,15	1,00	
Corrida	IPPN																				
190166	Ladle	0,190	1,02	0,010	0,0010	0,20	0,06	0,10	0,033	0,027	0,08	0,020	0,000	0,0000	0,002	0,0010	0,40	0,02	0,02	0,29	
Check 1	503020	0,187	1,02	0,010	0,0013	0,20	0,06	0,10	0,030	0,028	0,07	0,022	0,000	0,0000	0,002	0,0013	0,40	0,02	0,02	0,28	
Check 2	203010	0,187	1,02	0,010	0,0009	0,20	0,06	0,10	0,030	0,029	0,07	0,022	0,001	0,0000	0,002	0,0012	0,40	0,02	0,02	0,28	



Ceq: Carbono Equivalente; EC: Elementos Combinados:

Ensaio de Tração

Direção do Corpo Prova: Longitudinal

Temperatura: Ambiente

Corpo de Prova TIRA LARGURA 38,1 MM

Espessura da parede: 8,18 mm

Medida L0: L0=50MM

Método LE: Along. Total Sob Carga 0,50 %

		LE	RT	AL
		(MPa)	(MPa)	(%)
	Especificado: Min	245	415	27
	Max			
Corrida	IPPN			
190166	201040	357	542	40
	203010	354	539	40

O CERTIFICADO ORIGINAL DO FORNECEDOR FABRICANTE ENCONTRA-SE EM NOSSOS ARQUIVOS PARA CONSULTA

2021

INEFER Industrial e Mercantil de Ferragens Ltda

LE-Limite de Escoamento; RT-Resistência a Tração; AL-Alongamento;

Observações:

NOTA FISCAL: 000357019

Certificamos que este material foi produzido e inspecionado de acordo com todas as exigências destas normas e especificações, e todos os resultados considerados satisfatórios. Este Certificado é processado por sistema informatizado e é válido sem assinatura.

DEPARTAMENTO DE CONTROLE DE QUALIDADE

FAX: (55-31) 2141 5365

e-mail: carlos.horta@vstubs.com

DATA

27.03.2021

Carlos Eduardo Lima Horta

CARLOS EDUARDO LIMA HORTA

RESPONSÁVEL TÉCNICO



HCI - Hidráulica, Conexões Industriais Ltda.
A NOSSA MELHOR CONEXÃO COM VOCÊ.
CERTIFICADO DE QUALIDADE Nº 40526701



Conexão sem limites

MILL TEST CERTIFICATE / CERTIFICADO DE CALIDAD
EN 10204-3.1

CLIENTE / CUSTOMER / CLIENTE:

JOHNSON CONTROLS BE DO BRASIL LTDA

PEDIDO CLIENTE / CUSTOMER ORDER / REF. CLIENTE:

383259

ITEM	QTDE. QUANTY CANT	DESCRIÇÃO / DESCRIPTION / DESCRIPCION	ESPECIFICAÇÃO SPECIFICATION ESPECIFICACION	CORRIDA HEAT COLADA	NORMA DIMENSIONAL DIMENSIONAL STANDARD NORMA DIMENSIONAL
1	2	LUVA TIPO COUPOLET 3M 2 A105 CONF, DESENHO IT.1	A-105/18	BTM	CONF DESENHO

ITEM	COMPOSIÇÃO QUÍMICA / CHEMICAL COMPOSITION / COMPOSICION QUIMICA												Ti%	CE%
	C%	Mn%	P%	S%	Si%	Cr%	Ni%	Mo%	Cu%	V%	Nb%	N%		
1	0,22	1,31	0,009	0,008	0,2	0,11	0,17	0,01	0,06	0,01				

ITEM	PROPRIEDADES MECÂNICAS / MECHANICAL PROPERTIES / PROPIEDADES MECÂNICAS								MATERIAL DE PARTIDA RAW MATERIAL MATERIA PRIMA	RASTREAB. HCI HCI HEAT TRAZABILIDAD HCI
	FORMA SHAPE FORMA	DIREÇÃO DIRECTION DIRECCION	LIMITE DE ESCOAM. YIELD POINT LIMITE DE FLUENCIA (MPa)	LIMITE DE RESISTÊNCIA TENSILE STRENGTH CARGA DE ROTURA (MPa)	ALONGAMENTO ELONGATION ALARGAMIENTO (%)	ESTRICÇÃO REDUCTION OF AREA ESTRICCION (%)	TR TÉRMICO HEAT TREATMENT TR. TÉRMICO	DUREZA HARDNESS DUREZA (BRINELL)		
1	C		401	604	28,00	67,00	ST	167e170	H21-1906	
<p>ITEM: 944A0130H09S FABRICANTE: Qualifec ESPECIE: A-205 DIAM.: 2"</p>										

TESTE DE IMPACTO / IMPACT TEST / ENSAYO DE IMPACTO												
ITEM	CORRIDA RATING			MÉDIA AVERAGE PROMEDIO (JOULE)	°C	ITEM	CORRIDA RATING			MÉDIA AVERAGE PROMEDIO (JOULE)	°C	
	A	B	C				A	B	C			
1	BTM			3000H								

Observações:
 REMARKS
 OBSERVACIONES

SA LOS 2022 Ad: _____
 Inspetor Recebimento

NOTA: Conexões S/A-234 WPB/W Sem Tratamento Térmico, foram conformadas a quente entre 620° C e 980° C. Os produtos declarados estão aprovados.
 NOTE: Fittings S/A-234 WPB/W Without Heat Treatment, were hot formed 620°C to 980°C. The products indicated were approved.
 Conexiones S/A-234 WPB/W Sin Tratamiento Termico, se fabricaron en el rango 620°C a 980°C. Los productos indicados son aprobados.

ST - SEM TRATAMENTO TÉRMICO WITHOUT HEAT TREATMENT SIN TRATAMIENTO TÉRMICO	RE - RECOZIDO ANNEALED RECOCIDO	NT - NORMALIZADO TEMPERADO E REVENIDO NORMALIZED QUENCHED AND TEMPERED NORMALIZADO TEMPLADO Y REVENIDO	AT - ALÍVIO DE TENSÃO STRESS RELIEVED ALIVIO DE TENSION	RI - RECOZIMENTO ISOTÉRMICO ISOTHERMAL ANNEALING RECOCIDO ISOTERMICO	Q - QUADRADO STRIP TEST CUADRADO	L - LONGITUDINAL LONGITUDINAL LONGITUDINAL
NO - NORMALIZADO NORMALIZED NORMALIZADO	TR - TEMPERADO E REVENIDO QUENCHED AND TEMPERED TEMPLADO Y REVENIDO	SO - SOLUBILIZADO ANNEALED HIPER TEMPLADO	RV - REVENIDO TEMPERED REVENIDO	NR - NORMALIZADO E REVENIDO NORMALIZED AND TEMPERED NORMALIZADO Y REVENIDO	C - CILÍNDRICO CYLINDRICAL CILINDRICO	T - TRANSVERSAL TRANSVERSE TRANSVERSAL
ES - ESTABILIZADO ESTABILIZED ESTABILIZADO	SE - SOLUBILIZADO E ESTABILIZADO ANNEALED AND STABILIZED SOLUBILIZADO Y ESTABILIZADO	ACABAMENTO DA FACE FLANGE FINISH CONTACT FLANGE ACABADO SUPERFICIE DE CONTACTO BRIDA	E - ESPIRAL = 125 - 250 Ra SPIRAL = 125 - 250 Ra ESPIRAL = 125 - 250 Ra	C - CONCÊNTRICO = 125 - 250 Ra CONCENTRIC = 125 - 250 Ra CONCÊNTRICO = 125 - 250 Ra	L - LISO = 125 Ra max SMOOTH = 125 Ra max LISO = 125 Ra max	RJR = 63 Ra max RTJ = 63 Ra max RJ = 63 Ra max

SP - 03/08/2021

DATA / DATE / FECHA

APROVADO ELETRONICAMENTE / ELETRONIC APPROVED / APROBADO POR VIA ELECTRONICA

Rua Santana de Ipanema, 948 - Cidade Industrial Satélite São Paulo - Cep 07220-010 - Guarulhos - SP - Brazil - PABX: (55 11) 2413-8080
 Fax Qualidade: 2413-8093 - Fax Vendas: 2413-8088 - E-mail: vendas@hci.ind.br - www.portalhci.com.br

CERTIFICADO DE QUALIDADE / QUALITY CERTIFICATE

No. 1027_B

QUALITEC CONEXÕES INDUSTRIAIS LTDA
 Tel. (11) 2749-7011 - 2749-6764
 Rua do Cádmo, 40 - Cep: 08280-110 - Cidade Líder - São Paulo - SP
 CNPJ: 25.099.824/0001-51 I.E.: 140.988.903.118

Item/ Customer	45	HCI HIDRAULICA, CONEXOES IND. LTDA	Ped. Cliente/ Customer Order	141.602	Nota Fiscal/ Invoice	1650	Emissão/ Emission	17/02/2021
Item/ Customer		Descrição do Material/ Material Description	Norma de Material/ Material Norm	Norma de Produção/ Production Standard	Material de Partida/ Starting Material			
1		LUVA TIPO COUPOLET A LOS 3000L NPT DN 2" - CONF. DESENHO H21-1900	A/S ALOS #N/D	CONF. DESENHO	BARRA RED. SAE 1522 - 75-20 #N/D			
2		4840044 #N/D	#N/D		#N/D			

Composição Química (%) / Chemical Composition (%)

Item	Corrida Running	Quant. Quant.	C	Mn	P	S	Si	Ni	Cr	Mo	Cu	V	Nb	Al	Ti	N	Zn	Fe	Sn	Pb	Ca	Ta	W	U	CO
1	BTM	10	0,220	1,310	0,009	0,008	0,200	0,170	0,110	0,010	0,060	0,010	0,000	0,013	0,000	0,006	0,000	0,000	0,000	0,000	0,000	0,000	0,010	0,000	0,000
2			#N/D	#N/D	#N/D	#N/D	#N/D	#N/D	#N/D	#N/D	#N/D	#N/D	#N/D	#N/D	#N/D	#N/D	#N/D	#N/D	#N/D	#N/D	#N/D	#N/D	#N/D	#N/D	#N/D

Teste de Tração / Traction Test

Item/ Item	Norma/ Standard	Corpo Prova/ Specimen	Direção Corpo/ Body Direction	Posição Corpo/ Specimen Position	Temperatura/ Temperature	Limite Escoamento/ Flow Limit (MPa)	Limite Resistência/ Resistance Limit (MPa)	Alongamento/ Stretching (%)	Estrição/ Striction (%)	Módulo* Method*	Resultado do Teste/ Test Result	Tratamento Térmico/ Heat Treatment
1					401	401	604	25,00	67	S	167 / 170	SEM TRATAMENTO
2					#N/D	#N/D	#N/D	#N/D	#N/D	#N/D	#N/D	#N/D
0					#N/D	#N/D	#N/D	#N/D	#N/D	#N/D	#N/D	#N/D
0					#N/D	#N/D	#N/D	#N/D	#N/D	#N/D	#N/D	#N/D

Teste de Impacto / Impact Test

Item/ Item	Norma/ Standard	Corpo Prova/ Specimen	Direção Corpo/ Specimen Direction	Posição Corpo/ Specimen Position	Temperatura/ Temperature	Corpo Prova A/ Specimen A	Corpo Prova B/ Specimen B	Corpo Prova C/ Specimen C	Média/ Average
0									
0									
0									
0									

Observações / Comments:

OS CERTIFICADOS ORIGINAIS ENCONTRAM-SE EM NOSSO PODEOL. A SUA DISPONIBILIDADE, CERTIFICADOS DE QUALIDADE (CQ) PRODUTOS SUPS (S) APROVADOS DE ACORDO COM AS ESPECIFICAÇÕES ACIMA MENCIONADAS. / THE ORIGINAL CERTIFICATES ARE FOUND AT OUR POWER. AT YOUR DISPOSAL. WE CERTIFY THAT THIS SUITABLE PRODUCT (S) ARE APPROVED, IN ACCORDANCE WITH THE ABOVE SPECIFICATIONS.

São Paulo 17/02/2021

André G. Vieira - Depto Qualidade/ Quality Department

18-02-21
Paulo



HCI - Hidráulica, Conexões Industriais Ltda.
 A NOSSA MELHOR CONEXÃO COM VOCÊ.
CERTIFICADO DE QUALIDADE Nº 40527406
 MILL TEST CERTIFICATE / CERTIFICADO DE CALIDAD
 EN 10204-3.1



CLIENTE / CUSTOMER / CLIENTE: **JOHNSON CONTROLS BE DO BRASIL LTDA** PEDIDO CLIENTE / CUSTOMER ORDER / REF. CLIENTE: **383260**

ITEM	QTDE. QUANTY CANT	DESCRIÇÃO / DESCRIPTION / DESCRIPCION	ESPECIFICAÇÃO SPECIFICATION ESPECIFICACION	CORRIDA HEAT COLADA	NORMA DIMENSIONAL DIMENSIONAL STANDARD NORMA DIMENSIONAL
6	40	LUVA 3000 NPT 1/2 A105 IT.6	A-105/18	070H	ASME B 16.11/16

ITEM	COMPOSIÇÃO QUÍMICA / CHEMICAL COMPOSITION / COMPOSICION QUIMICA										Ti%	CE%
	C%	Mn%	P%	S%	Si%	Cr%	Ni%	Mo%	Cu%	V%	Nb%	N%
6	0,19	0,82	0,017	0,006	0,25	0,05	0,01	0,0059	0,02	0,0043		

ITEM	PROPRIEDADES MECÂNICAS / MECHANICAL PROPERTIES / PROPIEDADES MECÂNICAS						MATERIAL DE PARTIDA RAW MATERIAL MATERIA PRIMA	RASTREAB. HCI HCI HEAT TRAZABILIDAD HCI
	Corpo de Prova Specimen Probeta	LIMITE DE ESCOAM. YIELD POINT LIMITE DE FLUENCIA (MPa)	LIMITE DE RESISTÊNCIA TENSILE STREIGHT CARGA DE ROTURA (MPa)	ALONGAMENTO ELONGATION ALARGAMIENTO (%)	ESTRICCÃO REDUCTION OF AREA ESTRICCION (%)	TR TÉRMICO HEAT TREATMENT TR. TERMICO		
6	286	532	35,00	52,00	NO	146e167	H20-12330	

ITEM 2342+9985
FABRICA PT JIANGSU
ESPECIE A-105
DIAM. 1 1/2"

TESTE DE IMPACTO / IMPACT TEST / ENSAYO DE IMPACTO											
ITEM	A (JOULE)	B (JOULE)	C (JOULE)	MÉDIA AVERAGE PROMEDIO (JOULE)	°C	ITEM	A (JOULE)	B (JOULE)	C (JOULE)	MÉDIA AVERAGE PROMEDIO (JOULE)	°C
6	3000										

Observações:
REMARKS
OBSERVACIONES

Fornecedor: **HCI**
 Nº: **0127819** DATA: **12/08/2021**
 NR: **070H** ITENS: **1342+9985**
 SA: **105** 2021 Ad: **-**
 Inspector Re: **Equipe**

NOTA: Conexões S/A-234 WPB/W Sem Tratamento Térmico, foram conformadas a quente entre 620° C e 980° C. Os produtos declarados estão aprovados.
 NOTE: Fittings S/A-234 WPB/W Without Heat Treatment, were hot formed 620°C to 980°C. The products indicated were approved.
 Conexiones S/A-234 WPB/W Sin Tratamiento Termico, se fabricaron en el rango 620°C a 980°C. Los productos indicados son aprobados.

ST - SEM TRATAMENTO TÉRMICO WITHOUT HEAT TREATMENT SIN TRATAMIENTO TERMICO	RE - RECOZIDO ANNEALED RECOCIDO	NT - NORMALIZADO TEMPERADO E REVENIDO NORMALIZED QUENCHED AND TEMPERED NORMALIZADO TEMPLADO Y REVENIDO	AT - ALÍVIO DE TENSÃO STRESS RELIEVED ALIVIO DE TENSION	RI - RECOZIMENTO ISOTÉRMICO ISOTHERMAL ANNEALING RECOCIDO ISOTERMICO	Q - QUADRADO STRIP TEST CUADRADO	L - LONGITUDINAL LONGITUDINAL LONGITUDINAL
NO - NORMALIZADO NORMALIZED NORMALIZADO	TR - TEMPERADO E REVENIDO QUENCHED AND TEMPERED TEMPLADO Y REVENIDO	SO - SOLUBILIZADO ANNEALED HIPER TEMPLADO	RV - REVENIDO TEMPERED REVENIDO	NR - NORMALIZADO E REVENIDO NORMALIZED AND TEMPERED NORMALIZADO Y REVENIDO	C - CILINDRICO CYLINDRICAL CILINDRICO	T - TRANSVERSA TRANSVERSE TRANSVERSAL
ES - ESTABILIZADO ESTABILIZED ESTABILIZADO	SE - SOLUBILIZADO E ESTABILIZADO ANNEALED AND STABILIZED SOLUBILIZADO Y ESTABILIZADO	ACABAMENTO DA FACE FLANGE FINISH CONTACT FLANGE ACABADO SUPERFÍCIE DE CONTACTO BRIDA	E - ESPIRAL = 125 - 250 Ra SPIRAL = 125 - 250 Ra ESPRAL = 125 - 250 Ra	C - CONCÊNTRICO = 125 - 250 Ra CONCENTRIC = 125 - 250 Ra CONCÊNTRICO = 125 - 250 Ra	L - LISO = 125 Ra max SMOOTH = 125 Ra max LISO = 125 Ra max	RJR = 63 Ra max RTJ = 63 Ra max RJ = 63 Ra max

SP - 03/08/2021

DATA / DATE / FECHA

APROVADO ELETRONICAMENTE / ELETRONIC APPROVED / APROBADO POR VIA ELECTRONICA

Rua Santana de Ipanema, 948 - Cidade Industrial Satélite São Paulo - Cep 07220-010 - Guarulhos - SP - Brazil - PABX: (55 11) 2413-8080
 Fax Qualidade: 2413-8093 - Fax Vendas: 2413-8088 - E-mail: vendas@hci.ind.br - www.portalhci.com.br



江苏海达管件集团有限公司

JIANGSU HAIDA PIPE FITTINGS GROUP CO., LTD

ADD:GUANHUA (E) RD. JIANHU (JIANHU ECONOMIC DEVELOP ZONE) JIANGSU CHINA

TEL: 86 (0515) 8625 5695 /8625 2999 FAX: (0515) 8625 5661

MILL TEST & INSPECTION CERTIFICATE

acc. To EN 10204 / DIN 10204 / DIN 50049/3.1B ** NACE MR. 0175 Ed. 2000/ISO9001:2015

CUSTOMER: HCL

INVOICE NO.: 200504085

DATE: 2020.5.25

CERT. NO.: MC20052100008

ORDER NO.: PO.000122

PAGE: 2/5

Material Specification: ASTM A105

ITEM	HEAT CODE	CHARGE NO.	DESCRIPTION	QTY	MECHANICAL TEST				Impact (J)	HARDN ESS (HB)
					YS (Mpa)	TS (Mpa)	EL (%)	RA (%)		
					250	485	22	30		
20-05-04103	070H	29R06	NPT COUPLING 1/2" 3000 A105	1500	286	532	35	52	H20-12330	146-167
20-05-04104	074H	29R07	NPT COUPLING 3/4" 3000 A105	1500	288	524	38	52	H20-12331	136-164
20-05-04105	074H	29R07	NPT COUPLING 1" 3000 A105	500	288	524	38	52	H20-12332	136-164
20-05-04106	772B	29R05	NPT COUPLING 1-1/2" 3000 A105	500	282	513	34	56	H20-12333	134-163
20-05-04107	772B	29R05	NPT COUPLING 2" 3000 A105	700	282	513	34	56	H20-12334	134-163
20-05-04108	3047	29R18	NPT COUPLING 2-1/2" 3000 A105	50	282	516	33	53	H20-12335	145-164
20-05-04109	070H	29R06	NPT COUPLING 1/2" 6000 A105	100	286	532	35	52	H20-12336	146-167
20-05-04110	074H	29R07	NPT COUPLING 3/4" 6000 A105	150	288	524	38	52	H20-12337	136-164
20-05-04111	074H	29R07	NPT COUPLING 1" 6000 A105	100	288	524	38	52	H20-12338	136-164
20-05-04112	772B	29R05	NPT COUPLING 2" 6000 A105	50	282	513	34	56	H20-12339	134-163
20-05-04113	074H	29R07	SW HALF CPL 1" 3000 A105	500	288	524	38	52	H20-12340	136-164
20-05-04114	772B	29R05	SW HALF CPL 1-1/2" 3000 A105	300	282	513	34	56	H20-12341	134-163
20-05-04115	070H	29R06	NPT HALF CPL 1/2" 3000 A105	1000	286	532	35	52	H20-12342	146-167
20-05-04116	074H	29R07	NPT HALF CPL 3/4" 3000 A105	500	288	524	38	52	H20-12343	136-164
20-05-04117	772B	29R05	NPT HALF CPL 1-1/2" 3000 A105	150	282	513	34	56	H20-12344	134-163
20-05-04118	772B	29R05	NPT HALF CPL 1-1/2" 6000 A105	50	282	513	34	56	H20-12345	134-163
20-05-04119	070H	29R06	SW TEE 1/2" 3000 A105	1000	286	532	35	52	H20-12346	146-167
20-05-04120	074H	29R07	SW TEE 3/4" 3000 A105	1500	288	524	38	52	H20-12347	136-164

DIMENSION: ASME B16.11
 THREADS: ANSI/ASME B1.20.1
 VISUAL & DIMENSION: GOOD

ITEM	HEAT CODE	C	Si	Mn	P	S	Cr	Ni	Mo	Ti	V	Cu	AL	CE
Min		0.1	0.6											
Max		0.35	0.35	1.05	0.035	0.04	0.3	0.4	0.12	-	0.08	0.4	-	-
20-05-04103	070H	0.19	0.25	0.82	0.017	0.006	0.05	0.01	0.0059		0.0043	0.02		
20-05-04104	074H	0.20	0.24	0.83	0.015	0.007	0.05	0.01	0.0021		0.0037	0.02		
20-05-04105	074H	0.20	0.24	0.83	0.015	0.007	0.05	0.01	0.0021		0.0037	0.02		
20-05-04106	772B	0.23	0.26	0.94	0.009	0.005	0.04	0.01	0.0001		0.0047	0.02		
20-05-04107	772B	0.23	0.26	0.94	0.009	0.005	0.04	0.01	0.0001		0.0047	0.02		
20-05-04108	3047	0.20	0.22	0.91	0.017	0.006	0.02	0.02	0.01		0.003	0.02		
20-05-04109	070H	0.19	0.25	0.82	0.017	0.006	0.05	0.01	0.0059		0.0043	0.02		
20-05-04110	074H	0.20	0.24	0.83	0.015	0.007	0.05	0.01	0.0021		0.0037	0.02		
20-05-04111	074H	0.20	0.24	0.83	0.015	0.007	0.05	0.01	0.0021		0.0037	0.02		
20-05-04112	772B	0.23	0.26	0.94	0.009	0.005	0.04	0.01	0.0001		0.0047	0.02		
20-05-04113	074H	0.20	0.24	0.83	0.015	0.007	0.05	0.01	0.0021		0.0037	0.02		
20-05-04114	772B	0.23	0.26	0.94	0.009	0.005	0.04	0.01	0.0001		0.0047	0.02		
20-05-04115	070H	0.19	0.25	0.82	0.017	0.006	0.05	0.01	0.0059		0.0043	0.02		
20-05-04116	074H	0.20	0.24	0.83	0.015	0.007	0.05	0.01	0.0021		0.0037	0.02		
20-05-04117	772B	0.23	0.26	0.94	0.009	0.005	0.04	0.01	0.0001		0.0047	0.02		
20-05-04118	772B	0.23	0.26	0.94	0.009	0.005	0.04	0.01	0.0001		0.0047	0.02		
20-05-04119	070H	0.19	0.25	0.82	0.017	0.006	0.05	0.01	0.0059		0.0043	0.02		
20-05-04120	074H	0.20	0.24	0.83	0.015	0.007	0.05	0.01	0.0021		0.0037	0.02		

Remark:
 * STEEL MAKING PROCESS: ELECTRIC FURNACE
 * H. T NORMALIZED: 920° C - Air COOLING

WE CERTIFY THE ABOVE MENTIONED FITTINGS HAVE BEEN MANUFACTURED AND TESTED IN ACCORDANCE WITH THE SPECIFICATIONS SHOWN

*Outlet MSS SP-97
 *SML Swag Nipple MSS SP-95
 *Unions MSS SP-83



Q. C. MANAGER

INSPECTOR

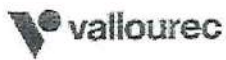

Vallourec Soluções Tubulares do Brasil S.A.
Usina Barreiro - Av. Orlino Meireles, 65
Barreiro de Baixo - CEP: 30640-010



Certificado de Inspeção

(De acordo com DIN EN 10204.3.1)

Nº.: 0050739775 / 00

Folha: 1 / 3

Cliente: IMEFER-INDL E MERCANTIL DE FERRAGENS LTDA.

País: Brasil

Cod.Material: 277636

Pedido Usina: 571236 / 70

Num.Material Cliente (NCM): 20702

Pedido Cliente: P08-202759

Inspeção: VALLOUREC SOL.TUBULARES BRASIL S.A BARREIRO

DESCRIÇÃO DO PRODUTO: TUBO DE AÇO SEM COSTURA, LAMINADO À QUENTE, PONTA CHANFRADA 37,5 GR., LAMINADO
DIMENSÕES: 73,00 mm X 5,16 mm GRAU DO AÇO: X42 # B # B
NORMAS: API SPEC 5L, 04.2018, 46TH EDITION - PSL 1
ATENDE TAMBÉM ÀS NORMAS: ASTM A 106M - 19 A ASTM A 530M - 18 # ASTM A 53M - 18
PROTEÇÃO SUPERFICIAL: EXTERNA: LAQUE INCOLOR PROTEÇÃO DE PONTAS: CAPA PLÁSTICA
TOLERÂNCIAS: DIÂMETRO EXTERNO(CORPO TUBO): -0,55 mm / +0,55 mm PAREDE: -0,66 mm / +0,77 mm
TOLERÂNCIAS(PONTAS): DIÂMETRO EXTERNO: -0,40 mm / +0,73 mm
COMPRIMENTO: FIXO 6000,00 mm TOLERÂNCIAS: -0,00 mm \ +100,00 mm

1112+1995
* TB-060-21



Corrida	Amarrado	Peças	Comprimento(m)	Peso (Kgf)
184956	PCA6160216	51	309,70	2690
	PCA6160219	48	291,35	2530
★ 185654	PCA6165490	44	266,54	2328
	PCA6165491	40	242,36	2118
Total		183	1109,95	9666

O PRODUTO FOI APROVADO NOS SEGUINTES TESTES/INSPEÇÕES: DIMENSIONAL # VISUAL # TESTE DE ACHATAMENTO # TESTE HIDROSTÁTICO: 20500,0 KPA 5 S #

JOHNSON CONTROLS

Fornecedor: IMEFER

203004

TB060-21

206

2019

26/06/2021

1112+1995

Inspeção

JOHNSON CONTROLS

CHAPA

FABRICANTE: Vallourec

ESPECIE: A-106

ESPESS: 5,16

DIAM: 73,00

COMPR: 13

40

185654

20500 KPA

O CERTIFICADO ORIGINAL DO FORNECEDOR FABRICANTE ENCONTRA-SE EM NOSSOS ARQUIVOS PARA CONSULTA

08 JUN 2021

IMEFER Industrial e Mercantil de Ferragens Ltda



Certificado de Inspeção

(De acordo com DIN EN 10204.3.1)

Nº.: 0050739775 / 00

Folha: 2 / 3

Composição Química (%)

Processo: Forno básico a oxigênio, aço acalmado

EC1: Nb + V

EC2: Nb + V + Ti

EC3: Cr + Cu + Mo + Ni + V

		C	Mn	P	S	Si	Ni	Cr	Mo	Al	Cu	V	Nb	B	Ti	Ca	EC1	EC2	EC3	
Análise de Corrida	Min		0,290			0,100														
	Max	0,220	1,150	0,025	0,025		0,400	0,400	0,150		0,400	0,080		0,0010	0,040		0,060	0,150	1,000	
Análise de Produto	Min		0,290			0,100														
	Max	0,220	1,150	0,025	0,025		0,400	0,400	0,150		0,400	0,080		0,0010	0,040		0,060	0,150	1,000	
Corrida Lote Controle																				
	184956 030003360875	0,17	1,09	0,012	0,002	0,31	0,04	0,07	0,01	0,028	0,080	0,003	0,001	0,0000	0,002	0,0016	0,004	0,006	0,207	
	Check 1	0,17	1,09	0,010	0,002	0,32	0,04	0,07	0,01	0,030	0,080	0,005	0,002	0,0000	0,003	0,0017	0,007	0,010	0,209	
	Check 2	0,19	1,09	0,010	0,002	0,32	0,04	0,07	0,01	0,030	0,080	0,005	0,001	0,0000	0,003	0,0017	0,006	0,009	0,209	
	185654 030003385979	0,18	1,07	0,010	0,002	0,29	0,04	0,06	0,01	0,028	0,080	0,003	0,001	0,0001	0,001	0,0014	0,004	0,005	0,191	
	Check 1	0,17	1,09	0,010	0,001	0,29	0,04	0,06	0,01	0,029	0,080	0,002	0,002	0,0001	0,002	0,0012	0,004	0,006	0,192	
	Check 2	0,17	1,08	0,010	0,001	0,28	0,04	0,06	0,01	0,029	0,080	0,002	0,002	0,0001	0,002	0,0011	0,004	0,006	0,191	



EC: Elementos Combinados:

Ensaio de Tração

Direção do Corpo Prova: Longitudinal

Temperatura: Ambiente

Espessura da parede: 5,16 mm

Medida L0: L0=2"

Método LE: Along.Total Sob Carga 0,50 %

		Corpo de Prova	Área (MM ²)	LE (MPA)	RT (MPA)	AL (%)
	Especificado: Min			290	415	21
	Max					
Corrida Lote Controle						
	184956 030003360875	TIRA LARGURA 19,05 MM	104,5	347	512	34
	185654 030003385979	TIRA LARGURA 19,05 MM	102,9	369	523	34

LE-Limite de Escoamento; RT-Resistência a Tração; AL-Alongamento;

O CERTIFICADO ORIGINAL DO FORNECEDOR FABRICANTE ENCONTRA-SE EM NOSSOS ARQUIVOS PARA CONSULTA

08 JUN 2021
IMEFER Industrial e Mercantil de Ferragens Ltda

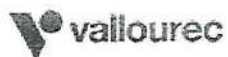

Certificado de Inspeção

(De acordo com DIN EN 10204.3.1)

Nº.: 0050739775 / 00

Folha: 3 / 3

Ensaio de Dureza

Escala: HV

		Min
Especificado: Min		
Max		248,0
Corrida	Lote Controle	
184956	030003360875	170,0
185654	030003385979	158,0



Observações:

NOTA FISCAL: 000198298

O CERTIFICADO ORIGINAL DO FORNECEDOR FABRICANTE ENCONTRA-SE EM NOSSOS ARQUIVOS PARA CONSULTA

08 JUN 2021

IMEPEL Industrial e Mercantil de Ferragens Ltda

Certificamos que este material foi produzido e inspecionado de acordo com todas as exigências destas normas e especificações, e todos os resultados considerados satisfatórios. Este Certificado é processado por sistema informatizado e é válido sem assinatura.

DEPARTAMENTO DE CONTROLE DE QUALIDADE

FAX: (55-31) 3328-2773

e-mail: luz.silva@vallourec.com

DATA
09.06.2020

ENG. LUIZ FERNANDO DA SILVA - CREA-MG 58834-D
RESPONSÁVEL TÉCNICO

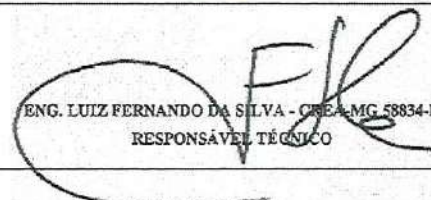

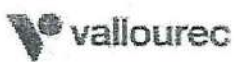

Vallourec Soluções Tubulares do Brasil S.A.
Usina Barreiro - Av. Olinto Meireles, 65
Barreiro de Baixo - CEP: 30640-010



Certificado de Inspeção

(De acordo com DIN EN 10204.3.1)

Nº.: 0050756585 / 00

Folha: 1 / 3

Cliente: IMEFER-INDL E MERCANTIL DE FERRAGENS LTDA.

País: Brasil

Cod.Material: 388910

Pedido Usina: 580010 / 10

Pedido Cliente: P12-202853

Num.Material Cliente (NCM): 020818



TB11-21
112+2035

Inspeção: VALLOUREC SOL.TUBULARES BRASIL S.A BARREIRO

DESCRIÇÃO DO PRODUTO: TUBO DE AÇO SEM COSTURA, LAMINADO À QUENTE, PONTA CHANFRADA 37,5 GR., LAMINADO

DIMENSÕES: 168,30 mm X 7,10 mm GRAU DO AÇO: B # B # B

NORMAS: API SPEC 5L, 04.2018, 46TH EDITION - PSL 1

ATENDE TAMBÉM ÀS NORMAS: ASTM A 106M - 19 A ASTM A 530M - 18 # ABNT NBR 6321.04.2011

PROTEÇÃO SUPERFICIAL: EXTERNA: SEM PROTECAO PROTEÇÃO DE PONTAS: SEM PROTEÇÃO

TOLERÂNCIAS: DIÂMETRO EXTERNO(CORPO TUBO): -0,80 mm / +1,26 mm PAREDE: -0,89 mm / +1,08 mm

TOLERÂNCIAS(PONTAS): DIÂMETRO EXTERNO: -0,40 mm / +1,60 mm

COMPRIMENTO: FAIXA 5000,00 mm - 7000,00 mm

MARCAÇÃO DE NORMA: Estencilado no corpo do tubo: FABRICANTE API Spec 5L-0150.4 MONOGRAMA API MÊS/ANO ASTM A 106M/ABNT NBR6321 168,30 X 7,10 B/B/B PSL1 SMLS NÚMERO DA CORRIDA COMPRIMENTO 12400 KPA SCH 040 PESO Segurança LOGO TIPO ABNT/INMETRO 002197/2018 002481/2018 LOGO VSB

Corrida	Amarrado	Peças	Comprimento(m)	Peso (Kgf)
188043	8002024143	10	66,42	1907
188581	8002024150	10	62,69	1823
	8002024152	10	62,71	1820
	8002024158	10	60,90	1777
	8002024202	10	63,28	1845
	8002024204	10	63,00	1842
	8002024207	10	64,33	1879
	PCA6190040	10	62,34	1827
Total		80	505,67	14720

O CERTIFICADO ORIGINAL DO FORNECEDOR FABRICANTE ENCONTRA-SE EM NOSSOS ARQUIVOS PARA CONSULTA
25 JAN 2021
IMEFER Industrial e Mercantil de Ferragens Ltda

O PRODUTO FOI APROVADO NOS SEGUINTES TESTES/INSPEÇÕES: DIMENSIONAL # VISUAL # TESTE HIDROSTÁTICO: 12400,0 KPA 5 S # MAGNETISMO RESIDUAL: MAX 30 GAUSS #

CHAPA
FABRICANTE: A108 VALLOUREC
ESPECIE: A108 B
ESPEC: 7,10
DIAM.: 168,30
COMPRIM.: 40
Nº DE VOLUME: 188581
PRESSÃO DE TESTE

JOHNSON CONTROLS
Fornecedor: Imefer
99919
DATA: 11/02/21
NR: TB11-21
ITEM: 112 F2015
2019
Inspeção Recebimento



Certificado de Inspeção

(De acordo com DIN EN 10204.3.1)

Nº.: 0050756585 / 00

Folha:2 / 3

Composição Química (%)

Processo: Forno básico a oxigênio, aço acalmado

Ceq: C+Mn/6+(Cr+Mo+V)/5 +(Ni+Cu)/15

EC1: Nb + V

EC2: Nb + V + Ti

EC3: Cr + Cu + Mo + Ni + V

		C	Mn	P	S	Si	Ni	Cr	Mo	Al	Cu	V	Nb	B	Ti	Ca	Ceq	EC1	EC2	EC3	
Análise de Corrida	Min		0,290			0,100															
	Max	0,270	1,060	0,030	0,030		0,400	0,400	0,150		0,400	0,060		0,0010	0,040		0,430	0,060	0,150	1,000	
Análise de Produto	Min		0,290			0,100															
	Max	0,270	1,060	0,030	0,030		0,400	0,400	0,150		0,400	0,060		0,0010	0,040		0,430	0,060	0,150	1,000	
Corrida	Lote																				
	188043	030003503292	0,10	1,01	0,010	0,001	0,24	0,04	0,06	0,02	0,027	0,060	0,003	0,019	0,0000	0,002	0,0009	0,292	0,022	0,022	0,183
		Check 1	0,10	1,03	0,010	0,001	0,24	0,04	0,07	0,02	0,030	0,060	0,004	0,019	0,0002	0,002	0,0012	0,299	0,023	0,023	0,194
		Check 2	0,10	1,02	0,010	0,001	0,24	0,04	0,07	0,02	0,030	0,060	0,004	0,019	0,0002	0,002	0,0013	0,296	0,023	0,023	0,194
	188581	030003502710	0,19	0,54	0,010	0,003	0,21	0,05	0,08	0,02	0,023	0,150	0,001	0,000	0,0000	0,001	0,0015	0,314	0,001	0,001	0,301
		Check 1	0,19	0,54	0,011	0,002	0,20	0,05	0,09	0,02	0,025	0,140	0,000	0,001	0,0001	0,001	0,0015	0,319	0,001	0,001	0,300
		Check 2	0,19	0,54	0,011	0,004	0,20	0,05	0,09	0,02	0,025	0,140	0,000	0,001	0,0001	0,001	0,0015	0,318	0,001	0,001	0,300



Ceq: Carbono Equivalente; EC: Elementos Combinados;

Ensaio de Tração

Direção do Corpo Prova: Longitudinal

Temperatura: Ambiente

Espessura da parede: 7,10 mm

Medida L0: L0=2"

Método LE: Along. Total Sob Carga 0,50 %

	Corpo de Prova	Área (MM ²)	LE	RT	AL	
			(MPA)	(MPA)	(%)	
			245	415	26	
Corrida	Lote					
	188043	030003503292	TIRA LARGURA 25,4 MM	322	462	39
	188581	030003502710	TIRA LARGURA 25,4 MM	323	470	37

O CERTIFICADO ORIGINAL DO FORNECEDOR FABRICANTE ENCONTRA-SE EM NOSSOS ARQUIVOS PARA CONSULTA

MEFER Industrial e Mercantil de Ferragens Ltda

LE-Limite de Escoamento; RT-Resistência a Tração; AL-Alongamento;

Observações:

NOTA FISCAL: 000227102

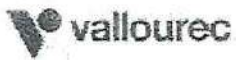

Certificado de Inspeção

(De acordo com DIN EN 10204 3.1)

Nº.: 0050756585 / 00

Folha: 3 / 3



O CERTIFICADO ORIGINAL DO FORNECEDOR FABRICANTE ENCONTRA-SE EM NOSSOS ARQUIVOS PARA CONSULTA

25 JAN 2021

IMEFER Industrial e Mercado de Ferragens Ltda

Certificamos que este material foi produzido e inspecionado de acordo com todas as exigências destas normas e especificações, e todos os resultados considerados satisfatórios. Este Certificado é processado por sistema informatizado e é válido sem assinatura.

DEPARTAMENTO DE CONTROLE DE QUALIDADE

FAX: (55-31) 3328-2632

e-mail: sergio.lopes@vallourec.com

DATA
16.12.2020

SÉRGIO RICARDO SILVA LOPES - CREA/MG 60498
RESPONSÁVEL TÉCNICO



Vallourec Soluções Tubulares do Brasil S.A.
 Distrito Industrial, s/n - Jeceaba - MG - CEP: 35498-000 - Brasil

Certificado de Inspeção
 (De acordo com DIN EN 10204.3.1)
 Nº: 0030049222 / 00 Folha 1 / 2

Cliente: IMEFER-INDL E MERCANTIL DE FERRAGENS LTDA.

País: Brasil

Cod.Material: 705386

Pedido Usina: 591624 / 10

Pedido Cliente: P05-202938

Num.Material Cliente (NCM): 020818



Inspeção: Vallourec Soluções Tubulares do Brasil S.A.

PRODUTO: TUBO DE AÇO SEM COSTURA, LAMINADO À QUENTE, LAMINADO, PONTA CHANFRADA 37,5 GR., (Ângulo do Chanfro-Mínimo: 35,0 grau, Ângulo do Chanfro-Máximo: 40,0 grau). (Base de Chanfro-Mínimo: 0,80 mm, Face do Chanfro - Máximo: 2,40 mm)
DIMENSÕES: 168,30 mm X 7,11 mm GRAU DO AÇO: B # B # B #
NORMAS: API SPEC 5L, 04.2018, 46TH EDITION - PSL 1
ATENDE TAMBÉM ÀS NORMAS: ASTM A106M - 19 # A # ASTM A 530M - 18 # ABNT NBR 6321, 06.2020
PROTEÇÃO SUPERFICIAL: EXTERNA: SEM PROTEÇÃO INTERNA: SEM PROTEÇÃO PROTEÇÃO DE PONTAS: CAPA DE POLIETILENO COM FURO
TOLERÂNCIAS: DIÂMETRO EXTERNO(CORPO TUBO): $\pm 0,80$ mm / $\pm 1,26$ mm **PAREDE:** $-0,89$ mm / $+1,07$ mm
TOLERÂNCIAS(PONTAS): DIÂMETRO EXTERNO: $-0,40$ mm / $+1,60$ mm
COMPRIMENTO: FAIXA 5000,00 mm - 7000,00 mm
MARCAÇÃO DE NORMA: PAINT STENCILED: MANUFACTURER API Spec 5L 0867 API MONOGRAM MONTH/YEAR ASTM A-106M / ABNT NBR 6321 168.30 X 7,11 B/B PSL1 SMLS-HEAT-NUMBER
 LENGTH WEIGHT PIPE TALLY NO 12,4 MPA SCH 040 Segurança ABNT LOGO INMETRO 002488/2018 002483/2018 VSB LOGO 591624/10

+B075-21
 1112+2035

Corrida	Peças	Comprimento(m)	Peso (Kgf)
191452	76	520,08	14764
Total	76	520,08	14764

O PRODUTO FOI APROVADO NOS SEGUINTE TESTES/INSPEÇÕES: DIMENSIONAL # VISUAL # TESTE HIDROSTÁTICO: 12,4 MPA 5 S # MAGNETISMO RESIDUAL MÁXIMO : 30 GAUSS #

CHAPA TUBO

FABRICANTE Vallourec

ESPECIF. A-106 GRAU B

ESPESS. 7,11

DIAM. 168,30 SCH 040

COMPRIM. 6,78 CORRIDA 191452

Nº DE VOLUME _____

TESTES DE TESTE _____

JOHNSON CONTROLS

Fornecedor: IMEFER

Nº: 0103738 DATA: 20/07/2021

Nº: TB075-21 ITEM: 1112+2035

Em conformidade com a ASME

SA 106 Ed: 2021 Ad: _____

Inspetor Recebimento

O CERTIFICADO ORIGINAL DO FORNECEDOR FABRICANTE ENCONTRA-SE EM NOSSOS ARQUIVOS PARA CONSULTA

11/05/2021

IMEFER Industrial e Mercantil de Ferragens Ltda

Composição Química (%)

Forno Elétrico a Arco, aço acalmado

Ceq: C + Mn/6 + (Cr + Mo + V)/5 + (Ni + Cu)/15		DI:															EC1: Nb + V			EC2: Nb + V + Ti		
EC3: Cr + Cu + Mo + Ni + V		C	Mn	P	S	Si	Ni	Cr	Mo	Al	Cu	V	Nb	B	Ti	Ca	Ceq	EC1	EC2	EC3		
Análise de Corrida	Min		0,29			0,10																
	Max	0,250	1,35	0,030	0,0300		0,40	0,40	0,150		0,40	0,080		0,0010			0,43	0,06	0,15	1,00		
Análise de Produto	Min		0,29			0,10																
	Max	0,250	1,35	0,030	0,0300		0,40	0,40	0,150		0,40	0,080		0,0010			0,43	0,06	0,15	1,00		
Corrida	IPPN																					
191452	Ladle	0,182	1,02	0,013	0,0014	0,22	0,05	0,10	0,035	0,029	0,12	0,021	0,000	0,0002	0,002	0,0011	0,39	0,02	0,02	0,33		
Check 1	301011	0,180	1,00	0,012	0,0011	0,22	0,05	0,10	0,034	0,030	0,12	0,021	0,000	0,0001	0,002	0,0013	0,39	0,02	0,02	0,32		
Check 2	301023	0,192	1,01	0,012	0,0011	0,22	0,05	0,10	0,034	0,032	0,12	0,021	0,000	0,0001	0,002	0,0019	0,40	0,02	0,02	0,32		



Ceq: Carbono Equivalente; EC: Elementos Combinados;

Ensaio de Tração

Direção do Corpo Prova: Longitudinal Temperatura: Ambiente Corpo de Prova TIRA LARGURA 25,4 MM Espessura da parede: 7,11 mm
Medida L0: L0= 50MM Método LE: Along.Total Sob Carga 0,50 %

		LE	RT	AL
		(MPA)	(MPA)	(%)
Especificado: Min		245	415	24
Max				
Corrida	IPPN	Posição		
191452	301011	Pé	421	562
			34	

LE-Limite de Escoamento; RT-Resistência a Tração; AL-Alongamento;

Observações:

O CERTIFICADO ORIGINAL DO FORNECEDOR FABRICANTE ENCONTRA-SE EM NOSSOS ARQUIVOS PARA CONSULTA
15 JUL 2021
IMEFER Industrial e Mercantil de Ferragens Ltda

Certificamos que este material foi produzido e inspecionado de acordo com todas as exigências destas normas e especificações, e todos os resultados considerados satisfatórios. Este Certificado é processado por sistema informatizado e é válido sem assinatura.

DEPARTAMENTO DE CONTROLE DE QUALIDADE
FAX: (55-31) 2141 5365
e-mail: carlos.horta@vstubos.com

CARLOS EDUARDO LIMA HORTA
RESPONSÁVEL TÉCNICO

DATA
19.06.2021

USIMINAS

USINAS SIDERÚRGICAS DE MINAS GERAIS S.A.
 USINA INTENDENTE CÂMARA - IPATINGA/MG/BRASIL
 SEDE: BELÓRIZONTE - MG - BRASIL
 R. PROF. JOSÉ VIEIRA DE MENDONÇA, 3011
 BAIRRO ENGENHO NOGUEIRA - CP 806 - CEP: 31310-260
 CNPJ: 60.894.730/0025-82
 INSCRIÇÃO ESTADUAL: 313.002022.0120

CERTIFICADO DE INSPEÇÃO
INSPECTION CERTIFICATE
CHAPA GROSSA DO LCG
STEEL PLATE

Cliente-Customer: FERCOI S A

Nota Fiscal
Commercial Invoice

Data de Emissão
Date of Issue

Tolerâncias - Tolerances
 Espessura-Thickness
 Largura-Width
 Comprimento-Length

-0.25/+1.78 mm
 -0.00/+180.00mm
 -6.00/+48.00mm

N 000853935 1

29/06/2020

Ordem de Venda
Sale Order

Nº Certificado
Certificate N°

Nº

Item

5331241

Folha - Sheet = 1

00496304

45

A Usiminas certifica que os produtos discriminados foram fabricados no Brasil pelo processo de oxigênio básico (LD), ensaiados e analisados de acordo com as especificações técnicas aplicáveis. A Usiminas disponibiliza, através do endereço eletrônico "http://certificado.usiminas.com.br:9080/clientes/certificado/RequisicaoCertificado.asp", uma ferramenta de verificação da autenticidade dos certificados de seus produtos. Para sua segurança, recomendamos a utilização desse recurso. Usiminas certifies that the products herein described have been produced in Brazil by using the basic oxygen process (LD), tested and analyzed according to the applicable technical specifications. Usiminas makes available, by using the following website "http://certificado.usiminas.com.br:9080/clientes/certificado/RequisicaoCertificado.asp", a tool to be used by the customer to verify/check product certificate authenticity. Usiminas also recommends the use of such tool for customer's safety.

Qualidade - Steel
ASTM-A516-17-70

Dimensões Nominais - Nominal Dimensions
37,50 x 2440,0 x 12000 mm

Borda - Edge / Oleamento - Oiling
NAO APARADA E NAO OLEADA
MILL EDGE AND DRY

Aparência Superficial - Surface Appearance
SUPERFÍCIE COMERCIAL
COMMERCIAL SURFACE

Placa Volume Slab Package	Peças por Volume Pieces per Packages	Massa Líquida Net Mass	Massa Bruta Gross Mass	Corrida Amostra Heat Sample
282 850358917*	1	9280	9280	434046 56301006

Massa Líquida Real Total-Total Actual Net Mass = 9,280 t
 Massa Bruta Real Total-Total Actual Gross Mass = 9,280 t
 Peças-Pieces = 1 Volumes = 1

Ensaio de Tração - Tensile Test

Amostra Sample	Pos YS	Dir C	LE 308	LR 503	LE/LR(%) 61	AL(%) 25
56301006	BB	C	308	503	61	25

Unidade-Unit = N/mm²
 Método de Ensaio LE-Test Method YS = 0,2%
 BM = 200 mm Larg = 38,1 mm S = Retangular

Composição Química (%) - Chemical Composition (%)

Corrida Análise Heat Analysis	C	Si	Mn	P	S	Al	Cu	Nb	V	Ti	Cr	Ni	Mo	Sn	N	As	B	Ca	Sb	Pb
434046 P	0,21	0,20	1,03	0,020	0,003	0,034	0,00	0,002	0,003	0,004	0,02	0,02	0,02	0,001	0,0039	0,006	0,0001	0,0003	0,002	0,003

Condição de Fornecimento - Supply Condition

COMO LAMINADO - AS ROLLED

Abreviaturas - Abbreviations

* = Volume Amostrado-Mother Plate
 LR = Limite de Resistência - TS = Tensile Strength
 Dir = Direção-Direction
 Pos = Posição de Amostragem-Sampling Position
 BM = Base Medida-Gauge Length
 S = Seção Transversal-Cross Section
 Al = Alumínio Total-Total Aluminum

Abreviaturas - Abbreviations

LE = Limite de Escoamento - YS = Yield Strength
 AL = Alongamento - El = Elongation
 C = Transversal-Transverse
 BB = Base na borda-Bottom at edge
 Larg = Largura-Width Diam = Diâmetro-Diameter
 P = Panels-Ladle

CHAPA
 FABRICANTE **Usiminas**
 ESPEC. **A-516**
 ESPES. **37,50**
 DIAM. **70**
 COMPR. **434046**
 Nº DE VOLUME **850358917**
 PRESSÃO DE TESTE

System of Quality Control and Inspection
 Management System for controlling the
 production
 ISO 9001
 ISO 14001
 OHSAS 18001
 OHSAS 18004
 Produto Conforme
 Conforms Product
 Controlado e Registrado
 Controlled and Registered
 Produto de Qualidade
 Quality Product

FORNECEDOR: FERCOI S.A.
 Nº: 291659
 Nº: CH0728-21
 DIA 14/04/2021
 112219855
 2019
 SA 516
 Inspetor de Inspeção

Certificado do tipo 3.1 da norma EN-10204. Certificate of the type 3.1 of the EN-10204.
 Certificamos que este material foi inspecionado e possui nível de radiação abaixo de 1 kBq/kg. We certify that this material has been inspected and the radiation level is less than 1 kBq/kg.
 Conteúdo local de 100% conforme CERTIFICADO DE CONTEÚDO LOCAL Nº 003-06-00357/2016 DNV.GL.

Observações - Remarks

PROGRAMAÇÃO JUNHO/2020

FDS - Ficha de Dados de Segurança do Produto, disponível na Extranet da Usiminas

MSDS - Material Safety Data Sheet available at Usiminas Extranet

Helber Luiz Oliveira Ribeiro
 helber.ribeiro@usiminas.com
 +55 031 3829-3215

GERENTE GERAL CONTROLE INTEGRADO DE QUALIDADE
 INTEGRATED QUALITY CONTROL GENERAL MANAGER

VISTORIADOR
 SURVEYOR



CERTIFICADO DE QUALIDADE/MILL TEST / QUALITY CERTIFICATE

BR-ML-OURO BRANCO-CHAPA GROSSA
 RCD MG 443 KM 7
 FAZENDA DO CADETE
 OURO BRANCO MG
 36420-000
 BRASIL

JA	PEDIDO CLIENTE/CUSTOMER ORDER 2022	ORDEM VENDA/SALES ORDER 5710868-10	PÁG/PAGE 1 / 1
PRODUTO/PRODUCT Chapa Grossa / Plate		DIMENSÕES/DIMENSIONS 6.30mm x 2500mm x 12000mm	NÚM. CQ/QC. NÚM 810F786527-10
NORMA TÉCNICA DO AÇO/SPECIFICATION ASTM A516 GR70		TIPO DE BORDA/EDGE TYPE Aparada / Cut edge	DATA/DATE 17.11.2017
		CONDIÇÃO DE FORNECIMENTO/DELIVERY CONDITION Como Laminado / As rolled	NF/INVOICE 000954922

ID VOLUME/VOLUME ID	CHAPA MÃE/MOTHER PLATE	PESO/WEIGHT (KG)	CORRIDA/HEAT	AMOSTRA/SAMPLE
3707520903	NÃO/NO	1.495	28096070	28096070011
3707521201	SIM/YES	1.495	28096070	28096070006
3707521203	NÃO/NO	1.495	28096070	28096070006

COMPOSIÇÃO QUÍMICA/CHEMICAL COMPOSITION												
CORRIDA/HEAT	C(%)	Mn(%)	Si(%)	P(%)	S(%)	Al T(%)	Cr(%)	Cu(%)	Ti(%)	Mo(%)	Nb(%)	Ni(%)
28096070	0,23	1,04	0,19	0,018	0,007	0,027	0,02	0,01	0,002	0,01	0,001	0,01
	V(%)	B(%)	Ca(%)									
28096070	0,004	0,0050	0,0001									

TRAÇÃO / TENSILE TEST						
AMOSTRA/SAMPLE	DIREÇÃO/DIRECTION	POSIÇÃO/POSITION	LE/YP (MPa)	LR/TS (MPa)	LE/LR	ALONG/ELONG(%)
28096070006	Transversal	Borda / Corner	385	545	0,71	33,0
28096070011	Transversal	Borda / Corner	385	554	0,68	32,0

OBSERVAÇÕES/REMARKS

Todas as fontes de radiação são monitoradas e controladas. Toda sucata utilizada no processo de fabricação do aço na usina de Ouro Branco é gerada internamente. Certificamos que este material é isento de contaminação por radiação. All radiation sources are verified and controlled. All scrap used at Gerdau Ouro Branco is internally generated. We certify that this material is free of contamination by radiation.

FABRICANTE: **GERDAU**
 ESPECIF: **A-516**
 Nº DE VOLUME: **70**
 PRESSÃO DE TESTE: **6,3**
 CONFIRM: **2809070**

A Gerdau S.A. certifica que o material aqui descrito está de acordo com as especificações técnicas aplicáveis. Como proteção mútua para cliente e fornecedor, este certificado é considerado como confidencial e não pode ser transcrito ou reproduzido sem a autorização por escrito da Gerdau S.A.

Gerdau S.A. certifies that the material herein described is in accordance with the applicable technical specifications. As mutual protection for customer and supplier, this certificate is considered as confidential and can not be transcribed or reproduced without the written authorization of Gerdau S.A.

GERENTE DE QUALIDADE/QUALITY MANAGER: **KENJI CAMEY**
 CRER 43236
 VISTORIADOR/SUPERVISOR: **SA 516**

JOHNSON CONTROLS
 Fornecedor: **FERCO I S/A**
 Nº: **291659**
 Nº: **CH029-21**
 Data: **14/04/2021**
 Nº: **412219955**
 SA **516**

944A0445J13FRS

APROVADO PARA FABRICAÇÃO

19,02,21

Ass. 

TIPAR RASTREABILIDADE DA MATERIA PRIMA, ESPECIFICAÇÃO E GRAU DO MATERIAL (SA-106-B)



UM LADO COM ROSCA 3/4" NPT NO EXTERIOR DO TUBO

25 PC
 PC=374629/2
 PE=28/02/21
 01/04/21



NOTAS:

- 1- TODAS AS DIMENSÕES ESTÃO EM MILÍMETROS, EXCETO ONDE INDICADO
- 2- ROSCAS CÔNICAS CONFORME ASNI/ASME B1.20.1

MATERIAL: TUBO 3/4" SCH 160 SA-106-B ULTIMA VERSÃO, COM CERTIFICADO DE MATERIA PRIMA
 PESO APROXIMADO: 0,7 kg

QUADR.	REV.	ECN/NAE	DESCRIÇÃO DA REVISÃO	DES.	DATA DES.	VER.	DATA VER.	APR.	DATA APR.
0		BR20-0264	EMISSÃO INICIAL (FRICK REV.:A)	GCS	22/01/2021	AA	22/01/2021	LRM	22/01/2021

HISTÓRICO DE REVISÕES

CLIENTE:	TÍTULO:
Nº PEDIDO:	TUBO 3/4" SCH 160 X 229
PROJETO:	C/ UMA PONTA ROSCA NPT
FORMATO: A4	ESCALA: 1 : 2
SUBSTITUI DESENHO:	$\phi 26,7 \times \phi 15,5 \times 229$
ACABAMENTO E TOLERÂNCIA CONF.: 17-00.213-DE-PR	
 Industrial Refrigeration Latin America Av. Independência, 2757 Sorocaba SP, Brasil	DES. Nº.: 944A0445J13FR
	REV.: 0
	FOLHA Nº. 1/1

ESTE DESENHO É DE PROPRIEDADE DA JOHNSON CONTROLS DAQUI DO BRASIL LTDA. E, PODERÁ SER ALTERADO SEM PRÉVIO AVISO. É PROIBIDA A REPRODUÇÃO TOTAL OU PARCIAL POR QUALQUER MEIOS SEM A PRÉVIA AUTORIZAÇÃO DA EMPRESA POR ESCRITO.



Relatório de Resultado de Inspeção Dimensional

FQ 28 REV. 01
 Inspeção Nº: 1585
 Início:
 Fim:
 Pág: 1 de 1

CLIENTE: JOHNSON CONTROLS BE DO BRASIL LTDA. OS: 2549/001
 PEÇA: TUBO Ø 26,7 X Ø 15,5 X 229, A106B Qtde: 25
 Nº DESENHO: 944A0445J13FR PEDIDO DE COMPRA: 377629/2 Peça Nº: 2549/001

Inspeção Visual: Rugosidade:
 Trat. Térmico: Dureza: Trat. Superficial:

INSPEÇÃO DIMENSIONAL

ITEM	ESPECIFICAÇÃO	TOLERÂNCIA		ENCONTRADO	
		MIN	MAX	MIN	MAX
1	(26,7)			26,67	26,72
2	(15,5)			15,50	15,57
3	3/4"NPT			OK	OK
4	229	-1,5	+1,5	229,15	229,32

OBSERVAÇÕES

RNC: CONCLUSÃO: APROVADO

Cliente	Supervisor JJ	Inspetor NICKOLAS GOES
---------	---------------	------------------------

JOHNSON CONTROLS
 Fornecedor: JJ USINAGEM
 Nº: 29156 DATA: 18/03/2021
 Nº: 187394 Nº: 944A0445J13FRS
 A 106 Ed: 2019 Ad:
 Inspeção Dimensional

ITEM 944A0445J13FRS
 FABRICANTE ACO TUBO
 ESPECIE A-106 SCH. B
 DIAM. 3/4" SCH. 160
 CORRIDA 187394
 RATING



Certificado de Conformidade
Certificate of conformity / Certificado de conformidad

Nº Certificado 293710
N.Certificate / N.certificado

Cliente USINAGEM JJ LTDA
Client / Cliente

Nota Fiscal 559041
Invoice / Nota Fiscal

Emissão 18/03/2021
Emission / Emisión

Item Descrição do Produto
Item / Artículo Product Description / Descripción del producto

NORMA Pedido OP
Standard/estándar Order / Solicitud Production order / Orden de producción

1	TUBO S/C COND RED API 5L / A106 / NBR6321 1.1/2" SCH80 LG COR x 5,08 mm MNA N X 1000 mm-pcs/kg	API 5L	*168121																							
Certificado de Usina Mill certificate / Certificado de Usina		50730645																								
Corrida da Usina Heat Number/Rastreo de la planta		184070																								
Análise Química (%) Chemical analysis/Análisis Químico		Propriedades Mecânicas Mechanical property / Propiedad Mecánica																								
C	Mn	P	S	Si	Cr	Ni	Mo	Al	Cu	V	Ti	Pb	Nb	Co	B	Ca	LR	LE	AL	DURHB	DURHB2	RA	TH	LOTE	Quant.	
.2	.52	.01	.005	.22	.05	.03	.01	.027	.04		.001				.0001	.0011	463	340	33					17	0109864	5.4

2	TUBO S/C COND RED ASTM A106 / NBR6321 1 1/4" XXS PTLG COR x 9,7 mm MNA N X 1000 mm-pcs/kg	ASTM A106	*168121																						
Certificado de Usina Mill certificate / Certificado de Usina		50762577																							
Corrida da Usina Heat Number/Rastreo de la planta		189544																							
Análise Química (%) Chemical analysis/Análisis Químico		Propriedades Mecânicas Mechanical property / Propiedad Mecánica																							
C	Mn	P	S	Si	Cr	Ni	Mo	Al	Cu	V	Ti	Pb	Nb	Co	B	Ca	LR	LE	AL	DURHB	DURHB2	RA	TH	LOTE	Quant.
.2	.52	.011	.004	.21	.09	.03	.02		.02	0							470	319	37					014451	0

3	TUBO S/C COND RED ASTM A106 3/4" SCH160 PT N-m/kg	ASTM A106	*168121																						
Certificado de Usina Mill certificate / Certificado de Usina		50760591																							
Corrida da Usina Heat Number/Rastreo de la planta		187354																							
Análise Química (%) Chemical analysis/Análisis Químico		Propriedades Mecânicas Mechanical property / Propiedad Mecánica																							
C	Mn	P	S	Si	Cr	Ni	Mo	Al	Cu	V	Ti	Pb	Nb	Co	B	Ca	LR	LE	AL	DURHB	DURHB2	RA	TH	LOTE	Quant.
.19	.53	.01	.002	.21	.08	.03	.03		.07	.001							463	297	47					0138178	18.5

4	ACO LAM RED SAE 4140 1.7/8" GNA N COR X 1500 mm-pcs/kg	SAE 4140	*163121																						
Certificado de Usina Mill certificate / Certificado de Usina		130297																							
Corrida da Usina Heat Number/Rastreo de la planta		23080707																							
Análise Química (%) Chemical analysis/Análisis Químico		Propriedades Mecânicas Mechanical property / Propiedad Mecánica																							
C	Mn	P	S	Si	Cr	Ni	Mo	Al	Cu	V	Ti	Pb	Nb	Co	B	Ca	LR	LE	AL	DURHB	DURHB2	RA	TH	LOTE	Quant.
.396	.79	.02	.006	.25	.83	.12	.16	.009	.15	.005	.004	.003	.004	.006	.0065	.0003	1022	715	9.3	302			21.2	0140222	21



HCI - Hidráulica, Conexões Industriais Ltda.
 A NOSSA MELHOR CONEXÃO COM VOCÊ.
CERTIFICADO DE QUALIDADE Nº 40607905
 MILL TEST CERTIFICATE / CERTIFICADO DE CALIDAD
 EN 10204-3.1



CLIENTE / CUSTOMER / CLIENTE:

JOHNSON CONTROLS BE DO BRASIL LTDA

PEDIDO CLIENTE / CUSTOMER ORDER / REF. CLIENTE:

383865

ITEM	QTD. QUANTY CANT	DESCRIÇÃO / DESCRIPTION / DESCRIPCION	ESPECIFICAÇÃO SPECIFICATION ESPECIFICACION	CORRIDA HEAT COLADA	NORMA DIMENSIONAL DIMENSIONAL STANDARD NORMA DIMENSIONAL
5	1	MEIA LUVA 3000 NPT DN 3/4 A/SA105 IT. 5	A/SA-105/19	BJB	ASME B 16.11/16

COMPOSIÇÃO QUÍMICA / CHEMICAL COMPOSITION / COMPOSICION QUIMICA

ITEM	C%	Min%	P%	S%	Si%	Cr%	Ni%	Mo%	Cu%	V%	Nb%	N%	Ti%	CE%
5	0,21	1,32	0,007	0,01	0,19	0,15	0,17	0,05	0,02	0,01				

ITEM	Corpo de Prova Specimen Probeta		PROPRIEDADES MECÂNICAS / MECHANICAL PROPERTIES / PROPIEDADES MECÂNICAS					MATERIAL DE PARTIDA RAW MATERIAL MATERIA PRIMA	RASTREAB. HCI HCI HEAT TRAZABILIDAD HCI
	FORMA SHAPE FORMA	DIREÇÃO DIRECTION DIRECCION	LIMITE DE ESCOAM. YIELD POINT LIMITE DE FLUENCIA (MPa)	LIMITE DE RESISTÊNCIA TENSILE STRENGTH CARGA DE ROTURA (MPa)	ALONGAMENTO ELONGATION ALARGAMIENTO (%)	ESTRICAÇÃO REDUCTION OF AREA ESTRICCION (%)	TR TÉRMICO HEAT TREATMENT TR. TERMICO		
5			344	560	31,00	65,00	ST	160e163	H21-6915

TESTE DE IMPACTO / IMPACT TEST / ENSAYO DE IMPACTO

ITEM	A (JOULE)	B (JOULE)	C (JOULE)	MÉDIA AVERAGE PROMEDIO (JOULE)	°C	ITEM	A (JOULE)	B (JOULE)	C (JOULE)	MÉDIA AVERAGE PROMEDIO (JOULE)	°C
5											

Observações: REMARKS OBSERVACIONES

Fornecedor: **HCI**
 NF: **128455** DATA: **27/08/21**
 NR: **BJB** ITEM: **1342 + 1545**
 SA **105** Ed: **2021** Ad:
 Em conformidade com a ASME

FABRICANTE: **QUALITEC**
 ESPECIF. **SA-105**
 DIAM. **3/4**
 CORRIDA: **BJB**
 RATING: **3000**

NOTA: Conexões S/A-234 WPB/W Sem Tratamento Térmico, foram conformadas a quente entre 620°C e 980°C. Os produtos declarados estão aprovados.
 NOTE: Fittings S/A-234 WPB/W Without Heat Treatment, were hot formed 620°C to 980°C. The products indicated were approved.
 Conexiones S/A-234 WPB/W Sin Tratamiento Térmico, se fabricaron en el rango 620°C a 980°C. Los productos indicados son aprobados.

ST - SEM TRATAMENTO TÉRMICO WITHOUT HEAT TREATMENT SIN TRATAMIENTO TERMICO	RE - RECOZIDO ANNEALED RECOCIDO	NT - NORMALIZADO TEMPERADO E REVENIDO NORMALIZED QUENCHED AND TEMPERED NORMALIZADO TEMPLADO Y REVENIDO	AT - ALIVIO DE TENSÃO STRESS RELIEVED ALIVIO DE TENSION	RI - RECOZIMENTO ISOTÉRMICO ISOTHERMAL ANNEALING RECOCIDO ISOTERMICO	Q - QUADRADO STRIP TEST CUADRADO	L - LONGITUDIN LONGITUDIN LONGITUDIN
NO - NORMALIZADO NORMALIZED NORMALIZADO	TR - TEMPERADO E REVENIDO QUENCHED AND TEMPERED TEMPLADO Y REVENIDO	SO - SOLUBILIZADO ANNEALED HIPER TEMPLADO	RV - REVENIDO TEMPERED REVENIDO	NR - NORMALIZADO E REVENIDO NORMALIZED AND TEMPERED NORMALIZADO Y REVENIDO	C - CILÍNDRICO CILINDRICAL CILINDRICO	T - TRANSVERS TRANSVERS TRANSVERS
ES - ESTABILIZADO ESTABILIZED ESTABILIZADO	SE - SOLUBILIZADO E ESTABILIZADO ANNEALED AND STABILIZED SOLUBILIZADO Y ESTABILIZADO	ACABAMENTO DA FACE FLANGE FINISH CONTACT FLANGE ACABADO SUPERFÍCIE DE CONTACTO BRIDA	E - ESPIRAL = 125 - 250 Ra SPIRAL = 125 - 250 Ra ESPIRAL = 125 - 250 Ra	C - CONCÊNTRICO = 125 - 250 Ra CONCENTRIC = 125 - 250 Ra CONCÊNTRICO = 125 - 250 Ra	L - LISO = 125 Ra max SMOOTH = 125 Ra max LISO = 125 Ra max	RJR = 63 Ra m RTJ = 63 Ra m RJ = 63 Ra m



SP - 18/08/2021

APROVADO ELETRONICAMENTE / ELECTRONIC APPROVED / APROBADO POR VIA ELECTRO

DATA / DATE / FECHA

Rua Santana de Ipanema, 948 - Cidade Industrial Satélite São Paulo - Cep 07220-010 - Guarulhos - SP - Brazil - PABX: (55 11) 2413-8080
 Fax Qualidade: 2413-8093 - Fax Vendas: 2413-8088 - E-mail: vendas@hci.ind.br - www.portalhci.com.br

CERTIFICADO DE QUALIDADE / QUALITY CERTIFICATE

No. 1317-A

QUALLITEC CONEXOES INDUSTRIAIS LTDA
 Tel. (11) 2749-7011 - 2749-6764
 Rua do Cádmo, 40 - Cep: 08280-110 - Cidade LIDER - São Paulo - SP
 CNPJ: 25.059.824/0001-91 I.E: 140.988.903.118

Cliente: Customer	45	HCI HIDRAULICA, CONEXOES IND. LTDA	Ped. Cliente: Customer Order	142.544	Nota Fiscal: Invoice	1884	Emissão: Emission	17/05/2021								
Item Classif/ Customer Item	Item/ Item	Corrida Fornecedor/ Heat	Quantidade/ Quantity	Descrição do Material/ Material Description										Norma de Material/ Material Norm	Norma de Produção/ Production Standard	Material de Partida/ Starting Material
1		4839317 #N/D #N/D #N/D #N/D	200	M&A LUVA A105 300DL NPT DN 3/4" H21. 6915										A/S A105/21 #N/D #N/D #N/D #N/D	ASME B16.11/16	BARRA RED. 5AE 1522 58,10 #N/D #N/D #N/D #N/D

Item	Corrida	Quant.	C	Mn	P	S	Si	Ni	Cr	Mo	Cu	V	Nb	Al	Ti	N	Zn	Fe	Sn	Pb	Ca	Ta	W	Li	CO
Item	Running	Quant.	%	%	%	%	%	%	%	%	%	%	%	%	%	%	%	%	%	%	%	%	%	%	%
1	BJB	200	0,210	1,320	0,007	0,010	0,190	0,170	0,150	0,080	0,020	0,010	0,000	0,007	0,000	0,000	0,000	0,000	0,000	0,000	0,000	0,000	0,000	0,000	0,000
			#N/D	#N/D	#N/D	#N/D	#N/D	#N/D	#N/D	#N/D	#N/D	#N/D	#N/D	#N/D	#N/D	#N/D	#N/D	#N/D	#N/D	#N/D	#N/D	#N/D	#N/D	#N/D	#N/D
			#N/D	#N/D	#N/D	#N/D	#N/D	#N/D	#N/D	#N/D	#N/D	#N/D	#N/D	#N/D	#N/D	#N/D	#N/D	#N/D	#N/D	#N/D	#N/D	#N/D	#N/D	#N/D	#N/D
			#N/D	#N/D	#N/D	#N/D	#N/D	#N/D	#N/D	#N/D	#N/D	#N/D	#N/D	#N/D	#N/D	#N/D	#N/D	#N/D	#N/D	#N/D	#N/D	#N/D	#N/D	#N/D	#N/D
			#N/D	#N/D	#N/D	#N/D	#N/D	#N/D	#N/D	#N/D	#N/D	#N/D	#N/D	#N/D	#N/D	#N/D	#N/D	#N/D	#N/D	#N/D	#N/D	#N/D	#N/D	#N/D	#N/D

Teste de Tração/ Traction Test

Item/Item	Norma/Standard	Corpo Prova/ Specimen	Direção Corpo/ Body Direction	Posição Corpo/ Specimen Position	Temperatura/ Temperature	Limite Escoamento/ Flow Limit (MPa)	Limite Resistência/ Resistance Limit (MPa)	Alongamento/ Stretching (%)	Entalhe/ Stitchness (%)	Método/ Method*	Resultado do Teste/ Test Result	Tratamento Térmico/ Heat Treatment
1						344	560	31,00	65	5	160 / 163	SEM TRATAMENTO
0						#N/D	#N/D	#N/D	#N/D	#N/D	#N/D	#N/D
0						#N/D	#N/D	#N/D	#N/D	#N/D	#N/D	#N/D
0						#N/D	#N/D	#N/D	#N/D	#N/D	#N/D	#N/D
0						#N/D	#N/D	#N/D	#N/D	#N/D	#N/D	#N/D

Teste de Impacto/ Impact Test

Item/Item	Norma/Standard	Corpo Prova/ Specimen	Direção Corpo/ Specimen Direction	Posição Corpo/ Specimen Position	Temperatura/ Temperature	Corpo Prova A/ Specimen A	Corpo Prova B/ Specimen B	Corpo Prova C/ Specimen C	Média/ Average	*Legenda Método Dureza: *Legend Method Hardness:
0										0 - Nenhum/ None 5 - HBW
0										1 - HB
0										2 - HRB
0										3 - HRC
0										4 - HV

Observações / Comments:
 OS CERTIFICADOS ORIGINAIS ENCONTRAM-SE EM NOSSO PODER, À SUA DISPOSIÇÃO. CERTIFICAMOS QUE OS PRODUTOS SUPRA ESTÃO APROVADOS, DE ACORDO COM AS ESPECIFICAÇÕES ACIMA MENCIONADAS, / THE ORIGINAL CERTIFICATES ARE FOUND AT OUR POWER, AT YOUR DISPOSAL. WE CERTIFY THAT THE SUITABLE PRODUCT(S) ARE APPROVED, IN ACCORDANCE WITH THE ABOVE SPECIFICATIONS.

São Paulo 17/05/2021 André G. Vieira - Depto Qualidade/ Quality Department

Aprovado
 17-05-21

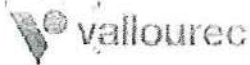

Vallourec Soluções Tubulares do Brasil S.A.
 Distrito Industrial - Jecaíba - MG - CEP: 35498-000 - Brasil

Certificado de Inspeção

(De acordo com DIN EN 10204.3.1)

Nº.: 0050771819 / 00

Folha: 17/5

Cliente: IMEFER-IND. E MERCANTIL DE FERRAGENS LTDA.

País: Brasil

Cod.Material: 704994

Num.Material Cliente (N.C.M): 020834

Pedido Usina: 585015 / 40

Pedido Cliente: P04-202024

Inspeção: Vallourec Soluções Tubulares do Brasil S.A.



PRODUTO: TUBO DE AÇO SEM COSTURA, LAMINADO À QUENTE, LAMINADO, PONTA CHANFRADA 37,5 GR. (Ângulo do Chanfro-Mínimo: 35,0 grau, Ângulo do Chanfro-Máximo: 40,0 grau), (Face do Chanfro - Mínimo: 0,80 mm, Face do Chanfro - Máximo: 2,40 mm)

DIMENSÕES: 219,10 mm X 8,18 mm GRAU DO AÇO: B # B # B

NORMAS: API SPEC 5L, 04.2018, 46TH EDITION - PSL 1

ATENDE TAMBÉM ÀS NORMAS: ASTM A106M - 19 # A # ASTM A 530M - 18 # ABNT NBR 6321, 06.2020

PROTEÇÃO SUPERFICIAL: EXTERNA: SEM PROTEÇÃO INTERNA: SEM PROTEÇÃO PROTEÇÃO DE PONTAS: CAPA DE POLIETILENO COM FURO

TOLERÂNCIAS: DIÂMETRO EXTERNO(CORPO TUBO): -0,80 mm / +1,60 mm PAREDE: -1,02 mm / +1,23 mm

TOLERÂNCIAS(PONTAS): DIÂMETRO EXTERNO: -0,80 mm / +1,10 mm

COMPRIMENTO: FAIXA 5000,00 mm - 2000,00 mm

MARCAÇÃO DE NORMA: PAINT STENCILED: MANUFACTURER API Spec 5L 0867 API MONOGRAM MONTH/YEAR ASTM A-106M / ABNT NBR 6321 219.1 8.18 B/B/B PSL1 SMILS HEAT NUMBER LENGTH S TESTED 11.0

MPANDE/END WEIGHT PIPE TALLY NO Segurança ABNT LOGO INMETRO 002488/2018 002483/2018 VSB LOGO

1112+2045
TB-095-21

Corrida	Amarrado	Pecas	Comprimento(m)	Peso (Kg)
190167	5001295231	1	6,95	292
	5001295232	1	6,94	290
	5001295233	1	6,95	312
	5001295234	1	6,95	294
	5001295235	1	6,95	305
	5001295236	1	6,94	295
	5001295240	1	6,94	296
	5001295241	1	6,95	296
	5001295242	1	6,84	287
	5001295243	1	6,85	293
	5001295244	1	6,84	298
	5001295245	1	6,85	291
	5001295249	1	6,86	292
	5001295250	1	6,85	291
	5001295252	1	6,84	302
	5001295304	1	6,94	291
	5001295305	1	6,94	290

Fornecedor: IMEFER
 NF: 104537 DATA: 09/08/21
 NR: TB-095-21 ITEM: 1112+2045
 Em conformidade com a ASME
 SA 106 Ed: 2019 Ad: -
 Inspetor Recebimento

CHAPA X B
 FABRICANTE VALLOUREC
 ESPECIF. A 106
 ESPEC. 8,18
 DIAM. 219,10
 COMPR. 41,09
 Nº DE VOLUME - 1000
 PRESSÃO DE TESTE

O CERTIFICADO ORIGINAL DO FORNECEDOR FABRICANTE ENCONTRA-SE EM NOSSOS ARQUIVOS PARA CONSULTA
 29 JUL 2021
 IMEFER Industrial e Mercantil de Ferragens Ltda

Corrida	Amarrado	Pecas	Comprimento(m)	Peso (Kg)
	5001295306	1	6,35	281
	5001295307	1	6,99	295
	5001295308	1	6,50	284
	5001295309	1	6,99	297
	5001295310	1	6,74	285
	5001295311	1	6,79	290
	5001295312	1	6,84	290
	5001295313	1	6,84	300
	5001295314	1	6,84	295
	5001295315	1	6,9	294
	5001295316	1	6,88	293
	5001295317	1	6,83	290
190170	5001295196	1	6,65	284
	5001295200	1	6,64	284
	5001295201	1	6,49	281
	5001295202	1	6,49	288
	5001295203	1	6,75	288
	5001295204	1	6,75	290
	5001295208	1	6,74	290
	5001295209	1	6,6	287
	5001295210	1	6,6	285
	5001295211	1	6,59	285
	5001295215	1	6,6	287
	5001295216	1	6,59	286
	5001295217	1	6,59	286
	5001295218	1	6,8	293
	5001295219	1	6,79	292
	5001295223	1	6,79	292
	5001295224	1	6,8	293
	5001295228	1	6,79	293
	5001295229	1	6,79	294
	5001295230	1	6,64	285



O CERTIFICADO ORIGINAL DO FORNECEDOR FABRICANTE ENCONTRA-SE EM NOSSOS ARQUIVOS PARA CONSULTA

29 JUL 2021

IMEFER Industrial e Mercantil de Ferragens Ltda

Corrida	Amarado	Peças	Comprimento(m)	Peso (Kgf)
	5001295251	1	6,44	282
	5001295253	1	6,83	294
	5001295267	1	6,65	285
	5001295268	1	6,65	285
	5001295274	1	6,43	277
	5001295275	1	6,43	283
	5001295280	1	6,74	290
	5001295281	1	6,74	290
	5001295282	1	6,75	290
	5001295286	1	6,56	285
	5001295287	1	6,56	285
	5001295288	1	6,33	274
	5001295294	1	6,33	279
	5001295295	1	6,65	287
	5001295296	1	6,56	284
	5001295297	1	6,67	288
	5001295298	1	6,79	291
	5001295299	1	6,79	291
	5001295300	1	6,79	292
	5001295301	1	6,67	287
	5001295302	1	6,67	288
	5001295303	1	6,66	289
	5001295318	1	6,48	287
	Total	72	484,38	2085,4



O CERTIFICADO ORIGINAL DO FORNECEDOR FABRICANTE ENCONTRA-SE EM NOSSOS ARQUIVOS PARA CONSULTA
29 JUL 2021
 INEFER Industrial e Mercantil de Ferragens Ltda

O PRODUTO FOI APROVADO NOS SEGUINTE TESTES/INSPEÇÕES: DIMENSIONAL # VISUAL # TESTE HIDROSTÁTICO: 11,0 MPA 5 S # MAGNETISMO RESIDUAL MÁXIMO: 30 GAUSS # TESTE ELETROMAGNÉTICO: L4(N12,5), LONG/TRANS, EXT #

Composição Química (%)

Ceq: C-Mn/6+(Cr-Mo-V)/5+(Ni-Cu)/15

EC3: Cr+Cu+Mo+Ni+V

Forno Elétrico a Arco, aço acalmado

		D1:										EC1: Nb+V			EC2: Nb+V+Ti						
		C	Mn	P	S	Si	Ni	Cr	Mo	Al	Cu	V	Nb	B	Ti	Ca	Ceq	EC1	EC2	EC3	
Análise de Corrida	Min		0,29			0,10															
	Max	0,250	1,35	0,030	0,0300		0,40	0,40	0,150		0,40	0,080		0,0010			0,43	0,06	0,15	1,00	
Análise de Produto	Min		0,29			0,10															
	Max	0,250	1,35	0,030	0,0300		0,40	0,40	0,150		0,40	0,080		0,0010			0,43	0,06	0,15	1,00	
Corrida	IPPN																				
190167	Ladle	0,190	1,03	0,010	0,0010	0,21	0,05	0,11	0,044	0,030	0,07	0,020	0,000	0,0000	0,003	0,0009	0,40	0,02	0,02	0,29	
	Check 1	305021	0,193	1,03	0,010	0,0015	0,21	0,05	0,11	0,040	0,030	0,07	0,021	0,000	0,0000	0,003	0,0011	0,41	0,02	0,02	0,29
	Check 2	105033	0,196	1,03	0,010	0,0013	0,21	0,05	0,11	0,040	0,031	0,07	0,022	0,000	0,0000	0,003	0,0012	0,41	0,02	0,02	0,29
190170	Ladle	0,190	1,02	0,009	0,0020	0,21	0,06	0,10	0,025	0,031	0,10	0,020	0,000	0,0000	0,002	0,0013	0,40	0,02	0,02	0,30	
	Check 1	510023	0,190	1,01	0,008	0,0019	0,21	0,06	0,10	0,020	0,031	0,09	0,021	0,000	0,0000	0,002	0,0016	0,40	0,02	0,02	0,29
	Check 2	507021	0,199	1,03	0,009	0,0020	0,22	0,06	0,10	0,030	0,033	0,10	0,022	0,001	0,0000	0,002	0,0019	0,41	0,02	0,02	0,31



Ceq: Carbono Equivalente; EC: Elementos Combinados;

Ensaio de Tração

Direção do Corpo Prova: Longitudinal

Temperatura: Ambiente

Corpo de Prova TIRA LARGURA 38,1 MM

Espessura da parede: 8,18 mm

Medida L0: L0=50MM

Método LE: Along. Total Sob Carga 0,50 %

		LE	RT	AL	
		(MPa)	(MPa)	(%)	
Especificado: Min		245	415	27	
Max					
Corrida	IPPN	Posição			
190167	305021	Pé	378	549	40
190170	510023	Cabeça	387	555	38

O CERTIFICADO ORIGINAL DO FORNECEDOR FABRICANTE ENCONTRA-SE EM NOSSOS ARQUIVOS PARA CONSULTA
 29 JUL 2021
 IMEIER Industrial e Mercantil de Ferragens Ltda

Observações:

NOTA FISCAL: 000361942



O CERTIFICADO ORIGINAL DO FORNECEDOR FABRICANTE ENCONTRA-SE EM NOSSOS ARQUIVOS PARA CONSULTA
29 JUL 2021
IZEPER Industrial e Mercantil de Ferragens Ltda

Certificamos que este material foi produzido e inspecionado de acordo com todas as exigências destas normas e especificações, e todos os resultados considerados satisfatórios. Este Certificado é processado por sistema informatizado e é válido sem assinatura.

DEPARTAMENTO DE CONTROLE DE QUALIDADE

FAX: (55-31) 2141 5365

e-mail: carlos.horta@ystubos.com

Carlos Eduardo Lima Horta
CARLOS EDUARDO LIMA HORTA
RESPONSÁVEL TÉCNICO

DATA
27.04.2021

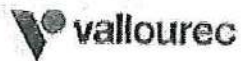

Vallourec Soluções Tubulares do Brasil S.A.
Usina Barreiro - Av. Olinto Meireles, 65
Barreiro de Baixo - CEP: 30640-010



Certificado de Inspeção

(De acordo com DIN EN 10204.3.1)

Nº.: 0050780243 / 01

Folha: 1 / 3

Cliente: IMEFER-IND. E MERCANTIL DE FERRAGENS LTDA.

País: Brasil

Cod. Material: 280419

Pedido Usina: 591372/60

Pedido Cliente: P05-202932

Num. Material Cliente (NCM): 021660



Inspeção: VALLOUREC SOL. TUBULARES BRASIL S.A. BARREIRO

DESCRIÇÃO DO PRODUTO: TUBO DE AÇO SEM COSTURA, LAMINADO À QUENTE, PONTA LISA, NORMALIZADO

DIMENSÕES: 48,30 mm X 5,10 mm GRAU DO AÇO: B # B # B

NORMAS: API SPEC 5L, 04.2018, 46TH EDITION - PSL 1

ATENDE TAMBÉM ÀS NORMAS: ASTM A 106M - 19 A ASTM A 530M - 18 # ABNT NBR 6321, 06.2020

ESPECIFICAÇÃO DE CLIENTE: VSB PP - 001/2020 - Rev 1 INT

PROTEÇÃO SUPERFICIAL: EXTERNA: SEM PROTEÇÃO PROTEÇÃO DE PONTAS: SEM PROTEÇÃO

TOLERÂNCIAS: DIÂMETRO EXTERNO(CORPO TUBO): -0,40 mm / +0,40 mm PAREDE: -0,64 mm / +0,78 mm

TOLERÂNCIAS(PONTAS): DIÂMETRO EXTERNO: -0,40 mm / +0,40 mm

COMPRIMENTO: FAIXA 5000,00 mm - 7000,00 mm

MARCAÇÃO DE NORMA: Estencilado no corpo do tubo: FABRICANTE API Spec 5L-0150.4 MONOGRAMA API MÊS/ANO ASTM A-106M / ABNT NBR 6321 48,30 X 5,10 B/B/B PSL1 SMLS NÚMERO DA CORRIDA 17000 KPA SCH 080 Segurança LOGOTIPO ABNT/INMETRO 002197/2018 002481/2018 LOGO VSB

1112+1865
TB-204-21

Corrida	Amarrado	Peças	Comprimento(m)	Peso (Kgf)
191377	PCA6215228	61	422,09	2340
Total		61	422,09	2340

O PRODUTO FOI APROVADO NOS SEGUINTES TESTES/INSPEÇÕES: DIMENSIONAL # VISUAL # TESTE DE DOBRAMENTO # TESTE HIDROSTÁTICO: 17000,0 KPA 5 S #

JOHNSON CONTROLS

Fornecedor: IMEFER

Nº: 105176 DATA: 30/08/21

NR: TB-104-21 ITEM: 1112+1865

Em conformidade com a ASME

SA 106 Ed: 2018 Ad: -

Assinatura: _____

JOHNSON CONTROLS

CHAPA TUBO

FABRICANTE VALLOUREC

ESPECIF. A 106 B

ESPEC. 5,10

DIAM. 48,30 SCH. 80/XS

COMPRIM. 20,55 CORRIDA 191377

Nº DE VOLUME -

PRESSÃO DE TESTE 17000

O CERTIFICADO ORIGINAL DO FORNECEDOR FABRICANTE ENCONTRA-SE EM Nossos ARQUIVOS PARA CONSULTA

19 AGO 2021

IMEFER Industrial e Mercantil de Ferragens Ltda.

Composição Química (%)

Processo: Forno básico a oxigênio, aço acalmado

Ceq: C+Mn/6+(Cr+Mo+V)/5+(Ni+Cu)/15		EC1: Nb + V				EC2: Nb + V + Ti							EC3: Cr + Cu + Mo + Ni + V							
		C	Mn	P	S	Si	Ni	Cr	Mo	Al	Cu	V	Nb	B	Ti	Ca	Ceq	EC1	EC2	EC3
Análise de Corrida	Min		0,29			0,10														
	Max	0,220	1,15	0,025	0,0250		0,40	0,40	0,150		0,40	0,080		0,0010	0,040		0,43	0,06	0,15	1,00
Análise de Produto	Min		0,29			0,10														
	Max	0,220	1,15	0,025	0,0250		0,40	0,40	0,150		0,40	0,080		0,0010	0,040		0,43	0,06	0,15	1,00
Corrida	Lote Controle																			
191377	030003599403	0,186	1,07	0,012	0,0034	0,30	0,03	0,07	0,018	0,030	0,07	0,003	0,000	0,0002	0,004	0,0020	0,39	0,00	0,01	0,19
	Check 1	0,176	1,07	0,011	0,0032	0,31	0,03	0,08	0,018	0,032	0,07	0,003	0,002	0,0000	0,004	0,0025	0,38	0,00	0,01	0,20
	Check 2	0,176	1,07	0,012	0,0026	0,30	0,03	0,07	0,017	0,031	0,07	0,001	0,002	0,0000	0,004	0,0014	0,38	0,00	0,01	0,19

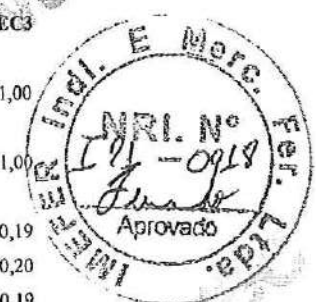

Ceq: Carbono Equivalente; EC: Elementos Combinados;

Ensaio de Tração

Direção do Corpo Prova: Longitudinal

Temperatura: Ambiente

Espessura da parede: 5,10 mm

Medida L0: L0=2"

Método LE: Along. Total Sob Carga 0,50 %

		Corpo de Prova			Área	LE	RT	AL
					(MM ²)	(MPA)	(MPA)	(%)
Especificado: Min						245	415	22,0
Max								
Corrida	Lote Controle	TIRA LARGURA 12,7 MM			70,5	368	534	33,0
191377	030003599403							

LE-Límite de Escoamento; RT-Resistência a Tração; AL-Alongamento;

Ensaio de Dureza

Escala: HV10

		Especificado: Min
		Max 248,0
Corrida	Lote Controle	
191377	030003599403	156,0

O CERTIFICADO ORIGINAL DO FORNECEDOR FABRICANTE ENCONTRA-SE EM NOSSOS ARQUIVOS PARA CONSULTA
19 AGO 2021
IMEFER Indústria e Comércio de Ferragens Ltda

Observações:

NOTA FISCAL: 000263394

Este certificado cancela e substitui o0050780243/00, devido a(os), seguinte(s) motivo(s):

revisão conforme not fiscal



O CERTIFICADO ORIGINAL DO FORNECEDOR FABRICANTE ENCONTRA-SE EM NOSSOS ARQUIVOS PARA CONSULTA
19 AGO 2021
IMEFER Industrial e Mercantil de Ferragens Ltda

certificamos que este material foi produzido e inspecionado de acordo com todas as exigências destas normas e especificações, e todos os resultados considerados satisfatórios. Este Certificado processado por sistema informatizado e é válido sem assinatura.

DEPARTAMENTO DE CONTROLE DE QUALIDADE
FAX: (55-31) 2141-5365
e-mail: carlos.horta@vstubos.com

CARLOS EDUARDO LIMA HORTA
RESPONSÁVEL TÉCNICO

DATA
15.07.2021



4) DOCUMENTOS DE SOLDA
WELDING RECORDS

MAPA DE SOLDAGEM
(WELD MAP)

SEPARADOR DE OLEO HOS 36
(OIL SEPARATOR)

Nº PEDIDO (Nº ORDER)	32107D026	Nº SERIE (SERIAL NUMBER)	367258	REV.0
DESENHO (DRAWING)	548E0406G31BR	REV.8	DATA (DATE)	JULY 18, 2021

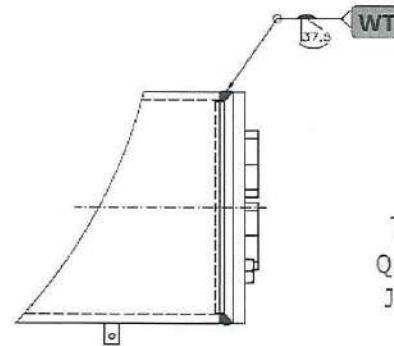
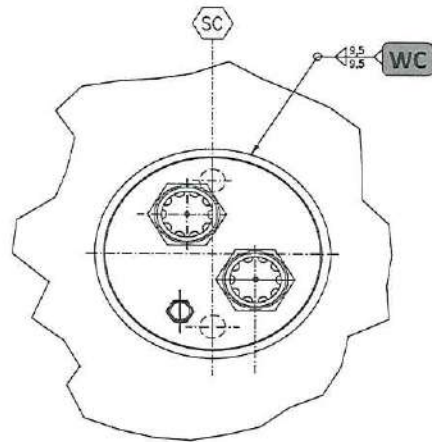
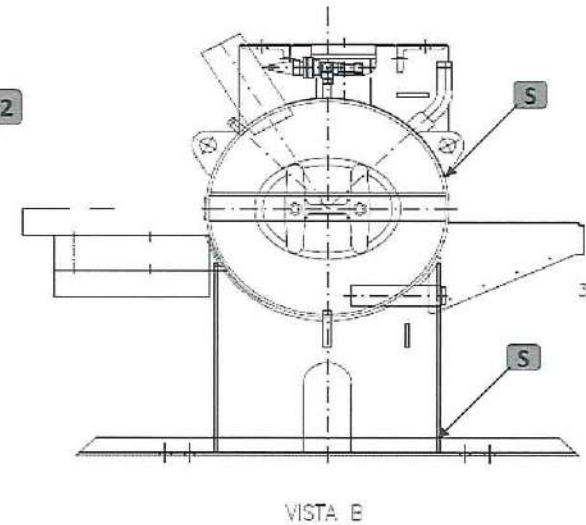
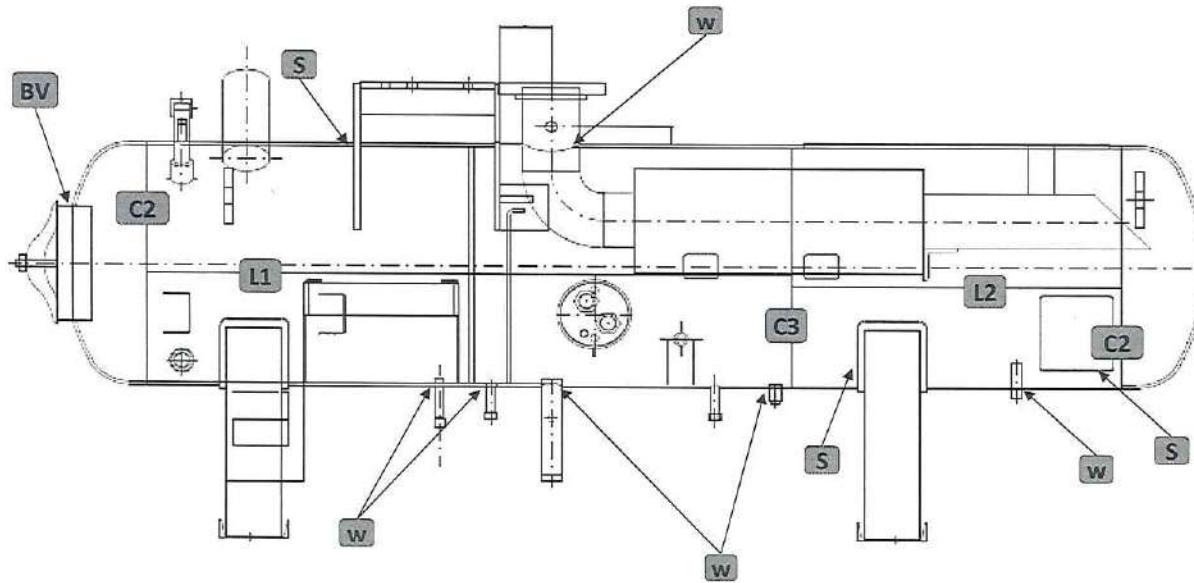

Tiago Fur
Quality specialist
Johnson Controls

30/4/18/21

JUNTA TÍPICA TYPICAL JOINTS	TIPO (TYPE)	PROCESSO (WELD PROCESS)	EPS (WPS)	SINETE (STAMP)
W	CONEXÃO TUBULAR x CASCO	GTAW FCAW	J003/11 Rv.5 J041/19 Rv.1	FQ
BV	BOCA DE VISITA X CASCO	FCAW	J041/19 Rv.1	FQ
L1/L2	SOLDA LONGITUDINAL	GMAW+ SAW	SB017/00 Rv.3	MV
C1/C2/C3	SOLDA CIRCUNFERENCIAL	GMAW+ SAW	SB017/00 Rv.3	MV
WC	CONEXÃO CASCO	GTAW	J003/11 Rv.5	FQ
B2	BATOQUE	FCAW	J041/19 Rv.1	FQ
S	SELAS E SUPORTES	FCAW	J041/19 Rv.1	FQ
WT	TUBO TAMPA	GTAW	J003/11 Rv.5	FQ

MAPA DE SOLDAGEM
(WELD MAP)

FILTRO DE OLEO FO 43DN73
(OIL FILTER)

Nº PEDIDO (Nº ORDER)	32107D026	Nº SERIE (SERIAL NUMBER)	391216	REV.0
DESENHO (DRAWING)	553E0014BR	REV.0	DATA (DATE)	JULY 18, 2021

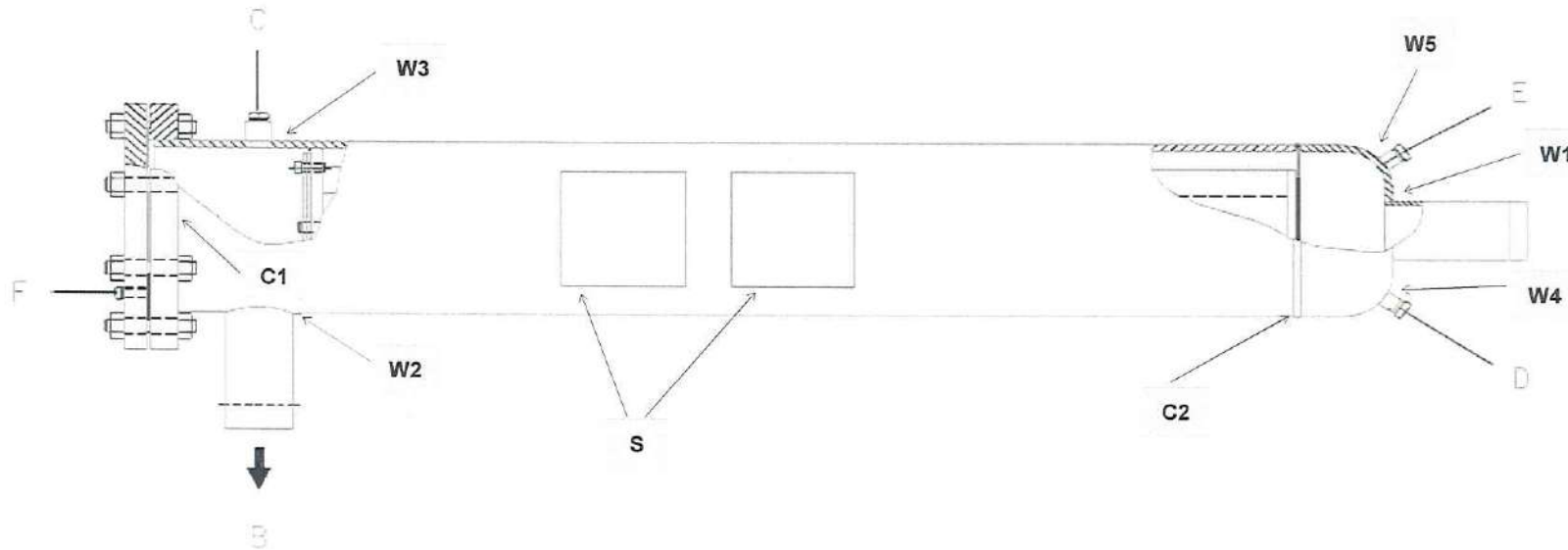

JUNTA TÍPICA TYPICAL JOINTS	TIPO (TYPE)	PROCESSO (WELD PROCESS)	EPS (WPS)	SINETE (STAMP)
W	CONEXÃO TUBULAR x CASCO	GTAW	J003/11 Rv.4	FQ
C1	FLANGE x CASCO	GMAW	J012/11 Rv.4	FQ
C2	FUNDO x CASCO	GMAW	J012/11 Rv.4	FQ
S	SUPORTE	GTAW	J003/11 Rv.4	FQ

Tiago Fu
Quality specialist
Johnson Controls

MAPA DE SOLDAGEM
(WELD MAP)

FILTRO DE OLEO FO 43DN73
(OIL FILTER)

Nº PEDIDO (Nº ORDER)	32107D026	Nº SERIE (SERIAL NUMBER)	391217	REV.0
DESENHO (DRAWING)	553E0014BR	REV.0	DATA (DATE)	JULY 18, 2021

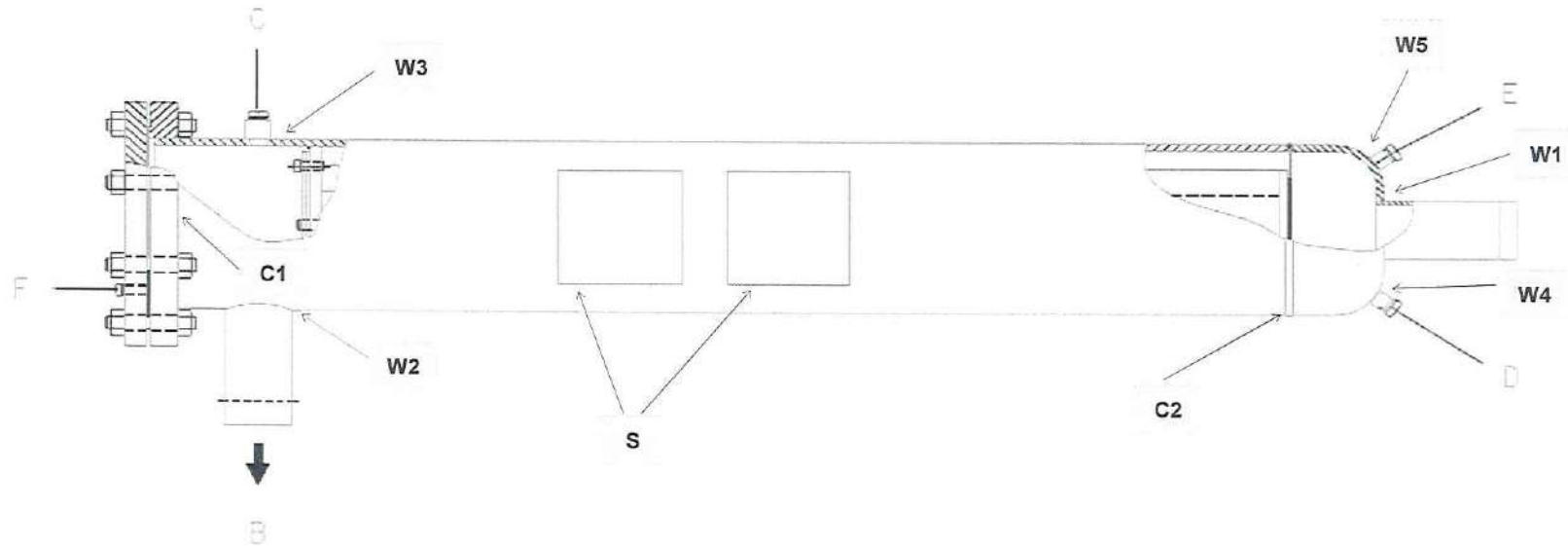

Tiago Fui
 Quality specialist
 Johnson Controls
 July 18, 21

JUNTA TÍPICA (TYPICAL JOINTS)	TIPO (TYPE)	PROCESSO (WELD PROCESS)	EPS (WPS)	SINETE (STAMP)
W	CONEXÃO TUBULAR x CASCO	GTAW	J003/11 Rv.4	FQ
C1	FLANGE x CASCO	GMAW	J012/11 Rv.4	FQ
C2	FUNDO x CASCO	GMAW	J012/11 Rv.4	FQ
S	SUPORTE	GTAW	J003/11 Rv.4	FQ

NORMA APLICAVEL (APPLICABLE CODE): ASME SEÇÃO IX, ED. 2019 / COMPLEMENTAR (OTHER): -----
 TESTES REQUERIDOS (REQUIRED TESTS): VISUAL, TRAÇÃO E DOBRAMENTO (VISUAL EXAMINATION, TENSION AND BEND TESTS)

PROCESSO DE SOLDAGEM (WELDING PROCESS): **TIG (GTAW)**
 TIPO (TYPE): [] AUTOMÁTICO (AUTOMATIC) [] SEMI-AUTOMÁTICO (SEMI-AUTO) [X] MANUAL (MANUAL) /
 RQR SUPORTE Nº (SUPPORTING PQR Nº): Y 26/04; J 003/11 / DATA (DATE): 23/02/11

QW 402 JUNTAS (JOINTS)

TIPO DE CHANFRO (TYPE OF GROOVE): CONFORME DESENHO DE FABRICAÇÃO (ACCORDING TO FABRICATION DRAWINGS)
 COBRE - JUNTA (BACKING): NÃO USAR (NOT USE) MATERIAL DO COBRE-JUNTA (BACKING MATERIAL): NÃO USADO (N.U.)
 RETENTORES (RETAINERS): NÃO USAR (N.U.) ABERTURA DE RAIZ (ROOT SPACING): VER DESENHOS (SEE DRAWINGS)
 DETALHES DAS JUNTAS (JOINT DESIGN): TOPO E ÂNGULO (BUTT AND FILLET JOINT)

METODO DE PREPARAÇÃO (PREPARATION): GUILHOTINA / ESMERILHAMENTO (GUILLOTINE CUTTER/GRINDING)
 USINAGEM (MACHINING)
 OXICORTE / ESMERILHAMENTO (FLAME CUT/GRINDING)

OUTROS (OTHERS): PARA OUTRO DETALHES DE JUNTAS, VER DESENHOS (SEE DRAWINGS FOR OTHERS JOINTS DETAILS)

QW 403 METAL BASE (BASE METALS) /

P Nº (P Nr) **1** GR. (GROUP) **1/2** x P Nº (P Nr) **1** GR. (GROUP) **1/2** /
 ESPECIF. (SPECIFIC.) TIPO E GRAU (TYPE AND GRADE): --
 COM (TO)
 ESPECIF. (SPECIFIC.) TIPO E GRAU (TYPE AND GRADE): --

FAIXA DE ESPESSURAS (THICKNESS RANGE)

METAL DE BASE (BASE METAL):
 CHANFRO (GROOVE): **1,5 - 17,1mm**
 ÂNGULO (FILLET): **TODAS (ALL)**

FAIXA DE DIÂMETROS (PIPE DIAMETER RANGE):
 CHANFRO (GROOVE): **TODOS (ALL)**
 ÂNGULO (FILLET): **TODOS (ALL)**

QW 404 METAL DE ADIÇÃO (FILLER METAL)

ESPECIFICAÇÃO (SPECIFICATION) SFA: **5.18** / F Nº: **6** /
 CLASSE (CLASS.) AWS: **ER 70S6** / A Nº: **1** /
 DIÂMETROS (DIAMETERS): **1,6/ 2,5/ 3,2 mm** /
 METAL DE ADIÇÃO (FILLER METAL): **COM (WITH)** /
 FORMA DO PRODUTO (FILLER METAL PROD. FORM): **SÓLIDO (SOLID)** /
 ELEMENTOS DE LIGA (ALLOY ELEMENTS): **NÃO USADO (N.U.)** /
 FAIXA DE ESPES. METAL DEPOSITADO (WELD METAL THICK. RANGE):
 CHANFRO (GROOVE): **17,1 mm Max.** /
 ÂNGULO (FILLET): **TODAS (ALL)** /
 MARCA COMERCIAL (TRADE MARK): **ESTOQUE (STOCK)** /
 INSERTO CONSUMÍVEL (INSERT): **Não Usado (Not Used)** /
 FLUXO (FLUX): **NÃO USAR (NOT USE)** /

QW 405 POSIÇÃO DE SOLDAGEM (POSITION)

POSIÇÃO DO CHANFRO (GROOVE OF POSITION): **TODAS (ALL)** /
 PROGR. DE SOLDAGEM (WELD. PROGRESSION): **ASCENDENTE (UPHILL)** /
 POSIÇÃO EM ÂNGULO (POSITION OF FILLET): **TODAS (ALL)** /

QW 407 TRAT. TÉRMICO (POSTWELD HEAT TREATMENT)

TIPO (TYPE): **Não Usado (Not Used)** /
 GRADIENTE AQUECIMENTO. (HEATING TAX.): **Não Usado (Not Used)**
 TEMPERATURA (TEMPERATURE RANGE): **Não Usado (Not Used)**
 TEMPO DE PERMANENCIA (TIME RANGE): **Não Usado (Not Used)**
 GRADIENTE RESFRIAMENTO (COOLING TAX.): **Não Usado (Not Used)**

QW 406 PRÉ-AQUECIMENTO (PRE HEAT)

TEMPERAT. PRÉ-AQUEC. MIN. (PRE HEAT TEMP. MIN.): **t ≥ 25 mm = 18° C** /
 TEMP. INTERPASSES MÁX. (INTER. TEMP. MAX.): **250° C**
 PÓS AQUECIMENTO (PRE HEAT MAINTENANCE): **Não Usado (N.U.)** /

QW 408 GÁS (GAS)

GÁS DE PROTEÇÃO (SHIELDING GAS): **Ar** /
 COMPOSIÇÃO (COMPOSITION): **N.A. (Not Applicable)** /
 VAZÃO (FLOW RATE): **10 - 15 l/min. (liters/ min.)** /
 GAS DE PURGA (TRAINING GAS): **Não Usado (NOT USED)** /
 PROTEÇÃO NA RAIZ (BACKING GAS): **Não usado (N.U.)** /

QW 409 CARACTERÍSTICAS ELÉTRICAS (ELECTRICAL CHARACTERISTICS)

CORRENTE (CURRENT): **CC (CONTINUOUS)** / POLARIDADE (POLARITY): **DIRETA (-) (DIRECT)** /
 FAIXA DE CORRENTE (AMPER. RANGE): **80 - 180 A** / FAIXA DE TENSÃO (VOLT RANGE): **8 - 15 V** /
 MODO DE TRANSFERENCIA (TRANSFER MODE): **NÃO APLICAVEL (Not Applicable)** CORRENTE PULSADA (PULSING CURRENT): **NÃO USAR (N.U.)**
 VELOCIDADE DO ARAME (FEED SPEED RANGE): **NÃO APLICAVEL (Not Applicable)**
 ELETRODO DE TUNGSTENIO - TIPO E Ø (TUNGSTEN ELECTRODE - Ø AND TYPE): **EWTh 2% Ø 2,4 / 3,2 mm** /

CAMADAS (LAYERS)	PROCESSO (PROCESS)	METAL DE ADIÇÃO (FILLER METAL)		CORRENTE (A) (CURRENT)		TENSÃO (V) (VOLT RANGE)	VELOC. AVANÇO (TRAVEL SPEED) cm / min.	OBS.
		CLASS	DIAM.	POLA.	AMPE			
INICIAL / OUTRAS (INITIAL & OTHERS)	TIG (GTAW)	ER 70 S6	1,6 mm 2,4 mm 3,2 mm	CC -	80-180	8-15	-----	-----

QW 410 TÉCNICA DE SOLDAGEM (TECHNIQUE)

GOIVAGEM (METHOD BACK GOUGE): **Não Usar (N.U.)** / PROCESSO TÉRMICO DE PREPARAÇÃO (THERMAL PROCESS): **Não Usado (N.U.)** /
 LIMPEZA INICIAL / INTERPASSES / FINAL (INITIAL, INTERPASS AND ENDED CLEANING): **Escovar / Esmerilhar (TO BRUSH / TO GRIND)** /
 DIÂM. BOCAL DO GÁS (GAS CUP SIZE): **6 / 7 / 8 mm** / DISTANCIA BICO DE CONTATO (STICKOUT): **Não Usado (Not Used)** /
 TIPO DE CORDÃO (TYPE OF BEAD): **FILETADO/OSCILADO (WEAVE / ISTRINGER)** ELETRODOS (ELECTRODES): **Simples (SINGLE)** /
 ESPAÇAMENTO ENTRE ELETRODOS (ELECTRODE SPACING): **Não Aplicave (N.A.)** /
 OSCILAÇÃO MAX. (OSCILATION): **NÃO USADO (N.U.)** / MUDANÇA CAMARA FECHADA / ABERTA (CLOSED TO OUT CHAMBER): **N.A. (N.A.)** /
 PASSES (PASS): **MULTI PLOS/SIMPLES (MULTPASS / SINGLE)** / MARTELAMENTO (PEENING): **Não Usar (Not Use)** /
 RESFRIAMENTO PÓS SOLDAGEM (POSTWELDING COOLING): **AO AR CALMO (AIR)** /
 OUTROS (OTHERS): **AS SUPERFÍCIES A SEREM SOLDADAS DEVEM ESTAR ISENTAS DE ÓLEO, GRAXA, CAREPAS, ETC.**
 (THE JOINTS CAN BE THE SURFACE CLEAN, FREE FROM THE OIL, GREASE AND CRAP.)

LISTA DE REVISÕES (REVISION):

Rev. 1	DATA (DATE): 08/05/2014	- Correção Editorial (Editorial Correction)
Rev. 2	DATA (DATE): 25/08/2016	- Correção Editorial (Editorial Correction)
Rev. 3	DATA (DATE): 13/03/2017	- Correção Editorial (Editorial Correction)
Rev. 4	DATA (DATE): 04/04/2017	- Correção Editorial (Editorial Correction)
Rev. 5	DATA (DATE): 09/11/2020	- Correção Editorial (Editorial Correction)

DATA (DATE): 09/11/2020

Thiago Furlan
 Quality specialist
 Johnson Controls
 JOHNSON CONTROLS BE DO BRASIL



FOLHA (PAGE) 01 / 2

REGISTRO DE QUALIFICAÇÃO DE PROCEDIMENTO DE SOLDAGEM
(WELDING PROCEDURE QUALIFICATION RECORD)

DATA (DATE) 05 / 10 / 2004

RQPS (PQR) Y 26 / 04

EPS (WPS) No.: SB 003 / 94

PROCESSO DE SOLDAGEM (WELDING PROCESS) : GTAW

TIPO (TYPE) : MANUAL

JUNTAS (JOINTS) QW 402

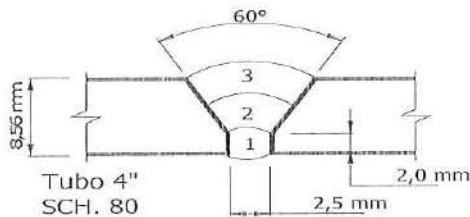

METAL BASE (BASE METAL.) QW 403

ESPECIFICAÇÃO (SPECIFICATION) : SA 106 GR.B x SA 106 GR.B
P No. (P No.) 1 x 1 P No (P No.)
ESPESSURA DO CP (THICKNESS OF TC) : 8,56 mm
DIÂMETRO DO CP (DIAMETER OF TC) : TODOS
OUTROS (OTHERS) : CERTIFICADO VALLOUREC & MANNESMANN
0050049015 - TB 119 / 04

METAL DE ADIÇÃO (FILLER METAL) QW 404

POSIÇÃO DE SOLDAGEM (POSITION) QW 405

RAIZ (ROOT)	DEMAIS (OTHERS)
------------------	----------------------

POSIÇÃO DO CHANFRO (POSITION) : 6G
PROGRESSÃO (WELD PROGRESSION) ASCENDENTE
OUTROS (OTHERS) : -----

DIÂMETRO (DIAMETER)

2, 4 / 3, 2 mm

A No (A No.)

1

F No (F No.)

6

PRÉ AQUECIMENTO (PRE HEAT) QW 406

ESPECIFICAÇÃO (SPECIFICATION)

SFA 5.18

CLASSIFICAÇÃO (CLASSIFICATION)

ER 70 S3

TEMP. PRÉ AQUECIMENTO (PRE HEAT TEMP.) : 21°C

TEMP. INTERPASSES (INTERPASS TEMP.) : 150°C

FAIXA DE ESPESSURAS (THICKNESS RANGE) < 17,1 mm

OUTROS (OTHERS) : CERTIFICADOS DE QUALIDADE 124819 / 20

GERDAU

OUTROS (OTHERS) : CONTROLE POR TERMÔMETRO DE CONTATO

TRATAMENTO TERMICO (POST WELD HEAT TREAT.) QW 407

GAS (GAS) QW 408

TEMPERATURA (TEMPERATURE RANGE) -----

TEMPO DE PERMANENCIA (TIME RANGE) -----

OUTROS (OTHERS) -----

TIPO (TYPE) : ARGONIO

COMPOSIÇÃO (COMPOSITION) : 99,9%

VAZÃO (FLOW RATE) : 8 L / MIN.

OUTROS (OTHERS) : -----

CARACTERISTICAS ELETRICAS (ELECTRICAL CHARACTERISTICS) QW 409

CORRENTE (CURRENT) : CONTINUA

AMPERAGEM : 95 / 130

POLARIDADE (POLARITY) : DIRETA

VOLT : 12 / 14

OUTROS (OTHERS) -----

TÉCNICA (TECHNIQUE) QW 410

DEPOSIÇÃO (DEPOSITION) : FILETE / OSCILADA

PASSES (PASS) : MULTIPLOS

ELETRODO (ELECTRODES) : -----

OSCILAÇÃO : ATE 3 X DIAMETRO DA VARETA

OUTROS (OTHERS) : LIMPEZA INICIAL E ENTREPASSES COM ESMERILHADEIRA (DISCO COM ALMA DE NYLON E ESCOVA DE AÇO)

PASSES (PASS) No (No.)	DIAM (mm)	CORRENTE AMPS	TENSÃO VOLTS	VEL. TRABALHO (SPEED TRAVEL) CM / MIN	OUTROS (OTHERS)
RAIZ	2, 4	98	12	7	-----
2°	3, 2	125	13,5	7,2	-----
3°	3, 2	130	13,7	7,4	-----



RQPNo.(PQRNr.) Y 26 / 04
FOLHA (PAGE) 02 / 02

QW 150 ENSAIOS DE TRAÇÃO (TENSILE TEST)

CP No. (SPECIMEN Nr.)	DIMENSÕES (DIMENSIONS) mm	AREA DA SECCÃO (AREA) mm ²	CARGA TOTAL DE RUPTURA (ULTIMATE TOTAL LOAD) N	TENSÃO DE RUPTURA (ULTIMATE UNIT STRESS) N/mm ²	LOCAL DA FRATURA (FAILURE LOCATION)
T1	19,18 X 8,30	159 , 19	80391	505	FORA DA SOLDA
T2	19,17 X 8,00	153 , 36	77750	505	FORA DA SOLDA

QW 170 ENSAIOS DE IMPACTO (IMPACT TEST)

TIPO E FIGURA No. (TYPE AND FIGURE Nr.)	RESULTADOS (RESULTS)
DOBRAMENTO LATERAL 1 QW462.2	NÃO APRESENTOU DESCONTINUIDADES
DOBRAMENTO LATERAL 2 QW462.2	NÃO APRESENTOU DESCONTINUIDADES
DOBRAMENTO LATERAL 3 QW462.2	NÃO APRESENTOU DESCONTINUIDADES
DOBRAMENTO LATERAL 4 QW462.2	NÃO APRESENTOU DESCONTINUIDADES

QW 170 ENSAIOS DE IMPACTO (IMPACT TEST)

TIPO : ----- (TYPE)		TEMPERATURA : ----- (TEMPERATURE)		DIMENSÃO DO CP : ----- (SPECIMEN DIMENSIONS)	
CP No (SPECIMEN Nr.)	LOCAL DO ENTALHE (NOTCH LOCATION)	ENERGIA ABSORVIDA (IMPACT VALUES) J		EXPANSÃO LATERAL (LATERAL EXPANSION) mm	QUEDA DE PESO (DROP WEIGHT) RESULTADOS (RESULTS)
		INDIVIDUAL (INDIVID.)	MEDIA (AVERAGE)		
-----	-----	-----	-----	-----	-----
-----	-----	-----	-----	-----	-----
-----	-----	-----	-----	-----	-----
-----	-----	-----	-----	-----	-----
-----	-----	-----	-----	-----	-----
-----	-----	-----	-----	-----	-----

OBS. (OBSERVATIONS) REGISTRO DE QUALIFICAÇÃO " APROVADO " CONFORME CERTIFICADO DE ENSAIO 04102077MCSP
TORK CONTROLE TECNOLOGICO DE MATERIAIS LTDA

NOME DO SOLDADOR (WELDERS NAME) : FRANCISCO IVANILSON P. RODRIGUES
CARTEIRA PROF. No. (WORK PERMIT. Nr.) : SERIE SINEIE (STAMP) AE

CERTIFICAMOS QUE AS INFORMAÇÕES DESTE REGISTRO SÃO CORRETAS E QUE AMOSTRA SOLDADA FOI PREPARADA , EXECUTADA E ENSAIADA CONFORME AS EXIGÊNCIAS DO CÓDIGO ASME SEÇÃO IX / 01.
WE CERTIFY THAT STATEMENTS IN THIS RECORD ARE CORRECT AND THAT THE TEST WELDS WERE PREPARED, WELDED AND TESTED IN ACCORDANCE WITH REQUIREMENTS OF ASME CODE SECTION IX / 01 .

Tiago Furlan
Quality Specialist
Johnson Controls
CONTROLE DE QUALIDADE

SÃO PAULO : 05 / 10 / 04

REGISTRO DE QUALIFICAÇÃO DE PROCEDIMENTO DE SOLDAGEM
 (WELDING PROCEDURE QUALIFICATION RECORD)

RQPS (WPQR) Nº.: J 003 / 11
 PROCESSO DE SOLDAGEM (WELDING PROCESS) : GTAW

EPS (WPS) Nº.: J 003 / 11
 TIPO (TYPE) : MANUAL

JUNTAS (JOINTS) QW 402

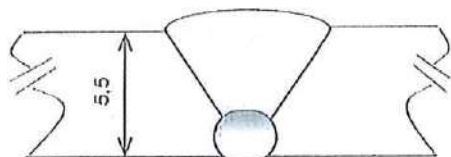

METAL BASE (BASE METAL) QW 403

ESPECIFICAÇÃO (SPECIFICATION) : SA 106 Gr.B x SA 106 Gr.B
 P Nº. (P Nr.) : 1 Gr. 2 x 1 Gr. 2
 ESPESSURA DO CP (THICKNESS OF TC) : 5,5 mm
 DIÂMETRO DO CP (DIAMETER OF TC) : -----
 OUTROS (OTHERS) : CERTIFICADO V&M 0050448579

METAL DE ADIÇÃO (FILLER METAL) QW 404

DIÂMETRO (DIAMETER)
 A Nº (A Nr.)
 F Nº (F Nr.)

1º / 2º	DEMAIS (OTHERS)
3,2 mm	3,2 mm
ER 70S6	ER 70S6
6	6
SFA 5.18	SFA 5.18
ER 70 S6	ER 70 S6

ESPECIFICAÇÃO (SPECIFICATION)
 CLASSIFICAÇÃO (CLASSIFICATION)

METAL DEPOSITADO (WELD METAL) 5,5 mm (GTAW)
 FORMA DO PRODUTO (FILLER METAL PROD. FORM) : SOLIDO (SOLID)
 ADIÇÃO DE METAL DE SOLDA (FILLER METAL) : COM (WITH)
 OUTROS (OTHERS) : CERTIFICADO BELGO 69737 Ø 3,2 mm ;

POSIÇÃO DE SOLDAGEM (POSITION) QW 405

POSIÇÃO DO CHANFRO (POSITION) : 6G
 PROGRESSÃO (WELD PROGRESSION) : ASCENDENTE (UPHILL)
 OUTROS (OTHERS) : -----

PRÉ AQUECIMENTO (PRE HEAT) QW 406

TEMPERATURA PRÉ AQUECIMENTO (PRE HEAT TEMP.) : 18 °C
 TEMPERATURA INTERPASSES (INTERPASS TEMP.) : 250 °C
 OUTROS (OTHERS) : TERMOMETRO DE CONTATO

TRATAMENTO TÉRM. (POST WELD HEAT TRATAMENT) QW 407
 (NOT USED)

TEMPERATURA (TEMPERATURE RANGE) : N.A.
 TEMPO DE PERMANÊNCIA (TIME RANGE) : N.A.
 OUTROS (OTHERS) : -----

GAS (GAS) QW 408

TIPO (SHIELDING GAS) : ARGONIO
 COMPOSIÇÃO (COMPOSITION) : N.A.
 VAZÃO (FLOW RATE) : 12 l / min.
 GAS DE PURGA (BACKING GAS) : NÃO USADO (NOT USED)
 OUTROS (OTHERS) : TRAILLING GAS: N.U.

GARACT. ELÉTRICAS (ELECTRICAL CHARACTERISTICS) QW 409

CORRENTE (CURRENT) : CONTINUA AMPERAGEM : 110 / 145 A
 POLARIDADE (POLARITY) : DIRETA VOLT : 13 / 14 V
 MODO DE TRANSFER. (MODE OF METAL TRANSFER) : N. A.
 OUTROS (OTHERS) : -----

TÉCNICA (TECHNIQUE) QW 410

PASSE (PASS) : MULTIPLOS
 DEPOSIÇÃO (DEPOSITION) : RETILINEA
 OSCILAÇÃO (OSCILATION) : -----
 MUDANÇA CAMARA FECHADA P/ ABERTA : N.A. (NOT APPLICABLE)
 (CLOSED TO OUT CHAMBER)
 PROC. TERMICO DE PREPARAÇÃO (THERMAL PROCESS) : N.A. (N.A.)

PASSES (PASS) Nº (Nr.)	DIAM. (mm)	CORRENTE (CURRENT) AMPS	TENSÃO VOLTS	VELOCIDADE DE TRABALHO (SPEED TRAVEL) cm / min.	OUTROS (OTHERS)
RAIZ	3,25	125	13	----	----
2º	3,25	130	14	----	----
3º	3,25	145	14	----	----
4º	3,25	110	13	----	----
5º	3,25	110	13	----	----



QW 150 ENSAIOS DE TRAÇÃO (TENSILE TEST)

CP Nº (SPECIMEN Nr.)	DIMENSÕES (DIMENSIONS) mm	AREA DA SECÇÃO (AREA) mm ²	CARGA TOTAL DE RUPTURA (ULTIMATE TOTAL LOAD) kgf	TENSÃO RUPTURA (ULTIMATE UNIT STRESS) MPA	LOCAL DA FRATURA (FAILURE LOCATION)
T1	19,0 x 5,69	106,21	6200	570	FORA DA SOLDA
T2	18,96 x 5,78	109,59	6000	535	FORA DA SOLDA

QW 160 ENSAIO DE DOBRAMENTO (BEND TEST)

TIPO E FIGURA Nº (TYPE AND FIGURE Nr.)	DIMENSÕES mm	RESULTADOS (RESULTS)
DOB. FACE 1 QW462.2	19,0 x 5,5	APRESENTOU DESCONTINUIDADE NA SOLDA < 2,4 mm
DOB. RAIZ 1 QW462.2	19,0 x 5,5	NÃO APRESENTOU DESCONTINUIDADES
DOB. FACE 2 QW462.2	19,0 x 5,5	NÃO APRESENTOU DESCONTINUIDADES
DOB. RAIZ 2 QW462.2	19,0 x 5,5	NÃO APRESENTOU DESCONTINUIDADES

QW 170 ENSAIOS DE IMPACTO (IMPACT TEST)

TIPO : ----- (TYPE)		TEMPERATURA : ----- (TEMPERATURE)		DIMENSÃO DO CP : ----- (SPECIMEN DIMENSIONS)	
CP Nº. (SPECIMEN Nr.)	LOCAL DO ENTALHE (NOTCH LOCATION)	ENERGIA ABSORVIDA (Joules) (IMPACT VALUES)		EXPANSÃO LATERAL (LATERAL EXPANSION) mm	QUEDA DE PESO (DROP WEIGHT) RESULTADOS (RESULTS)
		INDIVIDUAL (INDIVID.)	MEDIA (AVERAGE)		
-----	-----	-----	-----	-----	-----
-----	-----	-----	-----	-----	-----
-----	-----	-----	-----	-----	-----
-----	-----	-----	-----	-----	-----
-----	-----	-----	-----	-----	-----
-----	-----	-----	-----	-----	-----
-----	-----	-----	-----	-----	-----
-----	-----	-----	-----	-----	-----
-----	-----	-----	-----	-----	-----

OBS. (OBSERVATIONS) 1 - REGISTRO DE QUALIFICAÇÃO " APROVADO " CONFORME CERTIFICADO DE ENSAIOS DO LABORATÓRIO TORIK 11035841MCSP

2 - ENSAIO ADICIONAL DUREZA " HV 10 " RESULTADO FACE 163;176;173;188;199;201;181;172;180;168;162;165;169;169;169
RELATÓRIO 11035841MCSP FL. 2 / 2

NOME DO SOLDADOR (WELDERS NAME) : JOSÉ CARDOSO DA SILVA

CARTEIRA PROF. Nº (WORK PERMIT. Nr.) : ----- SÉRIE --- SINETE (STAMP) E2

CERTIFICAMOS QUE AS INFORMAÇÕES DESTE REGISTRO SÃO CORRETAS E QUE AMOSTRA SOLDADA FOI PREPARADA , EXECUTADA E ENSAIADA CONFORME AS EXIGÊNCIAS DO CODIGO ASME SEÇÃO IX / 11.
WE CERTIFY THAT STATEMENTS IN THIS RECORD ARE CORRECT AND THAT THE TEST WELDS WERE PREPARED , WELDED AND TESTED IN ACCORDANCE WITH REQUIREMENTS OF ASME CODE SECTION IX / 11 .

SÃO PAULO : 04 / 04 / 2017

Tiago Furlan
Gerente de Qualidade
Johnson Controls



ESPECIFICAÇÃO DE PROCEDIMENTO DE SOLDAGEM (WELDING PROCEDURE SPECIFICATION)

EPS (WPS) : J 012 / 11

NORMA APLICAVEL (APPLICABLE CODE): ASME SEÇÃO IX, ED. 2019 COMPLEMENTAR (OTHER): -----

TESTES REQUERIDOS (REQUIRED TESTS): VISUAL, TRAÇÃO E DOBRAMENTO (VISUAL EXAMINATION, TENSION AND BEND TESTS)

PROCESSO DE SOLDAGEM (WELDING PROCESS): **MIG (GMAW)**

TIPO (TYPE): [] AUTOMÁTICO (AUTOMATIC) [X] SEMI-AUTOMÁTICO (SEMI-AUTO) [] MANUAL (MANUAL)

R.Q.P. SUPORTE Nº (SUPPORTING PQR Nº): J 012/11 DATA (DATE): 22/02/11

QW 402 JUNTAS (JOINTS)

TIPO DE CHANFRO (TYPE OF GROOVE): **CONFORME DESENHO DE FABRICAÇÃO (ACCORDING TO FABRICATION DRAWINGS)**

COBRE - JUNTA (BACKING): **NÃO (NO)** RETENTORES (RETAINERS): **NÃO USAR (N.U.)**

DETALHES DAS JUNTAS (JOINT DESIGN): **TOPO E ÂNGULO (BUTT AND FILLET JOINT)**

MATERIAL DO COBRE-JUNTA (BACKING MATERIAL): **NÃO (NO)** ABERTURA DE RAIZ (ROOT SPACING): **VER DESENHOS (SEE DRAWINGS)**

METODO DE PREPARAÇÃO (PREPARATION):
 GUILHOTINA / ESMERILHAMENTO (GUILLOTINE CUTTER / GRINDING)
 USINAGEM (MACHINING)
 OXICORTE / ESMERILHAMENTO (FLAME CUT / GRINDING)

OUTROS (OTHERS): **PARA OUTRO DETALHES DE JUNTAS, VER DESENHOS (SEE DRAWINGS FOR OTHERS JOINTS DETAILS)**

QW 403 METAL BASE (BASE METALS)

P Nº (P Nr) **1 GR. (GROUP) 1/2 x P Nº (P Nr) 1 GR. (GROUP) 1/2**

ESPECIF. (SPECIFIC.) TIPO E GRAU (TYPE AND GRADE): --
COM (TO)

ESPECIF. (SPECIFIC.) TIPO E GRAU (TYPE AND GRADE): --

FAIXA DE ESPESSURAS (THICKNESS RANGE)

METAL DE BASE : CHANFRO (GROOVE): **5,0 - 32 mm**

(BASE METAL) ÂNGULO (FILLET): **TODAS (ALL)**

FAIXA DE DIÂMETROS (PIPE DIAMETER RANGE) :

CHANFRO (GROOVE): **TODOS (ALL)**

ÂNGULO (FILLET): **TODOS (ALL)**

QW 405 POSIÇÃO DE SOLDAGEM (POSITION)

POSIÇÃO EM CHANFRO (GROOVE OF POSITION): **TODAS (ALL)**

PROGRESSÃO DA SOLD. GMAW :
(WELD. PROGRESSION) **ASCENDENTE (UPHILL)**

POSIÇÃO EM ÂNGULO (POSITION OF FILLET): **TODAS (ALL)**

QW 406 PRÉ-AQUECIMENTO (PRE HEAT)

TEMPERAT. PRÉ-AQUEC. MIN. (PRE HEAT TEMP. MIN.): $t \leq 25 \text{ mm} = 18^\circ \text{C}$
 $t > 25 \text{ mm} = 80^\circ \text{C}$

TEMP. INTERPASSES MAX. (INTER. TEMP. MAX.): **250°C**

PÓS AQUECIMENTO (PRE HEAT MAINTENANCE): **N. U. (N. U.)**

QW 408 GÁS (GAS)

GÁS DE PROTEÇÃO (SHIELDING GAS): **CO2 + Ar**

COMPOSIÇÃO (COMPOSITION): **25% CO2 + 75% Ar**

VAZÃO (FLOW RATE): **12 - 16 l / min. (liters / min.)**

GÁS DE PURGA (TRAINING GAS): **N. U. (NOT USED)**

PROTEÇÃO NA RAIZ (BACKING GAS): **NÃO USAR (N. U.)**

QW 409 CARACTERÍSTICAS ELÉTRICAS (ELECTRICAL CHARACTERISTICS)

CORRENTE (CURRENT): **CC (CONTINUOUS)** POLARIDADE (POLARITY): **INVERSA (+) (REVERSE)**

FAIXA DE CORRENTE (AMPER. RANGE): **100 - 240** FAIXA DE TENSÃO (VOLT RANGE): **18 - 24**

MODO DE TRANSFERENCIA (TRANSFER MODE): **CURTO CIRCUITO (SHORT-CIRCUIT)**

VELOCIDADE DO ARAME (FEED SPEED RANGE): **NÃO CONTROLADO (NOT CONTROLLED)**

ELETRODO DE TUNGSTENIO - TIPO E Ø (TUNGSTEN ELECTRODE - Ø AND TYPE): **NÃO USADO (N. U.)**

CAMADAS (LAYERS)	PROCESSO (PROCESS)	METAL DE ADIÇÃO (FILLER METAL)		CORRENTE (A) (CURRENT)		TENSÃO (V) (VOLT RANGE)	VELOC. AVANÇO (TRAVEL SPEED) cm / min.	OBS.
		CLASS	DIAM.	POLAR.	ÂMPER.			
INICIAL / OUTRAS (INITIAL & OTHERS)	MAG (GMAW)	ER 70 S6	1,2 mm	CC +	100-240	18 - 24	Não Controlado (Not Controlled)	----

QW 410 TÉCNICA DE SOLDAGEM (TECHNIQUE)

GOIVAGEM (METHOD BACK GOUGE): **NÃO USADO (N. U.)** PROCESSO TERMICO DE PREPARAÇÃO (THERMAL PROCESS): **NÃO USADO (N. U.)**

LIMPEZA INICIAL / INTERPASSES / FINAL (INITIAL, INTERPASS AND ENDED CLEANING): **ESCOVAR / ESMERILHAR (TO BRUSH / TO GRIND)**

DIÂM. BOCAL DO GÁS (GAS CUP SIZE): **16 mm** DISTANCIA BICO DE CONTATO (STICKOUT): **12 - 20 mm**

TIPO DE CORDÃO (TYPE OF BEAD): **FILETADO (STRINGER)** ELETRODOS (ELECTRODES): **SIMPLES (SINGLE)**

ESPAÇAMENTO ENTRE ELETRODOS (ELECTRODE SPACING): **N. A. (N. A.)**

OSCILAÇÃO MAX. (OSCILATION): **NÃO APLICAVEL (N. A.)** MUDANÇA CAMARA FECH. / ABERTA (CLOSED TO OUT CHAMBER): **NÃO USADO (N. U.)**

PASSES (PASS): **MULTI PLOS (MULTIPASS)** MARTELAMENTO (PEENING): **N. U. (N. U.)**

RESFRIAMENTO PÓS SOLDAGEM (POSTWELDING COOLING): **AO AR CALMO (AIR)**

OUTROS (OTHERS): **AS SUPERFÍCIES A SEREM SOLDADAS DEVEM ESTAR ISENTAS DE ÓLEO, GRAXA, CAREPAS, ETC. O ANTIRESPINGO**

PODE SER UTILIZADO DURANTE A SOLDAGEM (THE JOINTS CAN BE THE SURFACE CLEAN, FREE FROM THE OIL, GREASE AND CRAP.)

LISTA DE REVISÕES (REVISION): Rev. 1 DATA (DATE): 08/05/2014 - Correção Editorial (Editorial Correction)

Rev. 2 DATA (DATE): 25/08/2016 - Correção Editorial (Editorial Correction)

Rev. 3 DATA (DATE): 13/03/2017 - Correção Editorial (Editorial Correction)

Rev. 4 DATA (DATE): 04/04/2017 - Correção Editorial (Editorial Correction)

Rev. 5 DATA (DATE): 09/11/2020 - Correção Editorial (Editorial Correction)

DATA (DATE): 09/11/2020

Diogo Furlan
Quality Specialist
JOHNSON CONTROLS

REGISTRO DE QUALIFICAÇÃO DE PROCEDIMENTO DE SOLDAGEM
 (WELDING PROCEDURE QUALIFICATION RECORD)

RQPS (WPQR) Nº.: J 012 / 11

EPS (WPS) Nº.: J 012 / 11

PROCESSO DE SOLDAGEM (WELDING PROCESS) : GMAW

TIPO (TYPE) : SEMI-AUTOMÁTICO

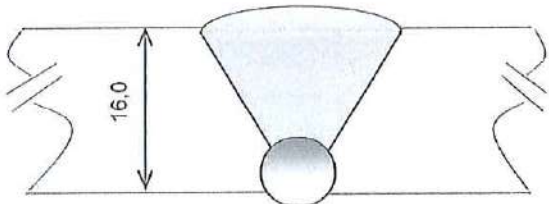
JUNTAS (JOINTS) QW 402

METAL BASE (BASE METAL) QW 403

ESPECIFICAÇÃO (SPECIFICATION) : SA 516 GR 70 x SA 516 GR 70

P Nº. (P Nr.) : 1 Gr. 2 x 1 Gr. 2

ESPESSURA DO CP (THICKNESS OF TC) : 16,0 mm

DIÂMETRO DO CP (DIAMETER OF TC) : -----

ESPESSURA DO PASSE (THICKNESS PASS) : < 13 mm

OUTROS (OTHERS) : CERTIFICADO COSIPA 213072

METAL DE ADIÇÃO (FILLER METAL) QW 404

DIÂMETRO (DIAMETER)

A Nº (A Nr.)

F Nº (F Nr.)

ESPECIFICAÇÃO (SPECIFICATION)

CLASSIFICAÇÃO (CLASSIFICATION)

METAL DEPOSITADO (WELD METAL)

METAL DE ADIÇÃO SUPLEMENT. (SUPPLEMENT FILLER METAL) : N.U. (NOT USED)

ELEMENTOS DE LIGA (ALLOY ELEMENTS) : NÃO USADO (N.U.)

FORMA DO PRODUTO (FILLER METAL PROD. FORM) : SÓLIDO (SOLID)

OUTROS (OTHERS) : CERT. ESAB corrida 7297500 CERT. NF059635

1º	DEMAIS (OTHERS)
1,2 mm	1,2 mm
ER 70S6	ER 70S6
6	6
SFA 5.18	SFA 5.18
ER 70S6	ER 70S6

16,0 mm (GMAW)

POSIÇÃO DE SOLDAGEM (POSITION) QW 405

POSIÇÃO DO CHANFRO (POSITION) : 3 G

PROGRESSÃO (WELD PROGRESSION) : ASCENDENTE (UPWARD)

OUTROS (OTHERS) : -----

PRÉ AQUECIMENTO (PRE HEAT) QW 406

TEMPERATURA PRÉ AQUECIMENTO (PRE HEAT TEMP.) : 18 °C

TEMPERATURA INTERPASSES (INTERPASS TEMP.) : 250 °C

OUTROS (OTHERS) : TERMOMETRO DE CONTATO

TRATAMENTO TÉRM. (POST WELD HEAT TRATAMENT) QW 407
 (NOT PERFORMED)

TEMPERATURA (TEMPERATURE RANGE) : N.A.

TEMPO DE PERMANENCIA (TIME RANGE) N.A.

OUTROS (OTHERS) -----

GAS (GAS) QW 408

GAS (SHIELDING GAS) : CO2 + AR

COMPOSIÇÃO (COMPOSITION) : 25% CO2 + 75% AR

VAZÃO (FLOW RATE) : 14,5 L

PROTEÇÃO NA RAIZ (BACKING GAS) : NÃO USADO (NOT USED)

CARACT. ELÉTRICAS (ELECTRICAL CHARACTERISTICS) QW 409

CORRENTE (CURRENT) : CONTINUA AMPERAGEM : 105 / 135 A

POLARIDADE (POLARITY) : INVERSA VOLT : 18,5 / 19 V

MODO DE TRANSFER. (MODE OF METAL TRANSFER) : CURTO-CIRC.

OUTROS (OTHERS) : -----

TÉCNICA (TECHNIQUE) QW 410

PASSE (PASS) : MÚLTIPLOS (MULTI PASS)

DEPOSIÇÃO (DEPOSITION) : RETILÍNEA (STRINGER PASS)

OSCILAÇÃO (OSCILATION) : -----

PROC. TÉRMICO DE PREPARAÇÃO (THERMAL PROCESS) : N.A. (N.A.)

OUTROS (OTHERS) : -----

PASSES (PASS) Nº (Nr.)	DIAM. (mm)	CORRENTE amperes	TENSÃO volts	VELOCIDADE DE TRABALHO (SPEED TRAVEL) cm / min.	OUTROS (OTHERS)
RAIZ	1,20	105	18,5	----	----
2º	1,20	120	19	----	----
3º	1,20	125	19	----	----
4º / 5º / 6º	1,20	130	19	----	----
7º / 8º / 9º	1,20	130	19	----	----
10º / 11º / 12º	1,20	135	19	----	----
13º / 14º / 15º	1,20	135	19	----	----
16º / 17º / 18º	1,20	135	19	----	----
19º / 20º / 21º / 22º	1,20	135	19	----	----



QW 150 ENSAIOS DE TRAÇÃO (TENSILE TEST)

CP Nº (SPECIMEN Nr.)	DIMENSÕES (DIMENSIONS) mm	AREA DA SECÇÃO (AREA) mm ²	CARGA TOTAL DE RUPTURA (ULTIMATE TOTAL LOAD) kgf	TENSÃO RUPTURA (ULTIMATE UNIT STRESS) MPA	LOCAL DA FRATURA (FAILURE LOCATION)
T1	18,79 X 16,11	302,71	18375	595	FORA DA SOLDA
T2	18,88 x 16,19	305,67	18455	590	FORA DA SOLDA

QW 160 ENSAIO DE DOBRAMENTO (BEND TEST)

TIPO E FIGURA Nº (TYPE AND FIGURE Nr.)	DIMENSÕES mm	RESULTADOS (RESULTS)
DOB. LATERAL 1 QW462.2	16,0 x 9,5	NÃO APRESENTOU DESCONTINUIDADES
DOB. LATERAL 2 QW462.2	16,0 x 9,5	NÃO APRESENTOU DESCONTINUIDADES
DOB. LATERAL 3 QW462.2	16,0 x 9,5	NÃO APRESENTOU DESCONTINUIDADES
DOB. LATERAL 4 QW462.2	16,0 x 9,5	NÃO APRESENTOU DESCONTINUIDADES

QW 170 ENSAIOS DE IMPACTO (IMPACT TEST)

TIPO: ----- (TYPE)		TEMPERATURA: ----- (TEMPERATURE)		DIMENSÃO DO CP: ----- (SPECIMEN DIMENSIONS)	
CP Nº. (SPECIMEN Nr.)	LOCAL DO ENTALHE (NOTCH LOCATION)	ENERGIA ABSORVIDA (Joules) (IMPACT VALUES)		EXPANSÃO LATERAL (LATERAL EXPANSION) mm	QUEDA DE PESO (DROP WEIGHT) RESULTADOS (RESULTS)
		INDIVIDUAL (INDIVID.)	MEDIA (AVERAGE)		
-----	-----	-----	-----	-----	-----
-----	-----	-----	-----	-----	-----
-----	-----	-----	-----	-----	-----
-----	-----	-----	-----	-----	-----
-----	-----	-----	-----	-----	-----
-----	-----	-----	-----	-----	-----
-----	-----	-----	-----	-----	-----
-----	-----	-----	-----	-----	-----
-----	-----	-----	-----	-----	-----

OBS. (OBSERVATIONS) 1- REGISTRO DE QUALIFICAÇÃO " APROVADO " CONFORME CERTIFICADO DE ENSAIOS DO LABORATÓRIO TORK 11036132MCSP

2- ENSAIO ADICIONAL DUREZA " HV 10 " RESULTADO FACE 178;178;180;197;210;220;198;202;202;216;220;194;182;174;176
RELATÓRIO 11036132MCSP FL. 2 / 2

NOME DO SOLDADOR (WELDERS NAME) : RODRIGO RAMOS DA SILVA
CARTEIRA PROF. Nº (WORK PERMIT. Nr.) : ----- SÉRIE --- SINETE (STAMP) W5

CERTIFICAMOS QUE AS INFORMAÇÕES DESTE REGISTRO SÃO CORRETAS E QUE AMOSTRA SOLDADA FOI PREPARADA , EXECUTADA E ENSAIADA CONFORME AS EXIGÊNCIAS DO CÓDIGO ASME SEÇÃO IX / 11.
WE CERTIFY THAT STATEMENTS IN THIS RECORD ARE CORRECT AND THAT THE TEST WELDS WERE PREPARED , WELDED AND TESTED IN ACCORDANCE WITH REQUIREMENTS OF ASME CODE SECTION IX / 11 .

SÃO PAULO : 04 / 04 / 2017



CONTROLE DE QUALIDADE
Tiago Furlan
Quality Especialist
Johnson Controls

Norma Aplicável (Applicable Code): **ASME SEÇÃO IX, ED. 2017** Complementar (Other): -----
 Testes Requeridos (Required Tests): **Visual, Tração e Dobramento** (Visual Examination, Tension and Bend Tests)

Processo de Soldagem (Welding Process): **FCAW**

Tipo (Type): [] Automático (Automatic) [**X**] Semi-Automático (Semi-Auto) [] Manual (Manual)

R Q P Suporte Nº (Supporting PQR Nº): **J 041/19**

DATA (DATE) : 20/04/2019

QW 402 JUNTAS (JOINTS)

Tipo de Chanfro (Type Of Groove): **Conforme Desenho de Fabricação** (According To Fabrication Drawings)

Cobre Junta (Backing): **Sim** (Yes)

Retentores (Retainers): **Não Usar** (N.U.)

Detalhes das Juntas (Joint Desing): **Topo e Ângulo** (Butt and Fillet Joint)

Material do Cobre Junta (Backing Material): **Metal de Solda** (Weld Metal)

Metodo de Preparação (Preparation):

Guilhotina/Esmerilhamento (Guillotine Cutter/Grinding)

Usinagem (Machining)

Oxicorte/Esmerilhamento (Flame Cut/Grinding)

Outros (Others): **Para outros detalhes de Juntas, Ver Desenhos** (See Drawings For Others Joint Details)

QW 403 METAL BASE (BASE METALS)

P Nº (P Nr) 1 GR. (Group) 1 / 2 x P Nº (P Nr) 1 GR. (Group) 1 / 2

Especif. (Specific.) Tipo e Grau (Type and Grade): --
Com (To)

Especif. (Specific.) Tipo e Grau (Type and Grade): --

Faixa de Espessuras (Thickness Range)

Metal de Base:
(Base Metal)

Chanfro (Groove): **5,0 - 38 mm**
Ângulo (Fillet): **Todas (All)**

Faixa de Diâmetros (Pipe Diameter Range):

Chanfro (Groove) : **Todos (All)**
Ângulo (Fillet) : **Todos (All)**

Outros (Others): **Nenhum passe maior que 13mm** (No Pass Greater Than 13mm)

QW 405 POSIÇÃO DE SOLDAGEM (POSITION)

Posição em Chanfro (Groove of Position): **Todas (All)**

Progressão da Soldagem:

(Welding Progression)

Ascendente (Uphill)

Posição em Ângulo (Position of Fillet): **Todas (All)**

QW 406 PRÉ-AQUECIMENTO (PRE HEAT)

Temp. de Pré Aquecimento Min. (Pre Heat Temp. Min.): $t \leq 25 \text{ mm} = 18^\circ \text{C}$

$t > 25 \text{ mm} = 80^\circ \text{C}$

Temp. Interpasse Máxima. (INTER. TEMP. MAX.): **250°C**

Manutenção do pré aquec. (PRE HEAT MAINTENANCE): **Não Usar** (N.U.)

QW 408 GÁS (GAS)

Gás de Proteção (Shielding Gas): **CO2**

Composição (Composition): **99% CO2**

Vazão (Flow Rate): **12 - 16 l/min.** (liters/min.)

Proteção da Raiz (Backing Gas): **Não Usado** (N. U.)

QW 409 CARACTERÍSTICAS ELÉTRICAS (ELECTRICAL CHARACTERISTICS)

Corrente (Current): **CC** (Continuous)

POLARIDADE (POLARITY): **INVERSA (+)** (REVERSE)

Faixa de Corrente (Amper. Range): **150 - 240 A**

Faixa de Tensão (Volt Range): **20 - 28 V**

Modo de Transferencia (Transfer Mode): **Spray**

Velocidade do Arame (Feed Speed Range): **Não Controlado** (Not Controlled)

Eletrodo de Tungstenio - Tipo e Ø (Tungsten Electrode - Ø and Type): **Não Aplicado** (N.A.)

CÂMADAS (LAYERS)	PROCESSO (PROCESS)	METAL DE ADIÇÃO (FILLER METAL)		CORRENTE (A) (CURRENT)		TENSÃO (V) (VOLT RANGE)	VELOC. AVANÇO (TRAVEL SPEED) cm / min.	OBS.
		CLASS	DIAM.	POLAR.	ÂMPER.			
Inicial/Outras (Initial & Others)	FCAW	E71 T-1	1,2 mm	CC +	150-240	20 - 28	Não Controlado (Not Controlled)	-----

QW 410 TÉCNICA DE SOLDAGEM (TECHNIQUE)

Goivagem (Back Gauge): **Esmerilhar, Goivagem** (To grind, Arc Gouging) Processo Term. Preparação (Thermal Process): **Não Usado** (N.U.)

Limpeza Inicial/Interpasse Final (Initial, Interpass and Ended Cleaning): **Escovar / Esmerilhar** (To Brush / To Grind)

Diam. Bocal do Gás (Gas Cup Size): **16 mm**

Distancia Bico de Contato (Stickout): **12 - 20 mm**

Tipo de Cordão (Type of Bead): **Estreito ou Oscilado** (String or Weave) Eletrodos (Electrodes): **Simple** (Single)

Espaçamento Entre Eletrodos (Electrode Spacing): **Não Aplicado** (N.A.)

Oscilação máx. (Oscillation): **Não Controlado** (Not Controlled) Mudança Camara Fech. PI Aberta (Closed To Out Chamber): **Não Usado** (N.U.)

Passes (Pass): **Multiplos** (Mullpass)

Martelamento (Peening): **Não Usado** (N. U.)

Resfriamento Pós Soldagem (Postwelding Cooling): **Ao Ar Calmo** (Air)

Outros (Others): **As superficie a serem soldadas devem estar isenta de oleo, graxa, carepas, etc.. O antirespingo pode ser utilizado durante a soldagem.** (The joint can be the surface clean, free from the oil, grease and crap.)

LISTA DE REVISÕES (REVISION): Rev. 0 DATA (DATE) : 03/04/2019 - Emissão Inicial

Rev. 1 DATA (DATE) : 14/07/2020 - Correção Editorial (Editorial Correction)

DATA (DATE) : 14/07/2020

Tiago Furlan

Quality Specialist

Johnson Controls

JOHNSON CONTROLS

REGISTRO DE QUALIFICAÇÃO DE PROCEDIMENTO DE SOLDAGEM
 (WELDING PROCEDURE QUALIFICATION RECORD)

DATA (DATE) 25/04/2019

RQPS (PQR) N°.: J041/19

EPS (WPS) N°.: J041 /19

Processo de Soldagem (Welding Process): FCAW

Tipo (Type): Semi-Automático

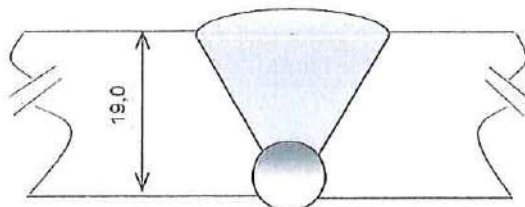
JUNTAS (JOINTS) QW 402

METAL BASE (BASE METAL) QW 403

 Especificação (Specification) : SA 516 GR.70 x AS 516 GR.70
 P N° (P Nr.) : 1 Gr. 2 x 1 Gr. 2
 Espessura do CP (Thickness of Coupon): 19,0 mm
 Diâmetro do CP (Diameter of Coupon): -----
 Espessura do Passe (Thickness): < 13 mm
 Limitação T [Curto-Circuito] (Limits T [short-Circuiting]) NA
 Outros (Others) : Certificado Gerdau corr. 27105169

METAL DE ADIÇÃO (FILLER METAL) QW 404

	1°	Demais (Others)
Camadas (Layers)		
Diâmetro (Diameter)	1,2 mm	1,2 mm
A N° (A Nr.)	E71 T-1	E71 T-1
F N° (F Nr.)	6	6

 Especificação (Specification) SFA 5.36 SFA 5.36
 Classificação (Classification) E71 T-1 E71 T-1

 Metal Depositado (Weld Metal Thickness): 19mm (FCAW)
 Met. de Adic. Suplen.(Supplement Filler Metal): Não Usado (N.U.)
 Elementos de Liga (Alloy Elements) : Não Usado (N.U.)
 Forma do Produto (Filler Metal Product Form): Tubular (Flux Cored)
 Limitação t [Curto-Circuito] (Limits T [short-Circuiting]) N.A.
 Outros (Others):

POSIÇÃO DE SOLDAGEM (POSITION) QW 405

 Posição do Chanfro (Position of Groove) : 3 G
 Progressão (Weld Progression): Ascendente (UPhill)
 Outros (Others): -----

PRÉ AQUECIMENTO (PRE HEAT) QW 406

 Temperatura Pré-Aquecim. (Pre Heat Temper.): 18 °C
 Temperatura Interpasse (Interpass Temp.): 250 °C
 Outros (Others) : Termometro de Contato

TRATAMENTO TÉRM. (POST WELD HEAT TRATAMENT) QW 407
 Não Usado (Not Performed)

 Temperatura (Temperature Range) : Não Usado (N.U.)
 Tempo de Permanencia (Time Range): Não Usado (N.U.)
 Outros (Others) -----

GAS (GAS) QW 408

 Gas (Shielding Gas): CO2
 Purga (Trailing) Não Usado (N.U.)
 Vazão (Flow Rate) : 18 L/min
 Proteção da Raiz (Backing Gas) : Não Usado (N.U.)

CARAC. ELÉTR. (ELECTR. CHARACTERISTICS) QW 409

 Corrente (Current) : Contínua Amperagem: 160 - 220 A
 Polaridade (Polarity): Inversa Volt: 21 - 26 V
 Modo de Transfer. (Mode of Metal transfer): Spray
 Outros (Others) : -----

TÉCNICA (TECHNIQUE) QW 410

 Passe (Pass) : Múltiplos (Mult Pass)
 Deposição (Deposition): Retilínea (Stringer Pass)
 Oscilação (Oscillation) : Não Usado (N.U.)
 Proc. Term. de Prep. (Thermal Process) : N.A. (N.A.)
 Outros (Others) : -----

Passes (Pass)	Camadas (Layers)	Diam.	Corrente (Corrent)	Tensão (Volt)	Velocidade de Trabalho (Speed Travel)	Outros (Others)
N° (Nr.)	N° (Nr.)	[mm]	[A]	[V]	[cm/min.]	
Raiz (Root)		1,20	160	21	-----	-----
2	2	1,20	200	23	-----	-----
3	3	1,20	200	25	-----	-----
4	3	1,20	215	25	-----	-----
5	4	1,20	220	24	-----	-----
6	4	1,20	220	26	-----	-----
7	5	1,20	210	25	-----	-----
8	5	1,20	210	24	-----	-----
9	5	1,20	210	24	-----	-----
Goivagem a Arco						
10	6	1,20	210	25	-----	-----
11	7	1,20	220	25	-----	-----
12	8	1,20	210	24	-----	-----
13	8	1,20	210	24	-----	-----



QW 150 ENSAIOS DE TRAÇÃO (TENSION TEST)

CP Nº (Specimen Nr.)	Dimensões (Dimensions) [mm]	Area da Secção (Area) [mm ²]	Carga Total de Ruptura (Ultimate Total Load) [kgf]	Tensão Ruptura (Ultimate Unit Stress) [Mpa]	Local da Fratura (Failure Location)
T1	19,01 x 18,25	346,93	19190	540	FORA DA SOLDA
T2	18,97 x 18,46	350,19	19350	540	FORA DA SOLDA

QW 160 ENSAIO DE DOBRAMENTO (BEND TEST)

Tipo e Figura Nº (Type and Figure Nr.)	Dimensões [mm]	Resultados (Results)
Dobramento Lateral 1 QW462.2	19,0 x 10,0	NÃO APRESENTOU DESCONTINUIDADES
Dobramento Lateral 2 QW462.2	19,0 x 10,0	NÃO APRESENTOU DESCONTINUIDADES
Dobramento Lateral 3 QW462.2	19,0 x 10,0	NÃO APRESENTOU DESCONTINUIDADES
Dobramento Lateral 4 QW462.2	19,0 x 10,0	NÃO APRESENTOU DESCONTINUIDADES

QW 170 ENSAIOS DE IMPACTO (TOUGHNESS TEST)

Tipo: ----- (Type)		Temperatura: ----- (Temperature)		Dimensão do CP: ----- (Specimen Dimension)	
CP Nº. (Specimen Nr.)	Local do entalhe (Notch Location)	Energia Absorvida [Joules] (Impact Values)		Expansão Lateral (Lateral Expansion) [mm]	Queda do Peso (Drop Weight) Resultados (Results)
		Individual (Individ.)	Média (Average)		
-----	-----	-----	-----	-----	-----
-----	-----	-----	-----	-----	-----
-----	-----	-----	-----	-----	-----
-----	-----	-----	-----	-----	-----
-----	-----	-----	-----	-----	-----
-----	-----	-----	-----	-----	-----
-----	-----	-----	-----	-----	-----
-----	-----	-----	-----	-----	-----
-----	-----	-----	-----	-----	-----
-----	-----	-----	-----	-----	-----

OBS. (Observations) 1- Registro de Qualificação "APROVADO " Conforme Certificado de Ensaio do Laboratório TORC 1904767MCSP

2- ENSAIO ADICIONAL DUREZA "HV 10 "

EIXO I	154	161	216	220	183	193	222	217	210	153
EIXO II	159	210	213	209	183	179	224	216	193	150

Nome do Soldador (Welders Name) : JOSE ROBERTO BATISTA SILVA Sinete (Stamp): PZ

Certificamos que as informações deste registro são corretas e que a amostra soldada foi preparada, executada e ensaiada conforme as exigências do código ASME Seção IX Ed.2017

We certify that statements in this record are correct and that the test welds were prepared, welded and tested in accordance with requirements of ASME code section IX Ed.2017

SOROCABA : 25 / 04 / 2019



 Tiago Furlan
 Quality Specialist
 Johnson Controls

ESPECIFICAÇÃO DE PROCEDIMENTO DE SOLDAGEM (WELDING PROCEDURE SPECIFICATION)

EPS (WPS) : SB 017 / 00

NORMA APLICAVEL (APLICABLE CODE) : ASME SEÇÃO IX , ED. 1998 COMPLEMENTAR (OTHER) : -----
TESTES REQUERIDOS (REQUIRED TESTS) : VISUAL , TRAÇÃO E DOBRAMENTO (VISUAL EXAMINATION , TENSION AND BEND TESTS)

PROCESSO DE SOLDAGEM (WELDING PROCESS) : **MAG (GMAW) + ARCO SUBMERSO (SAW)**
TIPO (TYPE) : [X] MECANIZADO SAW (MECHANICAL) [X] SEMI-AUTOMÁTICO GMAW (SEMI-AUTOMATIC)
R.Q.P. SUPORTE Nº (SUPPORTING PQR Nº) : SB 022 / 00 ; SB 022A / 00 DATA (DATE) : 01/12/2000

QW 402 JUNTAS (JOINTS)
TIPO DE CHANFRO (TYPE OF GROOVE) : CONFORME DESENHO DE FABRICAÇÃO (ACCORDING TO FABRICATION DRAWINGS)
COBRE - JUNTA (BACKING) : MAG - NÃO (NO) ; SAW - SIM (YES) RETENTORES (RETAINERS) : NÃO USADO (N.U.)
DETALHES DAS JUNTAS (JOINT DESIGN) : TOPO E ÂNGULO (BUTT AND FILLET JOINT)
MATERIAL DO COBRE-JUNTA (BACKING MATERIAL) : NÃO (NO)
METODO DE PREPARAÇÃO (PREPARATION) :
GUILHOTINA / ESMERILHAMENTO (GUILLOTINE CUTTER / GRINDING)
USINAGEM (MACHINING)
OXICORTE / ESMERILHAMENTO (FLAME CUT / GRINDING)
OUTROS (OTHERS) : PARA OUTRO DETALHES DE JUNTAS , VER DESENHOS (SEE DRAWINGS FOR OTHERS JOINTS DETAILS)

QW 403 METAL BASE (BASE METALS)
P Nº (P Nr) 1 GR. (GROUP) 1 / 2 x P Nº (P Nr) 1 GR. (GROUP) 1 / 2
ESPECIF. (SPECIFIC.) TIPO E GRAU (TYPE AND GRADE) : --
COM (TO)
ESPECIF. (SPECIFIC.) TIPO E GRAU (TYPE AND GRADE) : --
FAIXA DE ESPESSURAS (THICKNESS RANGE)
METAL DE BASE :
(BASE METAL)
CHANFRO (GROOVE) : 5,0 - 32,0 mm
ÂNGULO (FILLET) : TODAS (ALL)
FAIXA DE DIÂMETROS (PIPE DIAMETER RANGE) :
CHANFRO (GROOVE) : TODOS (ALL)
ÂNGULO (FILLET) : TODOS (ALL)

QW 404 METAL DE ADIÇÃO (FILLER METAL)
ESPEC. (SPECIF.) SFA : 5.18 / 5.17 F Nº : 6
CLASSE (CLASS.)
AWS : EM12KF7A4 A Nº : 1
AWS : ER 70S6 A Nº : ER 70S6
TIPO DE FLUXO (TYPE OF FLUX) : NEUTRO (NEUTRAL)
DIÂMETROS (DIAMETERS) : 1, 2 mm (GMAW) ; 3,2 mm (SAW)
FORMA DO PRODUTO (FILLER METAL PROD. FORM) : SÓLIDO (SOLID)
ELEMENTOS DE LIGA (ALLOY ELEMENTS) : Não Controlado (N.C.)
ESPESSURA DO PASSE (PASS THICKNESS) : 13 mm Max.
FAIXA DE ESPES. METAL DEPOSIT. (WELD METAL THICK. RANGE) :
CHANFRO (GROOVE) : 6,0 mm Max. (GMAW) ; 26,0 mm Max. (SAW)
ÂNGULO (FILLET) : TODAS (ALL)
MARCA COMERCIAL (TRADE MARK) : ESTOQUE (STOCK)
METAL DE ADIÇÃO SUPLEM. (SUPPLEMENT FILLER METAL) : Não Usado (N.U.)
ESCÓRIA RECICLADA (RECRUSHED SLAG) : NÃO USADO (N.U.)

QW 405 POSIÇÃO DE SOLDAGEM (POSITION)
POSIÇÃO DO CHANFRO :
(GROOVE OF POSITION)
PLANA - SAW (FLAT)
TODAS - MAG (ALL - GMAW)
PROGRESSÃO DA SOLD. GMAW :
(WELD. PROGRESSION)
ASCENDENTE (UPHILL)
DESCENDENTE (DOWNHILL)
POSIÇÃO EM ÂNGULO (POSITION OF FILLET) : TODAS (ALL)

QW 406 PRE-AQUECIMENTO (PRE HEAT)
TEMPERAT. PRÉ-AQUEC. MIN. :
(PRE HEAT TEMP. MIN.)
t < 25 mm - 18° C
t ≥ 25 mm - 80° C
TEMP. INTERPASSES MÁX. (INTER. TEMP. MAX.) : 250° C
TECNICA DE APLICAÇÃO (HEATING TECHNIQUE) : N. U. (N.U.)
PÓS AQUECIMENTO (PRE HEAT MAINTENANCE) : N. U. (N.U.)

QW 407 TRAT. TÉRMICO (POSTWELD HEAT TREATMENT)
TIPO (TYPE) : NÃO USADO (N. U.)
GRADIENTE AQUEC. (HEATING TAX.) : N. U. (NOT USED)
TEMPERATURA (TEMPERATURE RANGE) : N. U. (N. U.)
TEMPO DE PERMANENCIA (TIME RANGE) : N. U. (N. U.)
GRADIENTE RESFR. (COOLING TAX.) : N. U. (N. U.)

QW 408 GÁS (GAS)
GÁS DE PROTEÇÃO (SHIELDING GAS) : CO₂ + Ar
COMPOSIÇÃO (COMPOSITION) : 25% CO₂ + 75% Ar
VAZÃO (FLOW RATE) : 12 - 15 l / min. (liters / min.)
PROTEÇÃO NA RAIZ (BACKING GAS) : NÃO USADO (N. U.)

QW 409 CARACTERÍSTICAS ELÉTRICAS (ELECTRICAL CHARACTERISTICS)
CORRENTE (CURRENT) : CC (CONTINUOUS) POLARIDADE (POLARITY) : INVERSA (+) (REVERSE)
FAIXA DE CORRENTE (AMPER. RANGE) : 100 - 240 (GMAW) ; 380 - 500 (SAW) FAIXA DE TENSÃO (VOLT RANGE) : 18 - 22 (GMAW) ; 30 - 38 (SAW)
MODO DE TRANSFERENCIA (TRANSFER MODE) : CURTO CIRCUITO (SHORT - CIRCUIT)
VELOC. DO ARAME (FEED SPEED RANGE) : 5,0 - 6,0 mts / min. ELETR. DE TUNGSTENIO-TIPO E Ø (TUNGSTEN ELECTRODE - Ø AND TYPE) : N. U. (N. U.)

CAMADAS (LAYERS)	PROCESSO (PROCESS)	METAL DE ADIÇÃO (FILLER METAL)		CORRENTE (A) (CURRENT)		TENSÃO (V) (VOLT RANGE)	VELOC. AVANÇO (TRAVEL SPEED) cm / min.	OBS.
		CLASS.	DIAM.	POLAR.	AMPER.			
RAIZ (ROOT)	MAG (GMAW)	ER 70 S6	1,2 mm	CC+	100-240	18-22	Não Controlado (Not Controlled)	-----
DEMAIS (OTHERS)	SAW	EM12K	3,2 mm	CC+	380-500	30-38		

QW 410 TÉCNICA DE SOLDAGEM (TECHNIQUE)
GOIVAGEM (METHOD BACK GOUGE) : NÃO USADO (N.U.) PROCESSO TÉRMICO DE PREPARAÇÃO (THERMAL PROCESS) : NÃO USADO (N.U.)
LIMPEZA INICIAL / INTERPASSES / FINAL (INITIAL , INTERPASS AND ENDED CLEANING) : ESCOVAR / ESMERILHAR (TO BRUSH / TO GRIND)
DIÂM. BOCAL DO GÁS (GAS CUP SIZE) : 16 mm DISTANCIA BICO DE CONTATO (STICKOUT) : 12 - 20 mm
TIPO DE CORDÃO (TYPE OF BEAD) : FILETADO (STRINGER) ELETRODOS (ELECTRODES) : SIMPLES (SINGLE)
OSCILAÇÃO MAX. (OSCILATION) : NÃO USADO (N.U.) MUDANÇA CAMARA FECH. PIABERTA (CLOSED TO OUT CHAMBER) : NÃO USADO (N.U.)
PASSOS (PASS) : MULTI PLOS (MULTIPASS) MARTELAMENTO (PEENING) : N. U. (N. U.)
RESFRIAMENTO PÓS SOLDAGEM (POSTWELDING COOLING) : AO AR CALMO (AIR)
OUTROS (OTHERS) : AS SUPERFÍCIES A SEREM SOLDADAS DEVEM ESTAR ISENTAS DE ÓLEO , GRAXA , CAREPAS , ETC. O ANTIRESPINGO PODE SER UTILIZADO DURANTE A SOLDAGEM . (THE JOINTS CAN BE THE SURFACE CLEAN , FREE FROM THE OIL , GREASE AND CRAP .)

LISTA DE REVISÕES (REVISION) :
Rev. 1 DATA (DATE) : 08/05/2014 - Correção Editorial (Editorial Correction)
Rev. 2 DATA (DATE) : 25/08/2016 - Correção Editorial (Editorial Correction)
Rev. 3 DATA (DATE) : 13/03/2017 - Correção Editorial (Editorial Correction)

DATA (DATE) : 13/3/2017

Quality Specialist
Johnson Controls



REGISTRO DE QUALIFICAÇÃO DE PROCEDIMENTO DE SOLDAGEM
(WELDING PROCEDURE QUALIFICATION RECORD)

FOLHA (PAGE) 1 / 2

DATA (DATE) 06 / 12 / 00

RQPS (WPQR) Nº. : **SB 022 / 00**

EPS (WPS) Nº.: SB 017 / 00

PROCESSO DE SOLDAGEM (WELDING PROCESS) : **GMAW + SAW**

TIPO (TYPE) : SEMI + AUTOMATICO

JUNTAS (JOINTS) QW 402

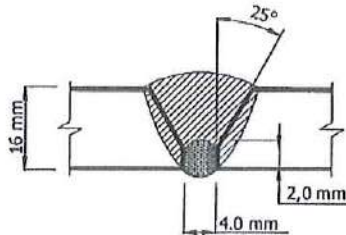

METAL BASE (BASE METAL) QW 403

ESPECIFICAÇÃO (SPECIFICATION) : SA 516 Gr 60 X SA 516 Gr 60
P Nº. (P No.) : 1 x 1 P Nº. (P No.)
ESPESSURA DO CP (THICKNESS OF TC) : 16,0 mm
DIÂMETRO DO CP (DIAMETER OF TC) : _____
OUTROS (OTHERS) : CERTIFICADO COSIPA 103347
CP IMPACTO COSIPA 802227 16 mm

METAL DE ADIÇÃO (FILLER METAL) QW 404

DIÂMETRO (DIAMETER)

A Nº (A Nr.)

F Nº (F Nr.)

ESPECIFICAÇÃO (SPECIFICATION)

CLASSIFICAÇÃO (CLASSIFICATION)

RAIZ (ROOT)	DEMAIS (OTHERS)
1,2 MM	3,18 mm
1	1
6	6
SFA 5.18	SFA 5.17
ER 70S6	EM 12KF7A4

METAL DEPOSITADO (WELD METAL) { 6,0 mm (GMAW)
10,0 mm (SAW)

OUTROS (OTHERS) : CERTIFICADO ESAB 001108 (FLUXO) ;
CERT. ESAB 351 (MAG) ; CERTIFICADO AIR LIQUIDE 1347 (SAW)

POSIÇÃO DE SOLDAGEM (POSITION) QW 405

POSIÇÃO DO CHANFRO (POSITION) : 1G

PROGRESSÃO (WELD PROGRESSION) _____

OUTROS (OTHERS) : _____

PRÉ AQUECIMENTO (PRE HEAT) QW 406

TEMPERATURA PRÉ AQUECIMENTO (PRE HEAT TEMP.) : 20 °C
TEMPERATURA. INTERPASSES (INTERPASS TEMP.) : 250 °C
OUTROS (OTHERS) : CONTROLE POR TERMÔMETRO DE
CONTATO

TRATAMENTO TÉRMICO (POST WELD HEAT TREATMENT) QW 407

TEMPERATURA (TEMPERATURE RANGE) _____

TEMPO DE PERMANENCIA (TIME RANGE) _____

OUTROS (OTHERS) _____

GAS (GAS) QW 408

TIPO (TYPE) : ARGÔNIO + CO2

COMPOSIÇÃO (COMPOSITION) : 75 % + 25 %

VAZÃO (FLOW RATE) : 10 l / min.

OUTROS (OTHERS) : _____

CARACT. ELÉTRICAS (ELECTRICAL CHARACTERISTICS) QW 409

CORRENTE (CURRENT) : CONTINUA AMPERAGEM : 120 / 500

POLARIDADE (POLARITY) : INVERSA VOLT : 22 / 32

MODO DE TRANSFER. (MODE OF METAL TRANSFER) :

CURTO - CIRCUITO (GMAW)

OUTROS (OTHERS) : _____

TÉCNICA (TECHNIQUE) QW 410

PASSE (PASS) : MULTIPLOS

DEPOSIÇÃO (DEPOSITION) : FILETADO

OSCILAÇÃO (OSCILATION) : _____

OUTROS (OTHERS) : LIMPEZA INTERPASSES PARA REMOÇÃO
DE IMPERFEIÇÕES VISUAIS

PASSES (PASS) Nº (Nr.)	DIAM . (mm)	CORRENTE AMPS	TENSÃO VOLTS	VELOCIDADE DE TRABALHO (SPEED TRAVEL) cm / min.	OUTROS (OTHERS) Heat-input
1º / 2º	1,2	130 ± 10	22 ± 1	10	19,3 kJ/cm
DEMAIS	3,18	450 ± 50	31 ± 1	45	21,3 kJ/cm

[Handwritten signature and stamp]

RQPN° (PQRNr.) 22 / 00
FOLHA (PAGE) 02/02

QW 150 ENSAIOS DE TRAÇÃO (TENSILE TEST)

CP N° (SPECIMEN Nr.)	DIMENSÕES (DIMENSIONS) mm	AREA DA SECCÃO (AREA) mm ²	CARGA TOTAL DE RUPTURA (ULTIMATE TOTAL LOAD) N	TENSÃO RUPTURA (ULTIMATE UNIT STRESS) N/mm ²	LOCAL DA FRATURA (FAILURE LOCATION)
T1	19,77 X 14,97	295 ,96	1596,3	520	NA SOLDA
T2	20,10 x 14,85	298 ,48	1611,6	520	NA SOLDA

QW 160 ENSAIO DE DOBRAMENTO (BEND TEST)

TIPO E FIGURA N° (TYPE AND FIGURE Nr.)	RESULTADOS (RESULTS)
DOB. LATERAL 1 QW462.2	NÃO APRESENTOU DESCONTINUIDADES
DOB. LATERAL 2 QW462.2	NÃO APRESENTOU DESCONTINUIDADES
DOB. LATERAL 3 QW462.2	NÃO APRESENTOU DESCONTINUIDADES
DOB. LATERAL 4 QW462.2	NÃO APRESENTOU DESCONTINUIDADES

QW 170 ENSAIOS DE IMPACTO (IMPACT TEST)

CP No. (SPECIMEN Nr.)	LOCAL DO ENTALHE (NOTCH LOCATION)	ENERGIA ABSORVIDA (IMPACT VALUES) J		EXPANSÃO LATERAL (LATERAL EXPANSION) mm	QUEDA DE PESO (DROP WEIGHT) RESULTADOS (RESULTS)
		INDIVIDUAL (INDIVID.)	MEDIA (AVERAGE)		
1	CENTRO DE SOLDA	62		-----	-----
2	CENTRO DE SOLDA	16	53	-----	-----
3	CENTRO DE SOLDA	81		-----	-----
4	Z. T. A	26		-----	-----
5	Z. T. A	42	33	-----	-----
6	Z. T. A	31		-----	-----

OBS. (OBSERVATIONS) REGISTRO DE QUALIFICAÇÃO " APROVADO " CONFORME CERTIFICADOS DE
ENSAIO 00122325MC E 00122324MC DO LABORATÓRIO TORKNOME DO SOLDADOR (WELDERS NAME) : SEBASTIAO BEZERRA DE LIMA
CARTEIRA PROF. N° (WORK PERMIT. Nr.) : --- SÉRIE SINETE (STAMP) BBCERTIFICAMOS QUE AS INFORMAÇÕES DESTE REGISTRO SÃO CORRETAS E QUE AMOSTRA SOLDADA
FOI PREPARADA , EXECUTADA E ENSAIADA CONFORME AS EXIGÊNCIAS DO CÓDIGO ASME SEÇÃO IX / 98.
WE CERTIFY THAT STATEMENTS IN THIS RECORD ARE CORRECT AND THAT THE TEST WELDS WERE
PREPARED , WELDED AND TESTED IN ACCORDANCE WITH REQUIREMENTS OF ASME CODE SECTION IX / 98 .

SÃO PAULO : 06 / 12 / 00

Rebeca A. ... Filho
TECNICISTA DE SOLDAS
CONTROLE DE QUALIDADE

Johnson Controls		REGISTRO DE QUALIFICAÇÃO DE SOLDADOR/OPERADOR (WELDER OR WELDING OPERATOR QUALIFICATION TEST)		Nº RQ 238
SOLDADOR (WELDER): José de Lima Proença		SINETE (STAMP): FQ		PAG. (PAGE) 1/1
PROCESSO (PROCESS): FCAW		TIPO (TYPE): SEMI-AUTOMÁTICO		
EPS Nº (WPS Nr): J041/19		REVISÃO (REVISION): 0		
VARIÁVEIS (VARIABLES)		DADOS DO TESTE (ACTUAL VALUES)	FAIXA DE QUALIFICAÇÃO (RANGE QUALIFIED)	
QW 402	COBRE - JUNTA (BACKING)	SEM (NO)	SEM / COM (WITH OR NO BACKING)	
QW 403	ESPECIFICAÇÃO (SPECIFICATION)	SA 516 Gr 70	-----	
MATERIAL BASE (BASE METAL)	GRUPO P No. (P. NUMBER)	P1 Gr 1	P1 a P15F ; P34 ; P41 a P49	
	ESPESSURA (THICKNESS) JUNTA DA TOPO (GROOVE WELD)	16,0 mm	ILIMITADO (UNLIMITED)	
	JUNTA ÂNGULO (FILLET WELD)	NÃO USADO (NOT USED)	ILIMITADO (UNLIMITED)	
	DIAMETRO (DIAMETER) JUNTA DA TOPO (GROOVE WELD)	N. A. (NOT APPLICABLE)	(> Ø EXT. 73mm) (OUTSIDE Ø 73mm)	
	JUNTA ÂNGULO (FILLET WELD)	NÃO USADO (NOT USED)	ILIMITADO (UNLIMITED)	
QW 404	ESPECIFICAÇÃO (SFA)	SFA 5.36	SFA 5.36	
METAL DE ADIÇÃO (FILLER METAL)	CLASSIFICAÇÃO (CLASSIFICATION)	E71 T-1	QW 432	
	F NUMERO (F Nr)	6	6	
	FORMA DO CONSUMÍVEL (FILLER MET. PRODUCT FORM)	TUBULAR (FLUX CORED)	TUBULAR OU SÓLIDO (FLUX CORED OR SOLID)	
	METAL DEPOSITADO (WELD DEPOSITION)	16,0 mm (> 3 CAMADAS) (> 3 LAYERS)	TOPO (BUTT) ILIMIT. (UNLIMITED) ÂNGULO (FILLET) : ILIMITADO (UNLIMITED)	
Limitação T [Curto-Circuito] (Limits T [short-Circuiting])	N. A. (NOT APPLICABLE)	N. A. (NOT APPLICABLE)		
QW 405	POSIÇÃO (WELD POSITION)	2G 3G	Ø > 610 - P,H,V (Ø > 610 - F,H,V) 73 ≤ Ø ≤ 610 - P, H (73 < Ø < 610 - F,H) FILETE - P, V, H (FILLET - F, V, H)	
(POSITION)	PROGRESSÃO (PROGRESSION)	ASCENDENTE (UPHILL)	ASCENDENTE (UPHILL)	
QW 408	TIPO (TYPE)	CO2 (CO2)	CO2 (CO2)	
GAS (GAS)	PROTEÇÃO NA RAIZ (BACKING GAS)	SEM (WITHOUT)	COM / SEM (WITH / WITHOUT)	
QW 409	CORRENTE (CURRENT)	CONTINUA (DIRECT)	CONTINUA (DIRECT)	
CAR.ELET. (ELECTRICAL CHARACTER.)	POLARIDADE (POLARITY)	INVERSA (REVERSE)	INVERSA (REVERSE)	
	MODO DE TRANSFERENCIA (GMAW) (MODE OF METAL TRANSFER. GMAW)	SPRAY (SPRAY)	SPRAY GLOBULAR E PULSADO (PULSED)	
QW 360	CONTROLE VISUAL (DIRECT VISUAL CONTROL)	NÃO APLICAVEL (NOT APPLICABLE)	NÃO APLICAVEL (NOT APPLICABLE)	
VARIÁVEIS OPERADOR SOLDAGEM (WELDING VARIABLES OPERATOR)	CONTROLE AUTOMÁTICO DE VOLTAGEM (AUTOMATIC ARC VOLTAGE CONTROL)	NÃO APLICAVEL (NOT APPLICABLE)	NÃO APLICAVEL (NOT APPLICABLE)	
	LOCALIZAÇÃO DA JUNTA (JOINT TRACKING)	NÃO APLICAVEL (NOT APPLICABLE)	NÃO APLICAVEL (NOT APPLICABLE)	
	INSERTO CONSUMIVEL (CONSUMABLE INSERTS)	NÃO APLICAVEL (NOT APPLICABLE)	NÃO APLICAVEL (NOT APPLICABLE)	
	PROTEÇÃO (BACKING)	NÃO APLICAVEL (NOT APPLICABLE)	NÃO APLICAVEL (NOT APPLICABLE)	
	PASSES SIMPLES/MULTIPLA (MULTIPLE OR SINGLE PASS)	NÃO APLICAVEL (NOT APPLICABLE)	NÃO APLICAVEL (NOT APPLICABLE)	
			NÃO APLICAVEL (NOT APPLICABLE)	NÃO APLICAVEL (NOT APPLICABLE)
QW 191	ENSAIO RADIOGRAFICO (RADIOGRAPHIC TEST)	Satisfatório (Satisfactory)		
QW 191.2	ENSAIO ULTRASSOM (ULTRASONIC TEST)	Não Aplicavel (Not Applicable)		
QW 302.4	EXAME VISUAL (VISUAL EXAMINATION)	Aprovado (Approved)		
(QW 462. 3) ENSAIO DE DOBRAMENTO (BEND TEST)				
TIPO DE C.P. (TYPE AND FIGURE)	TIPO/IDENTIFICAÇÃO (IDENTIFICATION/TYPE)	AVALIAÇÃO DOS CP's (EVALUATION)		RESULTADO (RESULT)
A- TRANSVERSAL (TRANSVERSE)	---	---		---
B- LONGITUDINAL (LONGITUDINAL)	---	---		---
1 - RAIZ (ROOT)	---	---		---
2 - FACE (FACE)	---	---		---
3 - LATERAL (SIDE)	---	---		---
(QW 462. 4) SOLDA DE FILETE (FILLET WELD) :	Não Aplicavel (Not Applicable)			
TESTE CONDUZIDO POR (TESTS CONDUCTED BY) :	Tiago Furlan			
TESTE DE LABORATORIO (LABORATORY TEST Nr.) :	METALTEC-EBE RELATÓRIO: 1194/19D			
OBSERVAÇÃO (OBSERVATION) : -----				
<p>CERTIFICAMOS QUE OS RESULTADOS AQUI ESCRITOS SÃO CORRETOS E QUE AS PEÇAS - TESTE FORAM PREPARADAS , SOLDADAS E ENSAIADAS CONFORME O REQUISITO DA NORMA ASME IX , ED.2017 (WE CERTIFY THAT THE STATEMENTS IN THIS RECORD ARE CORRECT AND THAT THE TEST COUPONS WERE PREPARED , WELDED AND TESTED IN ACCORDANCE WITH THE REQUIREMENTS OF SECTION IX OF THE ASME CODE, ED.2017).</p>				
13/08/2019 DATA (DATE)		 Tiago Furlan Quality Specialist Responsible (By)		

SOLDADOR (WELDER) **José de Lima Proença** SINETE (STAMP): **FQ**
 PROCESSO (PROCESS) : **GTAW** TIPO (TYPE) : **MANUAL**
 E P S N° (WPS Nr) : **J 003 /11** REVISÃO (REVISION) : **4**

VARIÁVEIS (VARIABLES)		DADOS DO TESTE (ACTUAL VALUES)	FAIXA DE QUALIFICAÇÃO (RANGE QUALIFIED)
QW 402	COBRE - JUNTA (BACKING)	SEM (WITHOUT)	SEM / COM (WITHOUT / WITH)
QW 403	ESPECIFICAÇÃO (SPECIFICATION)	ASTM A 106 GR B	-----
MATERIAL	GRUPO P No. (P. NUMBER)	P 1 GR 1	P1 a P15F ; P34 ; P41 a P49
BASE (BASE)	ESPESSURA JUNTA DA TOPO (GROOVE WELD)	3,73 mm	ILIMITADO (UNLIMITED)
METAL (METAL)	(THICKNESS) JUNTA ÂNGULO (FILLET WELD)	NÃO USADO (NOT USED)	ILIMITADO (UNLIMITED)
	DIÂMETRO JUNTA DA TOPO (GROOVE WELD)	1/2" SCH 80	≥ 1/2 "
	(DIAMETER) JUNTA ÂNGULO (FILLET WELD)	NÃO USADO (NOT USED)	ILIMITADO (UNLIMITED)
QW 404	ESPECIFICAÇÃO (SFA)	SFA 5.18	SFA 5.18
METAL DE ADIÇÃO (FILLER METAL)	CLASSIFICAÇÃO (CLASSIFICATION)	ER 70S3	ERXXS-X
	F NUMERO (F Nr)	6	6
	METAL DEPOSITADO (WELD DEPOSITION)	3,73 mm	7,46 mm Max.
	METAL DE ADIÇÃO (FILLER METAL)	COM (WITH)	COM / SEM (WITH / WITHOUT)
	FORMA DO CONSUMÍVEL (FILLER METAL PROD. FORM)	SÓLIDO (SOLID)	SÓLIDO (SOLID)
	INSERTO CONSUMIVEL (CONSUMABLE INSERTS)	NÃO PERMITIDO (NOT PERMIT)	NÃO PERMITIDO (NOT PERMIT)
QW 405	POSIÇÃO (WELD POSITION)	6G	PL. , HOR. , VER. e SC (F, V, H, O)
(POSITION)	PROGRESSÃO (PROGRESSION)	ASCENDENTE (UPHILL)	ANGULO - P, V, H, SC (FILLET - F, V, H, O)
QW 408	TIPO (TYPE)	ARGONIO (ARGON)	-----
GAS (GAS)	PROTEÇÃO NA RAIZ (BACKING GAS)	SEM (WITHOUT)	COM / SEM (WITH / WITHOUT)
QW 409	CORRENTE (CURRENT)	CONTINUA	CONTINUA (CONTINUOUS)
CAR.ELET. (ELECTRICAL CHARACTER.)	POLARIDADE (POLARITY)	DIRETA (DIRECT)	DIRETA (DIRECT)
	MODO DE TRANSFERENCIA (GMAW) (MODE OF METAL TRANSFER.)	NÃO APLICAVEL (NOT APPLICABLE)	NÃO APLICAVEL (NOT APPLICABLE)
QW 360	VARIÁVEIS OPERADOR SOLDAGEM (WELDING VARIABLES OPERATOR)		

QW 191 ENSAIO RADIOGRAFICO (RADIOGRAPHIC TEST) : APROVADO RELATORIO METALTEC 1680C /19

QW 302.4 EXAME VISUAL (VISUAL EXAMINATION) SATISFATÓRIO

(QW 462. 3) ENSAIO DE DOBRAMENTO (BEND TEST)

TIPO DE C.P. (TYPE AND FIGURE)	TIPO IDENTIFICAÇÃO (IDENTIFICATION TYPE)	AValiação DOS CP's (EVALUATION)	RESULTADO (RESULT)
A- TRANSVERSAL (TRANSVERSE)	---	---	---
B- LONGITUDINAL (LONGITUDINAL)	---	---	---
1 - RAIZ (ROOT)	---	---	---
2 - FACE (FACE)	---	---	---
3 - LATERAL (SIDE)	---	---	---

(QW 462. 4) SOLDA DE FILETE (FILLET WELD) : --

TESTE CONDUZIDO POR (TESTS CONDUCTED BY) : **Tiago Furlan**

OBSERVAÇÃO (OBSERVATION) : -----

CERTIFICAMOS QUE OS RESULTADOS AQUI ESCRITOS SÃO CORRETOS E QUE AS PEÇAS - TESTE FORAM PREPARADAS , SOLDADAS E ENSAIADAS CONFORME O REQUISITO DA NORMA ASME IX , ED.2017
 (WE CERTIFY THAT THE STATEMENTS IN THIS RECORD ARE CORRECT AND THAT THE TEST COUPONS WERE PREPARED , WELDED AND TESTED IN ACCORDANCE WITH THE REQUIREMENTS OF SECTION IX OF THE ASME CODE, ED.2017).

20/11/2019
DATA (DATE)

Tiago Furlan
 Responsible Specialist
 Johnson Controls

SOLDADOR (WELDER)	José de Lima Proença	SINETE (STAMP):	FQ
PROCESSO (PROCESS):	GMAW	TIPO (TYPE) :	SEMI-AUTOMÁTICO
EPS Nº (WPS Nr.):	J012/11	REVISÃO (REVISION):	0

VARIÁVEIS (VARIABLES)		DADOS DO TESTE (ACTUAL VALUES)	FAIXA DE QUALIFICAÇÃO (RANGE QUALIFIED)
QW 402	COBRE - JUNTA (BACKING)	SEM (NO)	SEM / COM (WITH OR NO BACKING)
QW 403	ESPECIFICAÇÃO (SPECIFICATION)	SA 516 Gr 70	-----
MATERIAL BASE (BASE METAL)	GRUPO P No. (P. NUMBER)	P1 Gr 1	P1 a P15F ; P34 ; P41 a P49
	ESPESSURA (THICKNESS)	16,0 mm	ILIMITADO (UNLIMITED)
	JUNTA DA TOPO (GROOVE WELD)	NÃO USADO (NOT USED)	NÃO USADO (NOT USED)
	JUNTA ÂNGULO (FILLET WELD)	N. A. (NOT APPLICABLE)	(≥ Ø EXT.73mm) (OUTSIDE Ø 73mm) (≥ Ø EXT.610 mm) (OUTSIDE Ø 610 mm)
DIAMETRO (DIAMETER)	JUNTA DA TOPO (GROOVE WELD)	NÃO USADO (NOT USED)	ILIMITADO (UNLIMITED)
	JUNTA ÂNGULO (FILLET WELD)		
QW 404	ESPECIFICAÇÃO (SFA)	SFA 5.18	SFA 5.18
	CLASSIFICAÇÃO (CLASSIFICATION)	ER70S-6	QW 432
	F NUMERO (F Nr)	6	6
METAL DE ADIÇÃO (FILLER METAL)	FORMA DO CONSUMÍVEL (FILLER MET. PRODUCT FORM)	Sólido (Solid)	Sólido ou Tubular (Solid or Flux Core)
	METAL DEPOSITADO (WELD DEPOSITION)	(> 3 CAMADAS)	TOPO (BUTT) ILIMIT. (UNLIMITED)
	Limitação T [Curto-Circuito] (Limits T [short-Circuiting])	19,0 mm (> 3 LAYERS)	ÂNGULO (FILLET) : ILIMITADO (UNLIMITED)
QW 405	POSIÇÃO (WELD POSITION)	2G 3G	Ø > 610 - P,H,V (Ø > 610 - F,H,V) H-73 ≤ Ø ≤ 610 -P (73 < Ø < 610-F) FILETE - P, V, H (FILLET - F, V, H)
	PROGRESSÃO (PROGRESSION)	ASCENDENTE (UPHILL)	ASCENDENTE (UPHILL)
QW 408	GAS (GAS)	TIPO (TYPE)	CO2 + Argonio (CO2 + Argon)
	PROTEÇÃO NA RAIZ (BACKING GAS)	SEM (WITHOUT)	COM / SEM (WITH / WITHOUT)
QW 409	CORRENTE (CURRENT)	CONTINUA (DIRECT)	CONTINUA (DIRECT)
	POLARIDADE (POLARITY)	INVERSA (REVERSE)	INVERSA (REVERSE)
	MODO DE TRANSFERENCIA (GMAW) (MODE OF METAL TRANSFER. GMAW)	CURTO-CIRCUITO (SHORT-CIRCUIT)	CURTO-CIRCUITO (SHORT-CIRCUIT)
QW 360	CONTROLE VISUAL (DIRECT VISUAL CONTROL)	NÃO APLICAVEL (NOT APPLICABLE)	NÃO APLICAVEL (NOT APPLICABLE)
	CONTROLE AUTOMÁTICO DE VOLTAGEM (AUTOMATIC ARC VOLTAGE CONTROL)	NÃO APLICAVEL (NOT APPLICABLE)	NÃO APLICAVEL (NOT APPLICABLE)
	LOCALIZAÇÃO DA JUNTA (JOINT TRACKING)	NÃO APLICAVEL (NOT APPLICABLE)	NÃO APLICAVEL (NOT APPLICABLE)
	INSERTO CONSUMIVEL (CONSUMABLE INSERTS)	NÃO APLICAVEL (NOT APPLICABLE)	NÃO APLICAVEL (NOT APPLICABLE)
	PROTEÇÃO (BACKING)	NÃO APLICAVEL (NOT APPLICABLE)	NÃO APLICAVEL (NOT APPLICABLE)
	PASSES SIMPLES/MÚLTIPLO (MULTIPLE OR SINGLE PASS)	NÃO APLICAVEL (NOT APPLICABLE)	NÃO APLICAVEL (NOT APPLICABLE)
QW 191	ENSAIO RADIOGRAFICO (RADIOGRAPHIC TEST)	Satisfatório (Satisfactory)	
QW 191.2	ENSAIO ULTRASSOM (ULTRASONIC TEST)	Não Aplicavel (Not Applicable)	
QW 302.4	EXAME VISUAL (VISUAL EXAMINATION)	Aprovado (Approved)	

(QW 462. 3) ENSAIO DE DOBRAMENTO (BEND TEST)

TIPO DE C.P. (TYPE AND FIGURE)	TIPO/IDENTIFICAÇÃO (IDENTIFICATION / TYPE)	AVALIAÇÃO DOS CP's (EVALUATION)	RESULTADO (RESULT)
A- TRANSVERSAL (TRANSVERSE)	---	---	---
B- LONGITUDINAL (LONGITUDINAL)	---	---	---
1 - RAIZ (ROOT)	---	---	---
2 - FACE (FACE)	---	---	---
3 - LATERAL (SIDE)	---	---	---

(QW 462. 4) SOLDA DE FILETE (FILLET WELD) :	Não Aplicavel (Not Applicable)
TESTE CONDUZIDO POR (TESTS CONDUCTED BY) :	Tiago Furlan
TESTE DE LABORATORIO (LABORATORY TEST Nr.) :	METALTEC-EBE RELATÓRIO: 1194/19D
OBSERVAÇÃO (OBSERVATION) : -----	

CERTIFICAMOS QUE OS RESULTADOS AQUI ESCRITOS SÃO CORRETOS E QUE AS PEÇAS - TESTE FORAM PREPARADAS , SOLDADAS E ENSAIADAS CONFORME O REQUISITO DA NORMA ASME IX , ED.2017
(WE CERTIFY THAT THE STATEMENTS IN THIS RECORD ARE CORRECT AND THAT THE TEST COUPONS WERE PREPARED , WELDED AND TESTED IN ACCORDANCE WITH THE REQUIREMENTS OF SECTION IX OF THE ASME CODE, ED.2017).

Tiago Furlan
 Quality Specialist
 Johnson Controls
 Responsável (By)

13/08/2019
 DATA (DATE)

SOLDADOR (WELDER) **JAIRO PEDRO GUERRA** SINETE (STAMP) : **MV**
 PROCESSO (PROCESS) : **GMAW** TIPO (TYPE) : **SEMI-AUTOMÁTICO**
 E P S N° (WPS Nr) : **J 012 /11** REVISÃO (REVISION) : **3**

VARIÁVEIS (VARIABLES)		DADOS DO TESTE (ACTUAL VALUES)	FAIXA DE QUALIFICAÇÃO (RANGE QUALIFIED)
QW 402	COBRE - JUNTA (BACKING)	SEM (NO)	SEM / COM (WITH OR NO BACKING)
QW 403 MATERIAL BASE (BASE METAL)	ESPECIFICAÇÃO (SPECIFICATION)	SA 516 Gr 70 x SA 516 Gr 70	-----
	GRUPO P No. (P. NUMBER)	P1 Gr 1 x P1 Gr 1	P1 a P15F ; P34 ; P41 a P49
	ESPESSURA (THICKNESS)	12,5 mm	25,0 mm
	JUNTA DA TOPO (GROOVE WELD)	NÃO USADO (NOT USED)	NÃO USADO (NOT USED)
	JUNTA ÂNGULO (FILLET WELD)	N. A. (NOT APPLICABLE)	(≥ Ø EXT.73mm) (OUTSIDE Ø 73mm)
DIAMETRO (DIAMETER)	JUNTA DA TOPO (GROOVE WELD)	NÃO USADO (NOT USED)	(≥ Ø EXT.610 mm) (OUTSIDE Ø 610 mm)
	JUNTA ÂNGULO (FILLET WELD)	NÃO USADO (NOT USED)	ILIMITADO (UNLIMITED)
QW 404 METAL DE ADIÇÃO (FILLER METAL)	ESPECIFICAÇÃO (SFA)	SFA 5.18	SFA 5.18
	CLASSIFICAÇÃO (CLASSIFICATION)	ER 70S6	QW 432
	F NUMERO (F Nr)	6	6
FORMA DO CONSUMÍVEL (FILLER MET. PRODUCT FORM)	SÓLIDO (SOLID)	SÓLIDO OU TUBULAR (SOLID OR FLUX CORED)	
METAL DEPOSITADO (WELD DEPOSITION)	12,5 mm (> 3 CAMADAS) (> 3 LAYERS)	TOPO (BUTT) ILIMIT. (UNLIMITED)	ÂNGULO (FILLET) : ILIMITADO (UNLIMITED)
QW 405 POSIÇÃO (POSITION)	PROGRESSÃO (PROGRESSION)	3G	Ø > 610 - P,V (Ø > 610 - F,V) 73 ≤ Ø ≤ 610 - P (73 < Ø < 610 - F) FILETE - P, V, H (FILLET - F, V, H)
		ASCENDENTE (UPHILL)	ASCENDENTE (UPHILL)
QW 408 GAS (GAS)	TIPO (TYPE)	CO2 + Argonio (CO2 + Argon)	CO2 + Argonio (CO2 + Argon)
	PROTEÇÃO NA RAIZ (BACKING GAS)	SEM (WITHOUT)	COM / SEM (WITH / WITHOUT)
QW 409 CAR.ELET. (ELECTRICAL CHARACTER.)	CORRENTE (CURRENT)	CONTINUA (DIRECT)	CONTINUA (DIRECT)
	POLARIDADE (POLARITY)	INVERSA (REVERSE)	INVERSA (REVERSE)
	MODO DE TRANSFERENCIA (GMAW) (MODE OF METAL TRANSFER. GMAW)	CURTO-CIRCUITO (SHORT-CIRCUIT)	CURTO-CIRCUITO (SHORT-CIRCUIT)
QW 360 VARIÁVEIS OPERADOR SOLDAGEM (WELDING VARIABLES OPERATOR)	CONTROLE VISUAL (DIRECT VISUAL CONTROL)	NÃO APLICAVEL (NOT APPLICABLE)	NÃO APLICAVEL (NOT APPLICABLE)
	CONTROLE AUTOMÁTICO DE VOLTAGEM (AUTOMATIC ARC VOLTAGE CONTROL)	NÃO APLICAVEL (NOT APPLICABLE)	NÃO APLICAVEL (NOT APPLICABLE)
	LOCALIZAÇÃO DA JUNTA (JOINT TRACKING)	NÃO APLICAVEL (NOT APPLICABLE)	NÃO APLICAVEL (NOT APPLICABLE)
	INSERTO CONSUMIVEL (CONSUMABLE INSERTS)	NÃO APLICAVEL (NOT APPLICABLE)	NÃO APLICAVEL (NOT APPLICABLE)
	PROTEÇÃO (BACKING)	NÃO APLICAVEL (NOT APPLICABLE)	NÃO APLICAVEL (NOT APPLICABLE)
	PASSES SIMPLES/MULTIPLÔ (MULTIPLE OR SINGLE PASS)	NÃO APLICAVEL (NOT APPLICABLE)	NÃO APLICAVEL (NOT APPLICABLE)
QW 191	ENSAIO RADIOGRAFICO (RADIOGRAPHIC TEST)	NÃO APLICAVEL (NOT APPLICABLE)	
QW 191.2	ENSAIO ULTRASOM (ULTRASONIC TEST)	NÃO APLICAVEL (NOT APPLICABLE)	
QW 302.4	EXAME VISUAL (VISUAL EXAMINATION)	APROVADO (APPROVED)	

(QW 462. 3) ENSAIO DE DOBRAMENTO (BEND TEST)

TIPO DE C.P. (TYPE AND FIGURE)	TIPO/IDENTIFICAÇÃO (IDENTIFICATION/TYPE)	AVALIAÇÃO DOS CP's (EVALUATION)	RESULTADO (RESULT)
A- TRANSVERSAL (TRANSVERSE)	A3 DL1 (SIDE BEND)	DESCONTINUIDADE = 1,0 mm (DISCONTINUITYS = 1,0mm)	APROVADO (APPROVED)
B- LONGITUDINAL (LONGITUDINAL)	A3 DL2 (SIDE BEND)	DESCONTINUIDADE = 1,8 mm (DISCONTINUITYS = 1,8mm)	APROVADO (APPROVED)
1 - RAIZ (ROOT)			
2 - FACE (FACE)			
3 - LATERAL (SIDE)	---	---	---

(**QW 462. 4**) SOLDA DE FILETE (FILLET WELD) : NÃO APLICAVEL (NOT APPLICABLE)
 TESTE CONDUZIDO POR (TESTS CONDUCTED BY) : RUBENS ANTONO FILHO
 TESTE DE LABORATORIO (LABORATORY TEST Nr.) : TORK REL. DE ENSAIO Nº 17102093MCSP
 OBSERVAÇÃO (OBSERVATION) : -----

CERTIFICAMOS QUE OS RESULTADOS AQUI ESCRITOS SÃO CORRETOS E QUE AS PEÇAS - TESTE FORAM PREPARADAS , SOLDADAS E ENSAIADAS CONFORME O REQUISITO DA NORMA ASME IX , ED.2015
 (WE CERTIFY THAT THE STATEMENTS IN THIS RECORD ARE CORRECT AND THAT THE TEST COUPONS WERE PREPARED , WELDED AND TESTED IN ACCORDANCE WITH THE REQUIREMENTS OF SECTION IX OF THE ASME CODE, ED.2015).

 09/10/2017
 DATA (DATE)



Rubens Antonio Filho
 CREA 218736/D
 TECNÓLOGO EM MECÂNICA ESPECIALIDADE SOLDAGEM

CONTROLE DE QUALIDADE

Johnson Controls		REGISTRO DE QUALIFICAÇÃO DE SOLDADOR / OPERADOR (WELDER OR WELDING OPERATOR QUALIFICATION TEST)		N° RQ 228	
				PAG. (PAGE) 1/1	
SOLDADOR (WELDER) JAIRO PEDRO GUERRA		SINETE (STAMP): MV			
PROCESSO (PROCESS): SAW		TIPO (TYPE): AUTOMÁTICO			
E P S N° (WPS Nr): SB 017/00		REVISÃO (REVISION): 3			
VARIÁVEIS (VARIABLES)		DADOS DO TESTE (ACTUAL VALUES)	FAIXA DE QUALIFICAÇÃO (RANGE QUALIFIED)		
QW 402	COBRE - JUNTA (BACKING)	COM (WITH)	COM (WITH)		
QW 403	ESPECIFICAÇÃO (SPECIFICATION)	SA 516 Gr 70 x SA 516 Gr 70	-----		
MATERIAL BASE (BASE METAL)	GRUPO P No. (P. NUMBER)	P 1 Gr 1 x P1 Gr 1	P1 a P11 ; P34 ; P41 a P49		
	ESPESSURA (THICKNESS)	19,0 mm	ILIMITADO (UNLIMITED)		
	JUNTA DA TOPO (GROOVE WELD) JUNTA ÂNGULO (FILLET WELD)	NÃO USADO (NOT USED)	NÃO USADO (NOT USED)		
	JUNTA DA TOPO (GROOVE WELD) JUNTA ÂNGULO (FILLET WELD)	NÃO USADO (NOT USED)	(≥ Ø EXT.73mm)(OUTSIDE Ø 73mm) (≥ Ø EXT.610 mm)(OUTSIDE Ø 610 mm)		
QW 404	ESPECIFICAÇÃO (SFA) CLASSIFICAÇÃO (CLASSIFICATION) F NUMERO (F Nr) METAL DEPOSITADO (WELD DEPOSITION)	SFA 5.17 F 7A4 EM12K 6 16,0 mm	SFA 5.17 QW 432 6 TOPO (BUTT) 32 mm Max. ÂNGULO (FILLET) ILIMIT. (UNLIMITED)		
QW 405	POSIÇÃO (WELD POSITION) PROGRESSÃO (PROGRESSION)	1G NÃO APLICAVEL (NOT APPLICABLE)	1 G / 1 F NÃO APLICAVEL (NOT APPLICABLE)		
QW 408	GAS (GAS) TIPO (TYPE) PROTEÇÃO NA RAIZ (BACKING GAS)	CO2 + Ar (CO2 + Ar.) NÃO APLICAVEL (NOT APPLICABLE)	CO2 + Ar. (CO2 + Ar.) NÃO APLICAVEL (NOT APPLICABLE)		
QW 409	CORRENTE (CURRENT) CAR.ELET. (ELECTRICAL CHARACTER.) POLARIDADE (POLARITY) MODO DE TRANSFERENCIA (GMAW) (MODE OF METAL TRANSFER.)	CONTINUA (DIRECT) INVERSA (REVERSE) NÃO APLICAVEL (NOT APPLICABLE)	CONTINUA (DIRECT) INVERSA (REVERSE) NÃO APLICAVEL (NOT APPLICABLE)		
QW 360	CONTROLE VISUAL (DIRECT VISUAL CONTROL) VARIÁVEIS OPERADOR (AUTOMATIC ARC VOLTAGE CONTROL) SOLDAGEM (WELDING) LOCALIZAÇÃO DA JUNTA (JOINT TRACKING) VAABLES OPERATOR (WELDING) INSERTO CONSUMIVEL (CONSUMABLE INSERTS) PROTEÇÃO (BACKING) PASSSES SIMPLE /MULTIPLO (MULTIPLE OR SIMPLE PASS)	DIRETO (DIRECT) NÃO APLICAVEL (NOT APPLICABLE) NÃO APLICAVEL (NOT APPLICABLE) MANUAL NÃO APLICAVEL (NOT APPLICABLE) COM (WITH) MULTIPLoS (MULTIPLE)	DIRETO (DIRECT) NÃO APLICAVEL (NOT APPLICABLE) NÃO APLICAVEL (NOT APPLICABLE) MANUAL NÃO APLICAVEL (NOT APPLICABLE) COM (WITH) MULTIPLoS (MULTIPLE)		
QW 191	ENSAIO RADIOGRAFICO (RADIOGRAPHIC TEST)	NÃO APLICADO (NOT USED)			
QW 302.4	EXAME VISUAL (VISUAL EXAMINATION)	APROVADO (APPROVED)			
(QW 462. 3) ENSAIO DE DOBRAMENTO (BEND TEST)					
TIPO DE C.P. (TYPE AND FIGURE)	TIPO/IDENTIFICAÇÃO (IDENTIFICATION / TYPE)	AVALIAÇÃO DOS CP's (EVALUATION)		RESULTADO (RESULT)	
A- TRANSVERSAL (TRANSVERSE)	---	---		---	
B- LONGITUDINAL (LONGITUDINAL)	---	---		---	
1 - RAIZ (ROOT)	---	---		---	
2 - FACE (FACE)	---	---		---	
3 - LATERAL (SIDE)	---	---		---	
(QW 462. 4) SOLDA DE FILETE (FILLET WELD) :		NÃO APLICAVEL (NOT APPLICABLE)			
TESTE CONDUZIDO POR (TESTS CONDUCTED BY) :		RUBENS ANTONIO FILHO			
TESTE DE LABORATÓRIO (LABORATORY TEST Nr.) :		APROVADO RELAT. METALTEC 982-2017			
CERTIFICAMOS QUE OS RESULTADOS AQUI ESCRITOS SÃO CORRETOS E QUE AS PEÇAS - TESTE FORAM PREPARADAS , SOLDADAS E ENSAIADAS CONFORME O REQUISITO DA NORMA ASME IX , ED.2015 (WE CERTIFY THAT THE STATEMENTS IN THIS RECORD ARE CORRECT AND THAT THE TEST COUPONS WERE PREPARED , WELDED AND TESTED IN ACCORDANCE WITH THE REQUIREMENTS OF SECTION IX OF THE ASME CODE, ED. 2015).					
17/10/2017 DATA (DATE)		 Rubens Antonio Filho CREA 218739/D TECNÓLOGO EM MECÂNICA MODALIDADE SOLDAG CONTROLE DE QUALIDADE			



5) RELATÓRIOS DE INSPEÇÃO / TESTES
TESTS REPORTS

CLIENTE:	MARFRIG GLOBAL FOODS S.A.	PEDIDO:	74187
EQUIPAMENTO:	UNIDADE COMPRESSORA PARAFUSO RWF 399	OBRA:	M1014308
Nº SÉRIE:	322102	TAG:	N/A
P.I.:	E-32107D.026-01	PINTURA:	VERDE FRICK
DESENHO:	4847CF399-032	REFRIGERANTE:	R717
COMPRESSOR:	SGC 2817	PESO:	5818KG
SÉRIE:	11552F12058773	MATERIAL:	N/A
SEPARADOR ÓLEO:	367259 - SO7664	VÁLVULAS:	179614, 179615
FILTRO ÓLEO:	391218 - FO1149 / 391219 - FO1150	MANO VAC:	125652, 125789, 125795
SEPARADOR LIQUIDO:	N/A	TRANSDUTOR:	OK
RETIFICADOR ÓLEO:	N/A	PT100:	OK
TROCADOR:	VAHTERUS 61132	MOTOR:	31AGO21 - 1061829239
SISTEMA CONTROLE:	QUANTUM 220V	DATA:	30/09/2021

PONTOS DE INSPEÇÃO

FASE I	15%	OK	NOK	N/A		OK	NOK	N/A
Desenhos	<input checked="" type="checkbox"/>	<input type="checkbox"/>	<input type="checkbox"/>	<input type="checkbox"/>	Linhas posição correta sem danos	<input checked="" type="checkbox"/>	<input type="checkbox"/>	<input type="checkbox"/>
Fluxograma	<input checked="" type="checkbox"/>	<input type="checkbox"/>	<input type="checkbox"/>	<input type="checkbox"/>	Válvulas posição correta sem danos	<input checked="" type="checkbox"/>	<input type="checkbox"/>	<input type="checkbox"/>
Estrutura	<input checked="" type="checkbox"/>	<input type="checkbox"/>	<input type="checkbox"/>	<input type="checkbox"/>	Manômetros indicando posição + (1kg)	<input checked="" type="checkbox"/>	<input type="checkbox"/>	<input type="checkbox"/>
Memorial Cálculo	<input checked="" type="checkbox"/>	<input type="checkbox"/>	<input type="checkbox"/>	<input type="checkbox"/>	Adesivos aplicado nos locais correto	<input checked="" type="checkbox"/>	<input type="checkbox"/>	<input type="checkbox"/>
Desenho Plaqueta	<input checked="" type="checkbox"/>	<input type="checkbox"/>	<input type="checkbox"/>	<input type="checkbox"/>	Parafusos torquados / apertados	<input checked="" type="checkbox"/>	<input type="checkbox"/>	<input type="checkbox"/>
EER	<input checked="" type="checkbox"/>	<input type="checkbox"/>	<input type="checkbox"/>	<input type="checkbox"/>	Plaquetas fixadas nos locais corretos	<input checked="" type="checkbox"/>	<input type="checkbox"/>	<input type="checkbox"/>
Ata Handover	<input checked="" type="checkbox"/>	<input type="checkbox"/>	<input type="checkbox"/>	<input type="checkbox"/>	Itens avulsos identificados	<input type="checkbox"/>	<input type="checkbox"/>	<input checked="" type="checkbox"/>
Selecionamento Sabroe / Frick	<input checked="" type="checkbox"/>	<input type="checkbox"/>	<input type="checkbox"/>	<input type="checkbox"/>	Bobinas e resistência na posição correta	<input checked="" type="checkbox"/>	<input type="checkbox"/>	<input type="checkbox"/>
FASE II	22%	OK	NOK	N/A		OK	NOK	N/A
Relatório Alinhamento motor	<input checked="" type="checkbox"/>	<input type="checkbox"/>	<input type="checkbox"/>	<input type="checkbox"/>	Visores limpos e sem trincas	<input checked="" type="checkbox"/>	<input type="checkbox"/>	<input type="checkbox"/>
Relatório Estanqueidade	<input checked="" type="checkbox"/>	<input type="checkbox"/>	<input type="checkbox"/>	<input type="checkbox"/>	Isolamento térmico sem deformações	<input type="checkbox"/>	<input type="checkbox"/>	<input checked="" type="checkbox"/>
Relatório Pintura	<input checked="" type="checkbox"/>	<input type="checkbox"/>	<input type="checkbox"/>	<input type="checkbox"/>	Kit coleta óleo montado local correto	<input checked="" type="checkbox"/>	<input type="checkbox"/>	<input type="checkbox"/>
Relatório Elétrica	<input checked="" type="checkbox"/>	<input type="checkbox"/>	<input type="checkbox"/>	<input type="checkbox"/>	Cabeamento elétrico correto	<input checked="" type="checkbox"/>	<input type="checkbox"/>	<input type="checkbox"/>
Verificar Montagem	<input checked="" type="checkbox"/>	<input type="checkbox"/>	<input type="checkbox"/>	<input type="checkbox"/>	Conectores elétricos apertados sem folga	<input checked="" type="checkbox"/>	<input type="checkbox"/>	<input type="checkbox"/>
Desenhos e Fluxograma	<input checked="" type="checkbox"/>	<input type="checkbox"/>	<input type="checkbox"/>	<input type="checkbox"/>	Válvulas bloqueio devidamente fechadas	<input checked="" type="checkbox"/>	<input type="checkbox"/>	<input type="checkbox"/>
Fotos Quantum / Unisab	<input checked="" type="checkbox"/>	<input type="checkbox"/>	<input type="checkbox"/>	<input type="checkbox"/>	Volantes e capacetes montados e pintados	<input checked="" type="checkbox"/>	<input type="checkbox"/>	<input type="checkbox"/>
Validar Plaquetas	<input checked="" type="checkbox"/>	<input type="checkbox"/>	<input type="checkbox"/>	<input type="checkbox"/>	Cordões solda sem respingo e carepa	<input checked="" type="checkbox"/>	<input type="checkbox"/>	<input type="checkbox"/>
Atualização Estrutura	<input type="checkbox"/>	<input type="checkbox"/>	<input type="checkbox"/>	<input checked="" type="checkbox"/>	Equipamento sem cantos vivos e rebarbas	<input checked="" type="checkbox"/>	<input type="checkbox"/>	<input type="checkbox"/>
Fotos Acessórios	<input type="checkbox"/>	<input type="checkbox"/>	<input type="checkbox"/>	<input checked="" type="checkbox"/>	Superfície sem marcas de lixadeira	<input checked="" type="checkbox"/>	<input type="checkbox"/>	<input type="checkbox"/>
Liberção Escopo	<input checked="" type="checkbox"/>	<input type="checkbox"/>	<input type="checkbox"/>	<input type="checkbox"/>	Área vedação sem respingos óleo	<input checked="" type="checkbox"/>	<input type="checkbox"/>	<input type="checkbox"/>
Traveler	<input checked="" type="checkbox"/>	<input type="checkbox"/>	<input type="checkbox"/>	<input type="checkbox"/>	Tags montados corretamente	<input type="checkbox"/>	<input type="checkbox"/>	<input checked="" type="checkbox"/>
FASE III	64%	OK	NOK	N/A		OK	NOK	N/A
Equipamento Transferido CQ	<input checked="" type="checkbox"/>	<input type="checkbox"/>	<input type="checkbox"/>	<input type="checkbox"/>	Painel elétrico portas alinhadas	<input type="checkbox"/>	<input type="checkbox"/>	<input checked="" type="checkbox"/>
Equipamento limpo	<input checked="" type="checkbox"/>	<input type="checkbox"/>	<input type="checkbox"/>	<input type="checkbox"/>	Painel elétrico fixado corretamente	<input type="checkbox"/>	<input type="checkbox"/>	<input checked="" type="checkbox"/>
Pintura sem resíduos, riscos e borões	<input checked="" type="checkbox"/>	<input type="checkbox"/>	<input type="checkbox"/>	<input type="checkbox"/>	Defensa pintada cor amarela	<input checked="" type="checkbox"/>	<input type="checkbox"/>	<input type="checkbox"/>
Pintura sem tonalidades distintas	<input checked="" type="checkbox"/>	<input type="checkbox"/>	<input type="checkbox"/>	<input type="checkbox"/>	Defensa montada corretamente	<input checked="" type="checkbox"/>	<input type="checkbox"/>	<input type="checkbox"/>
Setas de fluxo estão pintados	<input checked="" type="checkbox"/>	<input type="checkbox"/>	<input type="checkbox"/>	<input type="checkbox"/>	Preencher Etiqueta	<input checked="" type="checkbox"/>	<input type="checkbox"/>	<input type="checkbox"/>
Símbolos estão pintados	<input checked="" type="checkbox"/>	<input type="checkbox"/>	<input type="checkbox"/>	<input type="checkbox"/>	Enviar liberação e tirar CQ	<input checked="" type="checkbox"/>	<input type="checkbox"/>	<input type="checkbox"/>
Sensores posição correta sem danos	<input checked="" type="checkbox"/>	<input type="checkbox"/>	<input type="checkbox"/>	<input type="checkbox"/>	Colar Etiqueta Equipamento	<input checked="" type="checkbox"/>	<input type="checkbox"/>	<input type="checkbox"/>
					Concluir planilha liberação	<input checked="" type="checkbox"/>	<input type="checkbox"/>	<input type="checkbox"/>

OBSERVAÇÕES - ESCOPO

01 CJ 9712+985-POR	MANUAL COMPR.PARAF.PORTUGUES
01 CJ 3447C1054	KIT TERMOENCOLHIVEL PARA RXF/RWF
01 CJ 531B0100H03KS	ELEM FIL OL DE 6" X 43 5/16"
01 CJ 2112C008S	CHU TP "J" M24X400

RESULTADO FINAL

EQUIPAMENTO LIBERADO SEM PENDÊNCIAS	<input type="checkbox"/>	STATUS	100%
EQUIPAMENTO LIBERADO COM PENDÊNCIAS	<input checked="" type="checkbox"/>		

LIBERADO POR: _____ JAIME SILVA
ANALISTA QUALIDADE
ASSINATURA: _____ *JAIME SILVA*



RELATÓRIO DE TESTE E VÁCUO UNIDADE
(REPORT OF TEST AND VACUOUS OF UNIT)

No.(Nr.):

FOLHA (LEAF): 1 DE 1

CLIENTE (CUSTOMER): MARFRIG GLOBAL FOODS	DATA (DATE): 26/09/2021
EQUIPAMENTO (EQUIPMENT): UNIDADE COMPRESSORA	P.I. - ITEM (PART - SALE ORDER): E-32107D.026-01
MODELO (MODEL) / ORDEM PRODUÇÃO RWF II 399/QUANTM/1014298	SÉRIE (SERIAL Nr.): 322102

TESTE PNEUMÁTICO
(PNEUMATIC TEST)

TESTE HIDROSTÁTICO
(HYDROSTATIC TEST)

TESTE DE RESISTÊNCIA (RESISTANCE TEST)

	GAS		PRESSÃO / bar (PRESSURE / bar)	DURAÇÃO (TIME)	RESULTADO (RESULT)
	N2	AR (AIR)			
UNIDADE (UNIT)		✓	21	30 SEG	OK

MANÔMETRO UTILIZADO (MANOMETER USED): MA 145 MA 130

OBSERVAÇÃO (OBSERVATION): SIM NÃO

TESTE DE ESTANQUEIDADE (LEAK TEST)

	GAS			PRESSÃO / bar (PRESSURE / bar)	DURAÇÃO (TIME)	RESULTADO (RESULT)
	N2	R22	AR (AIR)			
UNIDADE (UNIT)			✓	18	1:00 H	OK
UNIDADE (UNIT)	✓	✓		12.5	30 min	OK

MANÔMETRO UTILIZADO (MANOMETER USED):

OBSERVAÇÃO : REALIZADO TESTE DE ESTANQUEIDADE COM ESPUMA DE SABÃO
(THE LEAK TEST WAS REALIZED WITH SOAP FOAM)

(OBSERVATION) TESTE REALIZADO COM DETECTOR ELETRÔNICO DE VAZAMENTOS
MODELO: INFICON D - TEK 15
(THE TEST WAS REALIZED WITH LEAK ELETRONIC DETECTOR MODEL:
INFICON D - TEK 15)

TESTE VÁCUO (VACUOUS TEST)

DATA (DATE): 26/09/2021	INÍCIO (BEGINNING): 15:00	1° LEITURA (READING): 1970
DATA (DATE): 26/09/2021	TERMINO (FINISH): 16:00	2° LEITURA (READING): 1970
VARIÇÃO DOS MICRONS DEPOIS DE 1/2 HORA DE ESPERA (VARIATION OF MICRONS AFTER 01 HOUR OF WAIT)		0 µmHg
UNIDADE PRESSURIZADA PRESSÃO ATMOSFÉRICA OU MAIS (UNIT PRESSURIZED PRESSURE ATMOSPHERIC OR MORE)		1 BAR N°

TESTE REALIZADO COM VACUÔMETRO DIGITAL IBRACON MODELO: NPI-P / VC-01
THE TEST WAS REALIZED WITH VACUÔMETRO DIGITAL IBRACON MODEL: NPI-P / VC-01

OPERADOR (OPERATOR)

Sueli Moraes
Quality Analyst
Johnson Controls
INSPEÇÃO (INSPECTOR)

CLIENTE (CLIENT)



RELATÓRIO DE TESTE TEST REPORT

No. (Nr.):

507663/2021

CLIENTE (CUSTOMER): MARFRIG GLOBAL FOODS S.A	O.P. (PRODUCTION ORDER)/DRAWING 1013974/548E0406G31BR	
EQUIPAMENTO (EQUIPMENT): SEPARADOR DE OLEO	P.I. (SALE ORDER): E-32107D.026-02	DATA (DATE): 06/09/2021
HOS-36,21BAR,RWF316/399		367258

TIPO DE TESTE (TYPE TEST)

 TESTE PNEUMÁTICO
(PNEUMATIC TEST) TESTE HIDROSTÁTICO
(HYDROSTATIC TEST)

TESTE DE RESISTÊNCIA (RESISTANCE TEST)

	GAS		PRESSÃO / bar (PRESSURE / bar)	DURAÇÃO (TIME)	RESULTADO (RESULT)
	N2	AR (AIR)			
CORPO / CASCO (SHELL)		✓	23,5	30 SEG	OK
CABEÇOTES (HEAD)					
SERPENTINAS (SERPENTIN)					

MANÔMETRO UTILIZADO (MANOMETER USED): MA 140 MA 136

OBSERVAÇÃO (OBSERVATION): OCORREU VAZAMENTO SIM NÃO

TESTE DE ESTANQUEIDADE (LEAK TEST)

	GAS			PRESSÃO / bar (PRESSURE / bar)	DURAÇÃO (TIME)	RESULTADO (RESULT)
	N2	R22	AR (AIR)			
CORPO / CASCO (SHELL)			✓	2L	30 MIN	OK
CABEÇOTES (HEAD)						
SERPENTINAS (SERPENTIN)						

MANÔMETRO UTILIZADO (MANOMETER USED): MA 140 MA 136

OBSERVAÇÃO : REALIZADO TESTE DE ESTANQUEIDADE COM ESPUMA DE SABÃO
(THE LEAK TEST WAS REALIZED WITH SOAP FOAM)

TESTE REALIZADO COM DETECTOR ELETRÔNICO DE VAZAMENTOS
MODELO: INFICON D - TEK 15
(THE TEST WAS REALIZED WITH LEAK ELETRONIC DETECTOR MODEL:
INFICON D - TEK 15)

OBSERVAÇÃO GERAL (REMARKS)

Tiago Furtan
Quality specialist
Johnson Controls
30/09/21Sueli Moraes
Quality Analyst
Johnson Controls
OPERADOR (OPERATOR)

INSPECTOR (INSPECTOR)

CLIENTE (CLIENT)

		RELATÓRIO DE ENSAIO POR LÍQUIDO PENETRANTE LIQUID PENETRANT EXAMINATION REPORT		Nº SO7663/21TF PAGE: 1 / 1
CLIENTE / CLIENT MARFRIG	PEDIDO / SALES ORDER 36107D026	FORNECEDOR / SUPPLIER N/A	DATA / DATE SEPT 6, 2021	
EQUIPAMENTO / EQUIPMENT SEPARADOR DE OLEO HOS 36	DES. / ITEM / DRAWING 548E0406G31BR	MATERIAL/ESPESSURA MATERIAL / THICKNESS SA 516 GR 70 # 12,5 mm	TECNICA / TECHNIQUE II A	
CODIGO DE REFERENCIA REFERENCE CODE ASME Sec. V - Artigo 6	CRITERIO DE ACEITAÇÃO ACCEPTANCE STANDARD ASME Sec.VIII-Div.1-Ap. 8	CONDIÇÃO DA SUPERFÍCIE SURFACE CONDITION ESCOVADA	PRODUTO DE LIMPEZA CLEANING PRODUCT SOLVENTE	
EQUIPAMENTO DE ILUMINAÇÃO / LIGHTING EQUIPMENT Iluminação Natural do Setor com Auxílio de Lanterna LED 1.100.000 Lumens / Natural Lighting Sector Assists with Flashlight LED 1.100.000 Lumens		PROCEDIMENTO REV / PROCEDURE REVISION BOS-17.00.283.BE.BR- Rv.03		
MARCA E TIPO DO PENETRANTE: MARK AND TYPE OF PENETRANT <input checked="" type="checkbox"/> Visível / Visible <input type="checkbox"/> Fluorescente / Fluorescent	METAL CHEK VP 30	MARCA E TIPO DO REVELADOR: MARK AND TYPE OF DEVELOPER <input checked="" type="checkbox"/> Aquoso / Aqueous <input type="checkbox"/> Não Aquoso / Non Aqueous	METAL CHEK DL 70	TIPO DO REMOVEDOR TYPE OF REMOVER AGUA

MAPA E REGISTROS DAS INDICAÇÕES / MAP AND RECORD OF INDICATIONS



ENSAIO APLICADO NAS SOLDAS: / TEST USED IN WELDING:

- 1) JUNTAS CIRCUNFERENCIAIS / CIRCUMFERENCIAL JOINTS: C1, C2 e C3
- 2) JUNTA LONGITUDINAL / LONGITUDINAL JOINT: L1 e L2.
- 3) SELAS, SUPPORTS / SADDLES, SUPPORTS: S.
- 4) BOCA DE VISITA / INSPECTION HOLE: BV.
- 5) BOCAIS / NOZZLES: W.
- 6) BATOQUE / SPIN HOLE: B2.
- 7) STIL CHAMBER: SC
- 8) JUNTA DE CANTO WT (Testado bisel antes da solda)

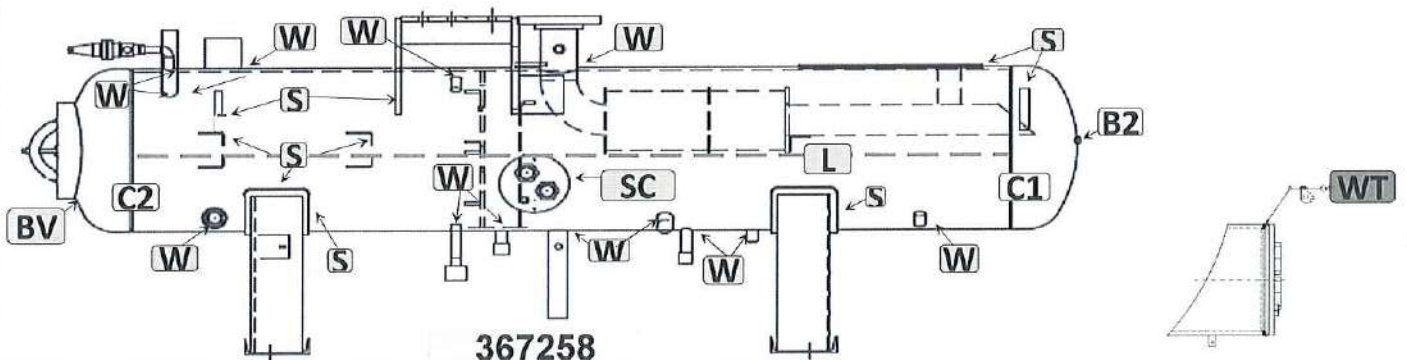

OUTROS INSTRUMENTOS USADOS / OTHERS INSTRUMENTS USED

- 1 - Luxímetro Digital / Digital Lux Meter: Minipa MLM-1011 (LUX-01)
- 2 - Termômetro Infravermelho Portátil / Portable Infrared Thermometer: Minitemp Raytec MT4 (Não Controlado)

TIPO DA INDICAÇÃO / TYPE OF INDICATION	RESULTADOS / RESULTS
FF - FALTA DE FUSÃO / LACK OF FUSION MO - MORDEDURA / UNDERCUT DL - DUPLA LAMINAÇÃO / LAMINATION PO - PORO / GAS PORE OV - SOBREPOSIÇÃO / OVERLAP TL - TRINCA LONGITUDINAL / LONGITUDINAL CRACK TR - TRINCA TRANSVERSAL / TRANSVERSE CRACK L-LINEAR - AR-ARREDONDADA / ROUNDED	A - APROVADO / APPROVED R - REPROVADO / REJECTED EC - EXAME COMPLEMENTAR / COMPLEMENT EXAM

Johnson Controls BE do Brasil Ltda Inspetor / Examiner TIAGO FURLAN Inspetor LP Nível II SNT TC 1; 21 06/21	AUTHORIZED INSPECTOR	CLIENTE / CLIENT
--	-----------------------------	-------------------------



RELATÓRIO DE TESTE TEST REPORT

No. (Nr.):

FOU 48/2024

CLIENTE (CUSTOMER): MARFRIG BATAGUASSU	O.P. (PRODUCTION ORDER)/DRAWING 1013994/553E0014G02BR	
EQUIPAMENTO (EQUIPMENT): FILTRO OLEO	P.I. (SALE ORDER): E-32107D.026-02	DATA (DATE): 14/09/2024
FO-CX2.1/2 POL		391216

TIPO DE TESTE (TYPE TEST)

 TESTE PNEUMÁTICO
(PNEUMATIC TEST) TESTE HIDROSTÁTICO
(HYDROSTATIC TEST)

TESTE DE RESISTÊNCIA (RESISTANCE TEST)

	GAS		PRESSÃO / bar (PRESSURE / bar)	DURAÇÃO (TIME)	RESULTADO (RESULT)
	N2	AR (AIR)			
CORPO / CASCO (SHELL)		x	32	30 SEG	OK
CABEÇOTES (HEAD)					
SERPENTINAS (SERPENTIN)					

MANÔMETRO UTILIZADO (MANOMETER USED): MA 145 MA 136

OBSERVAÇÃO (OBSERVATION): OCORREU VAZAMENTO SIM NÃO

TESTE DE ESTANQUEIDADE (LEAK TEST)

	GAS			PRESSÃO / bar (PRESSURE / bar)	DURAÇÃO (TIME)	RESULTADO (RESULT)
	N2	R22	AR (AIR)			
CORPO / CASCO (SHELL)			x	28	30 min	OK
CABEÇOTES (HEAD)						
SERPENTINAS (SERPENTIN)						

MANÔMETRO UTILIZADO (MANOMETER USED): MA 145 MA 136

OBSERVAÇÃO : REALIZADO TESTE DE ESTANQUEIDADE COM ESPUMA DE SABÃO
(THE LEAK TEST WAS REALIZED WITH SOAP FOAM)

(OBSERVATION) TESTE REALIZADO COM DETECTOR ELETRÔNICO DE VAZAMENTOS
MODELO: INFICON D - TEK 15
(THE TEST WAS REALIZED WITH LEAK ELETRONIC DETECTOR MODEL:
INFICON D - TEK 15)

OBSERVAÇÃO GERAL (REMARKS)

Tiago Furlan
Quality Specialist
Johnson ControlsSueli Moraes
Quality Analyst
Johnson Controls
INSPEÇÃO (INSPECTOR)

OPERADOR (OPERATOR)

CLIENTE (CLIENT)

		RELATÓRIO DE ENSAIO POR LÍQUIDO PENETRANTE LIQUID PENETRANT EXAMINATION REPORT		N° FO1148/21TF PAGE: 1 / 1
CLIENTE / CLIENT MARFRIG	PEDIDO / SALES ORDER 32107D026	FORNECEDOR / SUPPLIER NA	DATA / DATE SEPT 14, 2021	
EQUIPAMENTO / EQUIPMENT FILTRO DE OLEO FO43DN73	DES. / ITEM / DRAWING 553E0014BR	MATERIAL/ESPESSURA MATERIAL / THICKNESS SA 106 B / 8" SCH40	TÉCNICA / TECHNIQUE II A	
CÓDIGO DE REFERENCIA REFERENCE CODE ASME Sec. V - Artigo 6	CRITÉRIO DE ACEITAÇÃO ACCEPTANCE STANDARD Código ASME Sec.VIII-Div.1-Ap. 8	CONDIÇÃO DA SUPERFÍCIE SURFACE CONDITION ESCOVADA	PRODUTO DE LIMPEZA CLEANING PRODUCT SOLVENTE	
EQUIPAMENTO DE ILUMINAÇÃO / LIGHTING EQUIPMENT Iluminação Natural do Setor com Auxílio de Lanterna LED 1.100.000 Lumens / Natural Lighting Sector Assists with Flashlight LED 1.100.000 Lumens		PROCEDIMENTO REV/ PROCEDURE REVISION BOS-17.00.283.BE.BR - Revisão-03		
MARCA E TIPO DO PENETRANTE: MARK AND TYPE OF PENETRANT <input checked="" type="checkbox"/> Visível / Visible <input type="checkbox"/> Fluorescente / Fluorescent	METAL CHEK VP 30	MARCA E TIPO DO REVELADOR: MARK AND TYPE OF DEVELOPER <input checked="" type="checkbox"/> Aquoso / Aqueous <input type="checkbox"/> Não Aquoso / Non Aqueous	METAL CHEK DL 70	TIPO DO REMOVEDOR TYPE OF REMOVER AGUA

MAPA E REGISTROS DAS INDICAÇÕES / MAP AND RECORD OF INDICATIONS

391216

ENSAIO APLICADO NAS SOLDAS: / TEST USED IN WELDING:

- 1) JUNTAS CIRCUNFERENCIAIS / JOINT CIRCUMFERENCE: C1 e C2.
- 2) NOS BOCAIS / IN NIPPLES: W(n).
- 3) SUPORTE E SELAS / IN SUPPORT PLATE AND SADDLES: S.

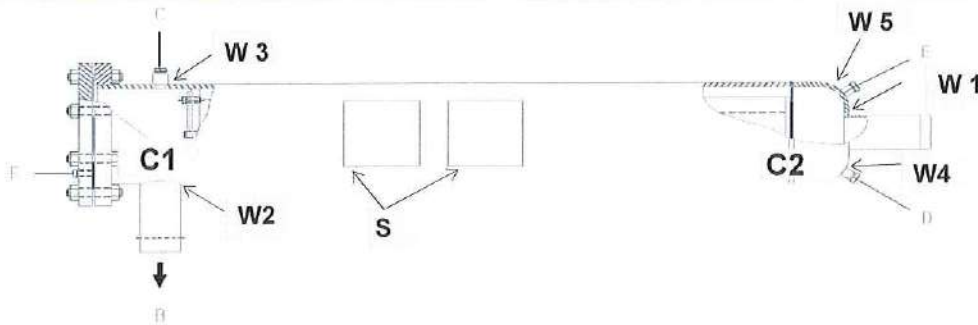

OUTROS INSTRUMENTOS USADOS / OTHERS INSTRUMENTS USED

- 1 -Luxímetro Digital / Digital Lux Meter: Minipa MLM-1011 (LUX-01)
- 2 -Termômetro Infravermelho Portátil / Portable Infrared Thermometer: Minitemp Raytec MT4 (TER-012)

TIPO DA INDICAÇÃO / TYPE OF INDICATION	RESULTADOS / RESULTS
FF - FALTA DE FUSÃO / LACK OF FUSION MO - MORDEDURA / UNDERCUT DL - DUPLA LAMINAÇÃO / LAMINATION PO - PORO / GAS PORE OV - SOBREPOSIÇÃO / OVERLAP TL - TRINCA LONGITUDINAL / LONGITUDINAL CRACK TR - TRINCA TRANSVERSAL / TRANSVERSE CRACK L-LINEAR - AR-ARREDONDADA / ROUNDED	A - APROVADO / APPROVED R - REPROVADO / REJECTED EC - EXAME COMPLEMENTAR / COMPLEMENT EXAM

Johnson Controls BE do Brasil Ltda Inspetor / Examiner TIAGO FURLA Inspetor LP Nível II SNT 21	AUTHORIZED INSPECTOR	CLIENTE / CLIENT
--	-----------------------------	-------------------------



RELATÓRIO DE TESTE TEST REPORT

No. (Nr.):

FO 147/2021

CLIENTE (CUSTOMER): MARFRIG BATAGUASSU	O.P. (PRODUCTION ORDER)/DRAWING 1013997/553E0014G03BR	
EQUIPAMENTO (EQUIPMENT): FILTRO OLEO	P.I. (SALE ORDER): E-32107D.026-02	DATA (DATE): 19/09/2021
FO-CX2.1/2 POL	391217	

TIPO DE TESTE (TYPE TEST)

 TESTE PNEUMÁTICO
(PNEUMATIC TEST) TESTE HIDROSTÁTICO
(HYDROSTATIC TEST)

TESTE DE RESISTÊNCIA (RESISTANCE TEST)

	GAS		PRESSÃO / bar (PRESSURE / bar)	DURAÇÃO (TIME)	RESULTADO (RESULT)
	N2	AR (AIR)			
CORPO / CASCO (SHELL)		x	32	30 SEG	OK
CABEÇOTES (HEAD)					
SERPENTINAS (SERPENTIN)					

MANÔMETRO UTILIZADO (MANOMETER USED): MA 145 MA 136

OBSERVAÇÃO (OBSERVATION): OCORREU VAZAMENTO SIM NÃO

TESTE DE ESTANQUEIDADE (LEAK TEST)

	GAS			PRESSÃO / bar (PRESSURE / bar)	DURAÇÃO (TIME)	RESULTADO (RESULT)
	N2	R22	AR (AIR)			
CORPO / CASCO (SHELL)			x	28	30 min	OK
CABEÇOTES (HEAD)						
SERPENTINAS (SERPENTIN)						

MANÔMETRO UTILIZADO (MANOMETER USED): MA 145 MA 136

OBSERVAÇÃO : REALIZADO TESTE DE ESTANQUEIDADE COM ESPUMA DE SABÃO
(THE LEAK TEST WAS REALIZED WITH SOAP FOAM)

(OBSERVATION) TESTE REALIZADO COM DETECTOR ELETRÔNICO DE VAZAMENTOS
MODELO: INFICON D - TEK 15
(THE TEST WAS REALIZED WITH LEAK ELETRONIC DETECTOR MODEL:
INFICON D - TEK 15)

OBSERVAÇÃO GERAL (REMARKS)

Tiago Furlan
Quality Specialist
Johnson Controls
OPERADOR (OPERATOR)Sueli Moraes
Quality Analyst
Johnson Controls
INSPETOR (INSPECTOR)

CLIENTE (CLIENT)

		RELATÓRIO DE ENSAIO POR LÍQUIDO PENETRANTE LIQUID PENETRANT EXAMINATION REPORT		Nº FO1147/21TF PAGE: 1 / 1
CLIENTE / CLIENT MARFRIG	PEDIDO / SALES ORDER 32107D026	FORNECEDOR / SUPPLIER NA	DATA / DATE SEPT 14, 2021	
EQUIPAMENTO / EQUIPMENT FILTRO DE OLEO FO43DN73	DES. / ITEM / DRAWING 553E0014BR	MATERIAL/ESPESSURA MATERIAL / THICKNESS SA 106 B / 8" SCH40	TÉCNICA / TECHNIQUE II A	
CÓDIGO DE REFERENCIA REFERENCE CODE ASME Sec. V - Artigo 6	CRITÉRIO DE ACEITAÇÃO ACCEPTANCE STANDARD Código ASME Sec.VIII-Div.1-Ap. 8	CONDIÇÃO DA SUPERFÍCIE SURFACE CONDITION ESCOVADA	PRODUTO DE LIMPEZA CLEANING PRODUCT SOLVENTE	
EQUIPAMENTO DE ILUMINAÇÃO / LIGHTING EQUIPMENT Iluminação Natural do Setor com Auxílio de Lanterna LED 1.100.000 Lumens / Natural Lighting Sector Assists with Flashlight LED 1.100.000 Lumens		PROCEDIMENTO REV/ PROCEDURE REVISION BOS-17.00.283.BE.BR - Revisão-03		
MARCA E TIPO DO PENETRANTE: MARK AND TYPE OF PENETRANT <input checked="" type="checkbox"/> Visível / Visible <input type="checkbox"/> Fluorescente / Fluorescent	METAL CHEK VP 30	MARCA E TIPO DO REVELADOR: MARK AND TYPE OF DEVELOPER <input checked="" type="checkbox"/> Aquoso / Aqueous <input type="checkbox"/> Não Aquoso / Non Aqueous	METAL CHEK DL 70	TIPO DO REMOVEDOR TYPE OF REMOVER AGUA

MAPA E REGISTROS DAS INDICAÇÕES / MAP AND RECORD OF INDICATIONS

391217

ENSAIO APLICADO NAS SOLDAS: / TEST USED IN WELDING:

- 1) JUNTAS CIRCUNFERENCIAIS / JOINT CIRCUMFERENCE: **C1 e C2.**
- 2) NOS BOCAIS / IN NIPPLES: **W(n).**
- 3) SUPORTE E SELAS / IN SUPPORT PLATE AND SADDLES: **S.**

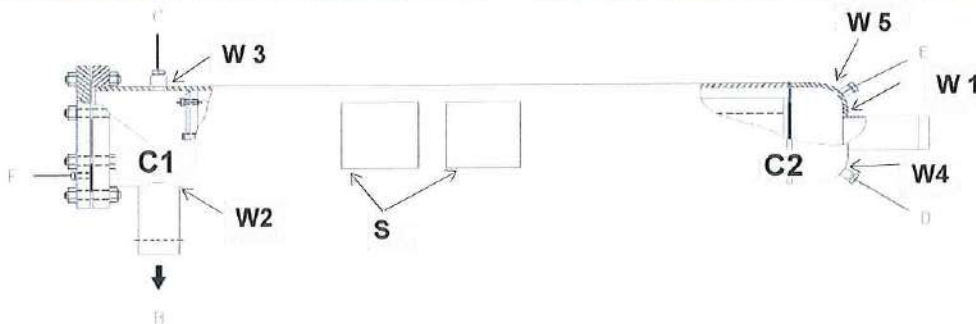

OUTROS INSTRUMENTOS USADOS / OTHERS INSTRUMENTS USED

- 1 -Luxímetro Digital / Digital Lux Meter: Minipa MLM-1011 (LUX-01)
- 2 -Termômetro Infravermelho Portátil / Portable Infrared Thermometer: Minitemp Raytec MT4 (TER-012)

TIPO DA INDICAÇÃO / TYPE OF INDICATION	RESULTADOS / RESULTS
FF - FALTA DE FUSÃO / LACK OF FUSION MO - MORDEDURA / UNDERCUT DL - DUPLA LAMINAÇÃO / LAMINATION PO - PORO / GAS PORE OV - SOBREPOSIÇÃO / OVERLAP TL - TRINCA LONGITUDINAL / LONGITUDINAL CRACK TR - TRINCA TRANSVERSAL / TRANSVERSE CRACK L-LINEAR - AR-ARREDONDADA / ROUNDED	A - APROVADO / APPROVED R - REPROVADO / REJECTED EC - EXAME COMPLEMENTAR / COMPLEMENT EXAM

Johnson Controls BE do Brasil Ltda Inspetor / Examiner TIAGO FURLAN Inspetor LP Nível II SNT TC 11721	AUTHORIZED INSPECTOR	CLIENTE / CLIENT
---	-----------------------------	-------------------------

CLIENTE: MAR-FRIG Botaguiassu P.I.: E-32J07D.026-0J

EQUIPAMENTO: Unidade Compressor RWS 11 399 REFRIGERANTE: R717 CONFIG. COMP.: SGC 2817

SERIE: 11552F12058773 DATA: 29/09/2021 VOLUME: _____

TIPO DE CONTROLADOR

UNISAB III 110V 220V VERSÃO: _____ QUANTUM HD 110V 220V

VERSÃO: Q.6 22.14

Número de Série do Controlador: CUL E 67918815

Número de Série do Display: Pa EE-0206

SOLENÓIDES	TRANSDUTORES PRESSÃO	SENSORES DE TEMPERATURA												
<input type="checkbox"/> CAPACIDADE <input type="checkbox"/> VOLUME <input type="checkbox"/> INJEÇÃO LÍQUIDO <input type="checkbox"/> RESF. DAS TAMPAS <input type="checkbox"/> RETORNO ÓLEO <input type="checkbox"/> ECONOMIZER	<input type="checkbox"/> SUCÇÃO <input type="checkbox"/> DESCARGA <input type="checkbox"/> ÓLEO <input type="checkbox"/> ÓLEO DIFERENCIAL <input type="checkbox"/> INTERMEDIÁRIA <input type="checkbox"/> ECONOMIZER	<input type="checkbox"/> SUCÇÃO <input type="checkbox"/> DESCARGA <input type="checkbox"/> SAÍDA ÁGUA (PROCESSO) <input type="checkbox"/> SEPARADOR ÓLEO <input type="checkbox"/> ÓLEO <input type="checkbox"/> INTERMEDIÁRIA												
ACELERÔMETRO <input checked="" type="checkbox"/> VIBRAÇÃO COMPRESSOR SUC. <input checked="" type="checkbox"/> VIBRAÇÃO COMPRESSOR DESC. <input checked="" type="checkbox"/> VIBRAÇÃO MOTOR EIXO <input checked="" type="checkbox"/> VIBRAÇÃO MOTOR OPOSTO EIXO	SENSOR TEMPERATURA MOTOR <input checked="" type="checkbox"/> MOTOR - LADO DO EIXO <input checked="" type="checkbox"/> MOTOR - LADO OPOSTO AO EIXO <input checked="" type="checkbox"/> MOTOR - BOBINA 1 ESTATOR <input checked="" type="checkbox"/> MOTOR - BOBINA 2 ESTATOR <input checked="" type="checkbox"/> MOTOR - BOBINA 3 ESTATOR	SOLENÓIDES <input type="checkbox"/> 220VCA <input type="checkbox"/> 110VCA <input checked="" type="checkbox"/> 24VCC TESTE ELÉTRICO / INSPEÇÃO VISUAL <table border="1"> <thead> <tr> <th>ALTERNATIVO</th> <th>PARAFUSO</th> </tr> </thead> <tbody> <tr> <td>25% <input type="checkbox"/> 67% <input type="checkbox"/></td> <td>SLIDE CARGA <input checked="" type="checkbox"/></td> </tr> <tr> <td>33% <input type="checkbox"/> 75% <input type="checkbox"/></td> <td>SLIDE DESCAR. <input checked="" type="checkbox"/></td> </tr> <tr> <td>37% <input type="checkbox"/> 83% <input type="checkbox"/></td> <td>VOLUME INCRE. <input checked="" type="checkbox"/></td> </tr> <tr> <td>50% <input type="checkbox"/> 87% <input type="checkbox"/></td> <td>VOLUME DECR. <input checked="" type="checkbox"/></td> </tr> <tr> <td>63% <input type="checkbox"/> 100% <input type="checkbox"/></td> <td></td> </tr> </tbody> </table>	ALTERNATIVO	PARAFUSO	25% <input type="checkbox"/> 67% <input type="checkbox"/>	SLIDE CARGA <input checked="" type="checkbox"/>	33% <input type="checkbox"/> 75% <input type="checkbox"/>	SLIDE DESCAR. <input checked="" type="checkbox"/>	37% <input type="checkbox"/> 83% <input type="checkbox"/>	VOLUME INCRE. <input checked="" type="checkbox"/>	50% <input type="checkbox"/> 87% <input type="checkbox"/>	VOLUME DECR. <input checked="" type="checkbox"/>	63% <input type="checkbox"/> 100% <input type="checkbox"/>	
ALTERNATIVO	PARAFUSO													
25% <input type="checkbox"/> 67% <input type="checkbox"/>	SLIDE CARGA <input checked="" type="checkbox"/>													
33% <input type="checkbox"/> 75% <input type="checkbox"/>	SLIDE DESCAR. <input checked="" type="checkbox"/>													
37% <input type="checkbox"/> 83% <input type="checkbox"/>	VOLUME INCRE. <input checked="" type="checkbox"/>													
50% <input type="checkbox"/> 87% <input type="checkbox"/>	VOLUME DECR. <input checked="" type="checkbox"/>													
63% <input type="checkbox"/> 100% <input type="checkbox"/>														

RESISTÊNCIAS

RESISTÊNCIA DO MOTOR ELÉTRICO
 RESISTÊNCIA DE AQUECIMENTO ÓLEO

DADOS DO MOTOR ELÉTRICO/COMPRESSOR

TIPO: J84 TC ISOLAÇÃO: F ROTAÇÃO: 1755

MARCA: WEG W22 FREQUÊNCIA: 60 Hz POTÊNCIA: 5.0

TENSÃO: 380 PROTEÇÃO: IP55 NÚMERO: 1062034226

DADOS DO MOTOR ELÉTRICO/BOMBA ÓLEO (SE HOUVER)

TIPO: 280S/M ISOLAÇÃO: F ROTAÇÃO: 3565

MARCA: WEG W40 FREQUÊNCIA: 60 Hz POTÊNCIA: 300

TENSÃO: 380 PROTEÇÃO: IP23 NÚMERO: 1061829239

OBSERVAÇÃO GERAIS

Verificado fisicamente se as bobinas de TODAS as válvulas solenóides estão corretas

Verificado se a tensão nominal do controlador está correta

Verificado Voltagem/Hz e Funcionamento da Boia Eletrônica de Óleo

Verificado Funcionamento dos Transdutores de Pressão e Temperaturas

Tamanho e Tipo do Fio Elétrico Conforme Desenho e Estrutura

Dentro do Painel Existe Uma Cópia do Desenho Elétrico e Manual

Anilhamento e Identificações dos Cabos Conforme Desenho

Verificado se os Jumpers do Acelerometro Estão Localizados Corretamente

Instalação Elétrica Está Completa Conforme Desenho e Estrutura

Ramon
INSPECTOR (ELÉTRICA)

Sueli Moraes
Quality Analyst
Johnson Controls
RESPONSÁVEL QUALIDADE

CLIENTE

Quantum HD Test Report

27-Aug-21
Test Software Version 2.0

Customer Name	Johnson Controls BE DO Brasil LTDA	Item Number	50
Order Number	302215865	Unit Number	2215865
Reference Number	302215865	UL Panel Number	CUL E67918815
		SAP Serial Number	10242K13611256

Screw Compressor	RWF	Main Bd Serial #	PQEE-0206	Oil Filter	<input checked="" type="checkbox"/>
Oil Pump	Full Time			Dual Discharge	<input type="checkbox"/>
Refrigerant	R717	Program Chip Ver	12.14	Liquid Injection	<input type="checkbox"/>
Language	English			Dual Pumps	<input type="checkbox"/>
Pressure Units	PSIG/Hg	Board	Quantum 6	Main Liquid Inject	<input type="checkbox"/>
Temperature Units	Deg. F	Anlg Bd 1 Serial #	AQFE-0147	Balance Piston	<input type="checkbox"/>
Drive Type	Electric	Anlg Bd 1 Revision	D	Oil Log	<input type="checkbox"/>
Panel For	Interco Retrofit	Anlg Bd 1 Prog Ver	3.01	Ram DBS	<input type="checkbox"/>
Panel Voltage	220V	Anlg Bd 1 Opt Addon	<input type="checkbox"/>		
VI Low	2.2				
VI High	5				
VI Deadband	0.2				
Separator Vel Ref	2.0%				
Compressor Ratio	4				
Slide Valve Travel	196	Dig Bd 1 Serial #	DPLE-0579		
High Disch Pres Val	239.7	Dig Bd 1 Revision	V		
Suction Transducer	200	Dig Bd 1 Prog Ver	1		
Discharge Transducer	500				
Oil Transducer	500				
Filter Transducer	500				

Assembler Clock #	3074
Tester Clock #	4569
Approved Date	8/27/2021

Comments: Customer will finish setup in field!!
Install Digital Bd #1 w/ALL Mods 1-24
Install 2nd Circuit Breaker for Oil Heater 1000W
Install E-Stop

Relatório de Alinhamento de Eixos **SKF**

Nome do relatório: Marfrig Batagussu

ID da máquina: 11552F12058773

Operador: NILVANDE

Data: 24-9-2021

Alinhamento prévio:---

Instrumento:TKSA-41

Nº de série MU-M: TKSA41-M-1627-0097

Nº de série MU-S: TKSA41-S-1633-0129

Temperatura da Unidade Medição: 29.4°C

Comentários:

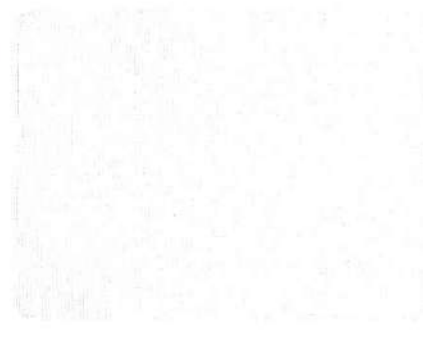
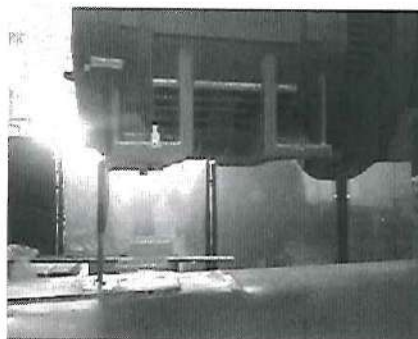
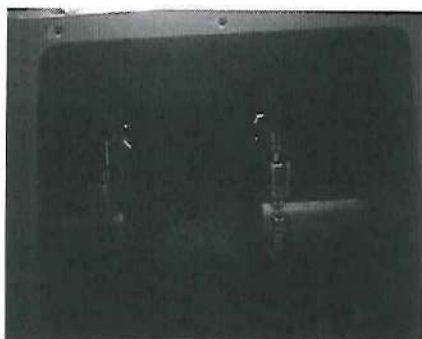

Pé manco

Pé manco verificado:Não
Conforme encontrado

Pé manco corrigido:Não
Conforme corrigido

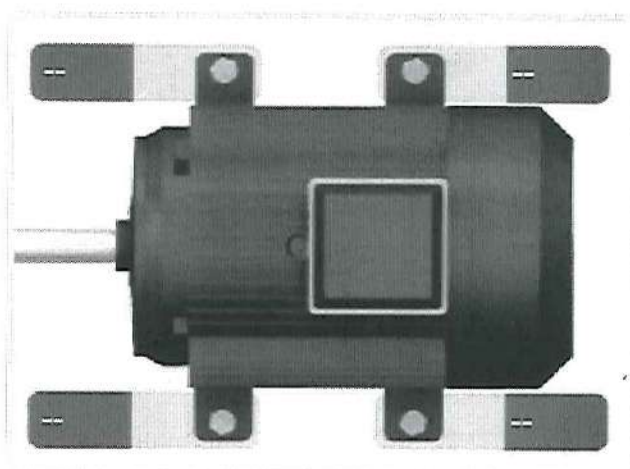
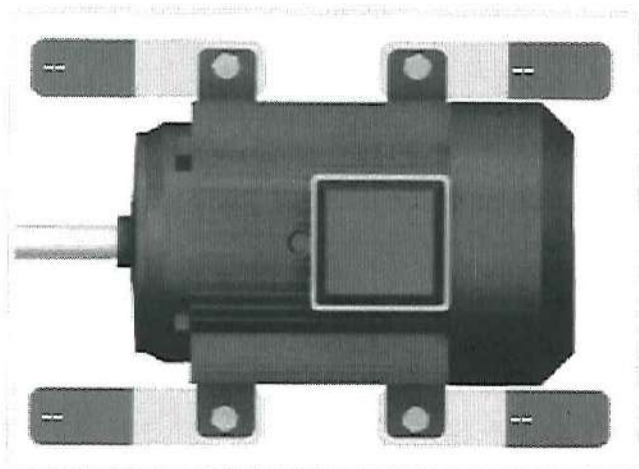

Distâncias

Tolerâncias

mm/100 mm mm

0.08

0.10

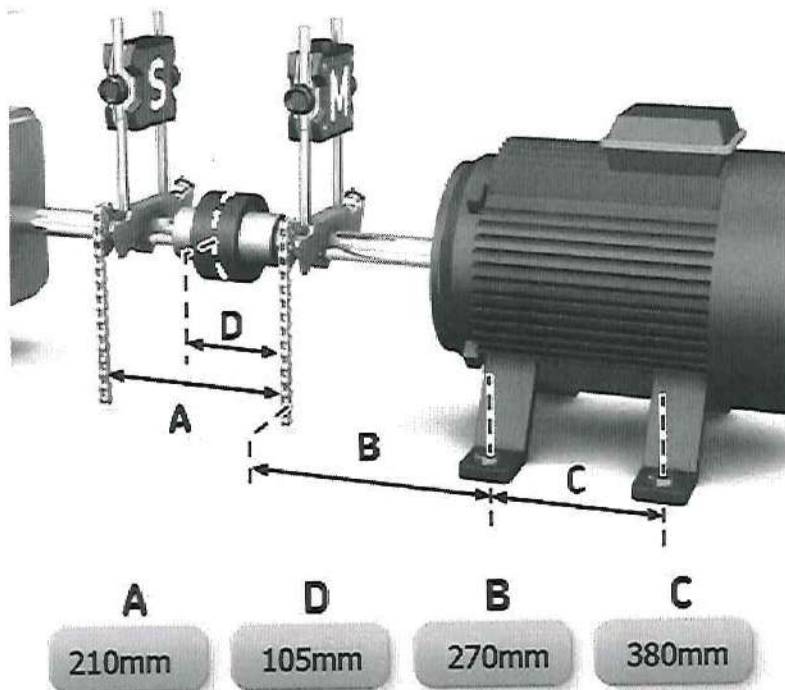

Resultados do alinhamento

Horizontal: Vista superior

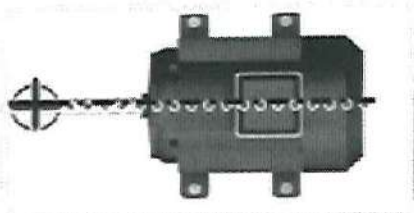

Conforme encontrado

	0.01 mm/100 mm	✓
	0.07 mm	✓

Conforme corrigido

	-0.07 mm/100 mm	✓
	0.03 mm	✓

Vertical: Vista lateral

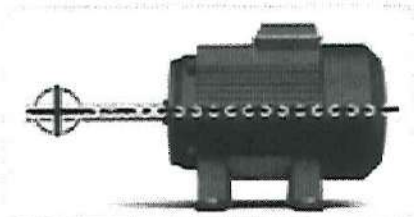

Conforme encontrado

	-0.03 mm/100 mm	✓
	-0.15 mm	≈

Conforme corrigido

	0.01 mm/100 mm	✓
	-0.14 mm	≈

Assinatura

Data: 24/09/21

Sueli Moraes
Quality Analyst
Johnson Controls

Folga tolerada: Sim



Relatório de Execução e Inspeção de Pintura

Nº.:
 DATA ABERT.: 26/19/2021
 DATA FECHAM.: 27/19/2021

CLIENTE: MARFRIG GLOBAL FOODS LOCAL: Planta Sorocaba
 Nº. PROCEDIMENTO: BR-PROD-653-WI-BTS-PO
 EQUIPAMENTO: UNIDADE COMPRESSORA RWF II 399 Nº. PI: E-32107D.026-01
 DESENHO ESTRUTURA: 4847CF399-032 Rev

CARACTERÍSTICA DA SUPERFÍCIE
 GRAUS DE INTEMPERISMO

SUPERFÍCIE SEM PINTURA - N/A SUPERFÍCIE COM PINTURA
 Grau A Grau B Grau C Grau D Grau 8 Grau 6 Grau 4 Grau 2 Grau 0

METODO DE PREPARO DE SUPERFÍCIE APLICADO

FERRAM. MANUAIS OU MECÂNICAS JATEAMENTO ABRASIVO HIDROJATEAMENTO - N/A
 Limpeza Solvente Lixamento Leve Sa 1 Sa 2 WJ 1 WJ 2
 St-2 St-3 Lavagem Sa 2½ WJ 3 WJ 4

Dados da Execução da Pintura

ITENS VERIFICADOS	Camadas			
	FUNDO	ACABAMENTO		
Código JCI Tinta	12331724	12331723-AS		
Temperatura do Ar °C	30C	30C		
Temp. da Superf. °C	27C	28C		
Umidade Relativa Ar %	55%	50%		
Ponto de Orvalho °C	19.5C	18.0C		
Fabricante	WEG	WEG		
Certif. da Tinta				
Cor	CINZA	VERDE		
Lote Comp. A	2534045	2558851		
Lote Comp. B	2628787	2466885		
Validade Comp. A	02.2022	03.2022		
Validade Comp. B	06.2022	10.2021		
Data Início Aplicação	26.9.2021	27.9.2021		
Hora Início Aplicação	13:45 H	8:30 H		
Método de Aplicação	AIRLESS	AIRLESS		
Data Término Aplicação	26.9.2021	27.9.2021		
Hora Término Aplicação	16:00 H	16:55 H		
Espessura camada seca	60µ	65µ		

Dados da Inspeção da Pintura

Espessura camada seca	OK	OK		
Teste de aderência				
Visto aprovação do C.Q.				
Visto aprovação da Fiscalização				

Ensaio de Descontinuidade Sim Não AP RP

Instrumentos utilizados:	ID	Data validade calibração	Observações:
Termohigrômetro:	TH-03	31/10/2021	ORDEM DE PRODUÇÃO = 1014298
Termômetro laser:	TER-013	30/11/2021	
Medidor de camada:	MEC-02	30/12/2021	

Operador Visto / Data 27.9.2021	Inspetor Qualidade Visto / Data Sueli Moraes Quality Analyst Johnson Controls	Inspetor N-I Visto / Data
--	--	---------------------------

Legenda: AP (Aprovado), RP (Reprovado), N/A (Não Aplicável), R (Rolo), T (Trincha), P (Pistola).

BR-PROD-590-FORM-BTS-PO - REV 01



Relatório de Execução e Inspeção de Pintura

Nº.:
 DATA ABERT.: 26/9/2021
 DATA FECHAM.: 27/9/2021

CLIENTE: MARFRIG GLOBAL FOODS LOCAL: Planta Sorocaba
 Nº. PROCEDIMENTO: BR-PROD-653-WI-BTS-PO
 EQUIPAMENTO: UNIDADE COMPRESSORA RWF II 399 Nº. PI: E-32107D.026-01
 DESENHO ESTRUTURA: 4847CF399-032 Rev

CARACTERISTICA DA SUPERFICIE
 GRAUS DE INTEMPERISMO

SUPERFÍCIE SEM PINTURA - N/A
 Grau A Grau B Grau C Grau D
 SUPERFÍCIE COM PINTURA
 Grau 8 Grau 6 Grau 4 Grau 2 Grau 0

MÉTODO DE PREPARO DE SUPERFICIE APLICADO

FERRAM. MANUAIS OU MECÂNICAS
 Limpeza Solvente Lixamento Leve St-2 St-3 Lavagem
 JATEAMENTO ABRASIVO
 Sa 1 Sa 2 Sa 2½ Sa 3
 HIDROJATEAMENTO - N/A
 WJ 1 WJ 2 WJ 3 WJ 4

Dados da Execução da Pintura

ITENS VERIFICADOS	Camadas			
	FUNDO	ACABAMENTO		
Código JCI Tinta	12331724	12331723-AS		
Temperatura do Ar °C	30°C	30°C		
Temp. da Superf. °C	27°C	28°C		
Umidade Relativa Ar %	55%	50%		
Ponto de Orvalho °C	19.5°C	18.0°C		
Fabricante	WEG	WEG		
Certif. da Tinta				
Cor	CINZA	VERDE		
Lote Comp. A	2534045	2558851		
Lote Comp. B	2628787	2466885		
Validade Comp. A	02.2022	03.2022		
Validade Comp. B	06.2022	10.2021		
Data Início Aplicação	26.9.2021	27.9.2021		
Hora Início Aplicação	13:45 H	8:30 H		
Método de Aplicação	AIRLESS	AIRLESS		
Data Término Aplicação	26.9.2021	27.9.2021		
Hora Término Aplicação	16:00 H	16:55 H		
Espessura camada seca	60µ	65µ		

Dados da Inspeção da Pintura

Espessura camada seca	OK	OK		
Teste de aderência				
Visto aprovação do C.Q.				
Visto aprovação da Fiscalização				

Ensaio de Descontinuidade Sim Não AP RP

Instrumentos utilizados:	ID	Data validade calibração	Observações:
Termohigrômetro:	TH-03	31/10/2021	
Termômetro laser:	TER-013	30/11/2021	
Medidor de camada:	MEC-02	30/12/2021	

ORDEM DE PRODUÇÃO = 1014298

Operador Visto / Data 27.9.2021	Inspetor Qualidade Visto / Data Sueli Moraes Quality Analyst Johnson Controls	Inspetor N-I Visto / Data
--	--	---------------------------

Legenda: AP (Aprovado), RP (Reprovado), N/A (Não Aplicavel), R (Rolo), T (Trincha), P (Pistola).

BR-PROD-590-FORM-BTS-PO - REV 01



6) TROCADOR DE CALOR
HEAT EXCHANGER

VAHTERUS	Asiakirja ja numero		Document and number		Rev.	Rev.
	DBI-61132		DBI-61132		00	
DATA BOOK INDEX				Sivu		Page
						1 of 2
Laatinut	Prepared by	Tarkastanut	Checked by	Hyväksynyt	Approved by	Pvm
Susanna Ventelä						Date
						20.9.2021

DBI-61132

END DOCUMENTATION OF HEAT EXCHANGER

DATA BOOK INDEX

Customer's Information:

Serial No's: 61132
Ref. T21 /16
Order No:
Customer: Johnson Controls Brazil

Rev. No	Ehd.	Proposed by	Tark.	Checked by	Hyv.	Appr. by	Modified	Muutettu	Pvm	Date

VAHTERUS		Asiakirja ja numero		Document and number		Rev.	Rev.
		DBI-61132		DATA BOOK INDEX		00	
Laatinut		Tarkastanut	Checked by	Hyväksynyt	Approved by	Sivu	Page
Prepared by Susanna Ventelä						2 of 2	
						Pvm	Date
						20.9.2021	

DATA BOOK INDEX:

1) DESIGN

- Technical Datasheet
- Dimensional Drawing
- Strength Calculations

2) WELDING

- Welding Map

3) MATERIALS

- Material List + Material Certificates

4) CERTIFICATES

- Final Inspection Certificate
- Name Plate Drawing (NR13)

5) MANUALS

- Operation and Maintenance Manual

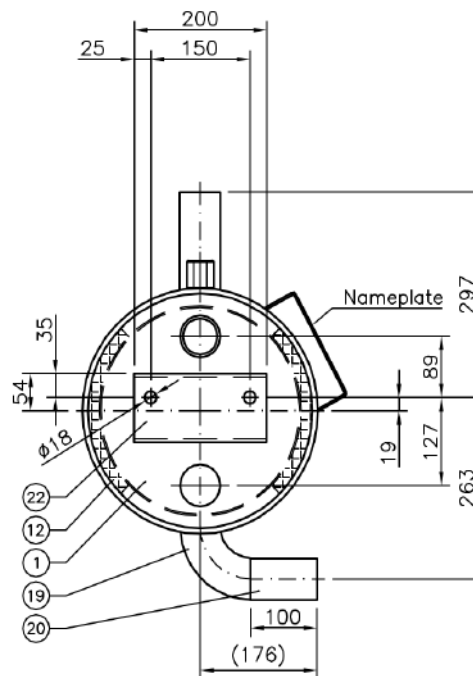
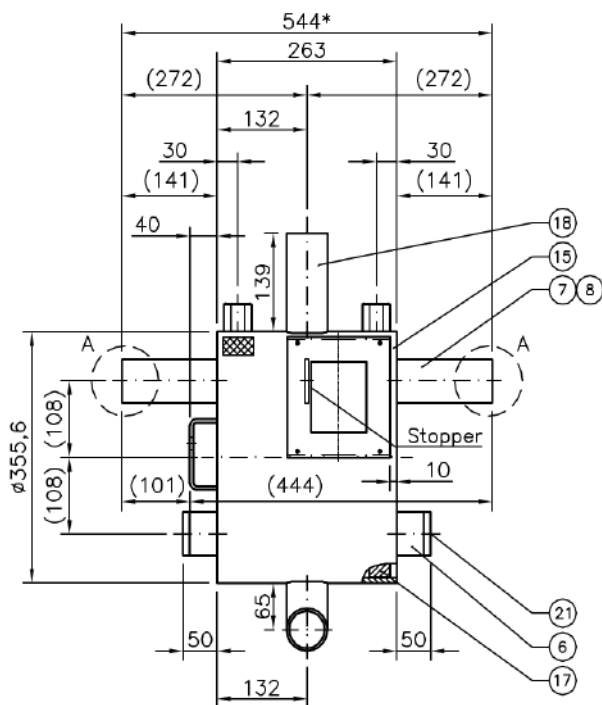
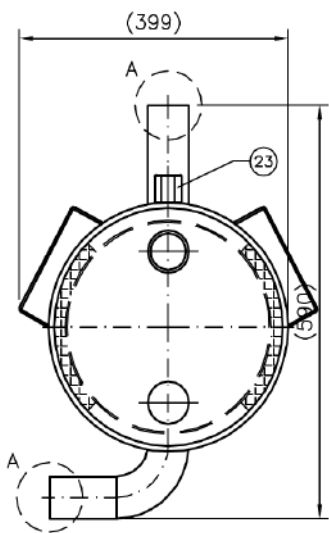

VAHTERUS
Plate & Shell Heat Exchanger
23600 Kalanti Finland

Tipo / Type: PSHE 3HH-66/2/1 Ano construído / Year built: _____

Fabricante N.º / Manuf. Nr.: 61132 Lado das placas / Plate side: _____ Lado do casco / Shell side: _____

Pressão de projeto (mínima) / Design pressure (min/max): -100/2799 (-1/28.5) kPa(g) (kgf/cm²)	Pressão de projeto (mínima) / Design pressure (min/max): -100/2799 (-1/28.5) kPa(g) (kgf/cm²)
PMTA (corrosão quente) / MAWP (hot and corroded): 2799 (28.5) kPa(g) (kgf/cm²)	PMTA (corrosão quente) / MAWP (hot and corroded): 2799 (28.5) kPa(g) (kgf/cm²)
Temperatura de projeto / Design temperature (min/max): 0/130 °C	Temperatura de projeto / Design temperature (min/max): 0/130 °C
Volume: 5.2 L	Volume: 8.1 L
Pressão de teste hidrostático / Test pressure: 4020 (41.0) kPa(g) (kgf/cm²)	Pressão de teste hidrostático / Test pressure: 4020 (41.0) kPa(g) (kgf/cm²)
Data do teste / Test date: _____	Data do teste / Test date: _____
Meio / Medium: Óleo / Oil	Meio / Medium: Refrigerante / Água / Refrigerant / Water
Peso (vazio/in operation) / Weight (empty/in operation): 105 / 118 Kg	Peso (vazio/in operation) / Weight (empty/in operation): 105 / 118 Kg
Norma de projeto/código / Design code: PED 2014/68/EU + AD 2000 Calculation + NR-13	Norma de projeto/código / Design code: PED 2014/68/EU + AD 2000 Calculation + NR-13
Categoria/Grupo/Classe / Category/Group/Class: IV / 5 / B	Categoria/Grupo/Classe / Category/Group/Class: IV / 5 / B
Sobreespressura de corrosão / Corrosion Allowance: S.S. 0 CS:1 mm	Sobreespressura de corrosão / Corrosion Allowance: S.S. 0 CS:1 mm
Materiais / Materials: AISI316L (Placas) P236GH	Materiais / Materials: AISI316L (Placas) P236GH

Standard Drawing Number:
C13-54-4086-2-BR Rev. B

Detail A
Nozzle DN50
pos. 8, 18 & 20
1:2

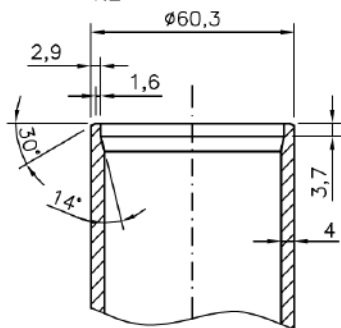

ID Field / Tunnistekenttä
Unit to be equipped with lifting lug M20, DIN 580

Rev.	Modification	Name	Date
	Marking of the unit: Serial number to be stamped to the shell, location marked in dwg with	Customer: Johnson Controls Brazil	
	Designed by: HH 201118	End Customer:	
	Checked by: MLE 201118	Order Nr.:	
Manufacturer: VAHTERUS Vahterus Oy Phone: +358 2 840 70 Pruukintie 7 Telefax: +358 2 840 7299 FIN-23600 Kalanti E-mail: sales@vahterus.com FINLAND www.vahterus.com		Plate & Shell® Heat Exchanger PSHE 3HH-66/2/1 Liquid-liquid / Oil Cooler	
	Ref. T21/16	Serial number(s): 61132	Scale: not in scale
	Copyright of Vahterus whose property	Drawing number: 61132	Sheet: 01 Rev: 0 Sheets: 2 Size: A4
Plate & Shell is registered trademark of Vahterus Oy			



PSHE WELDED
HEAT EXCHANGERS

Strength Calculations
PED / AD-Merkblätter 2000

Date	24.7.2017
Serial Nb	-
Type	PSHE 3HH-66/2/1
Made by	RVI
Design Pressure	-1/28 barg
Design Temperature	0/130 °C

Page **1**
 Serial Nb -
 Type PSHE 3HH-66/2/1

SHELL **AD-B1**
 Material: P235GH EN 10216-2

Da	mm	355.6
p	barg	28
v		1.00
K	N/mm ²	191
K20	N/mm ²	235
C1	mm	1.6
C2	mm	1.0
S		1.5
s	mm	6.5
Chosen s	mm	8
Max testing pressure	barg	93.1

1)

B0/ 9.1
 B0 table 2
 (2)

1) seamless tube, v=1, with Plates v=0.85

END PLATE NOZZLE **AD-B1**
 Material: 1.4571 EN 10216-5 (cold formed)

Da	mm	60.3
p	barg	28
v		1
K	N/mm ²	200
K20	N/mm ²	245
C1	mm	0.60
C2	mm	0.0
S		1.5
s	mm	1.2
Chosen s	mm	3.6
Max testing pressure	barg	248.5

B0/ 9.1
 B0 table 2
 (2)

$$s = \frac{D_a \cdot p}{20 \frac{K}{S} \cdot v + p} + c_1 + c_2$$

Page 2
 Serial Nb -
 Type PSHE 3HH-66/2/1

Elbow AD-B1
 Material: P235GH | EN 10253-2 Type A, S, Model 3D

Da	mm	60.3
p	barg	36
v		1.00
K	N/mm ²	191
K20	N/mm ²	235
C1	mm	0.6
C2	mm	1.0
S		1.5
s	mm	2.4
Chosen s	mm	4.5
Max testing pressure	barg	293.8

*Relative pressure withstand factor of 0.77
 1)

B0/ 9.1
 B0 table 2
 (2)

1) seamless tube, v=1, with Plates v=0.85

END PLATE NOZZLE AD-B1
 Material: P235GH EN 10216-2

Da	mm	60.3
p	barg	28
v		1
K	N/mm ²	191
K20	N/mm ²	235
C1	mm	0.50
C2	mm	1.0
S		1.5
s	mm	2.2
Chosen s	mm	4
Max testing pressure	barg	263.1

B0/ 9.1
 B0 table 2
 (2)

$$s = \frac{D_a \cdot p}{20 \frac{K}{S} \cdot v + p} + c_1 + c_2$$

END PLATE**AD-B5**

Material:

P265GH EN 10028-2

Page **3**

Serial Nb -

Type PSHE 3HH-66/2/1

p	bar	28
D1	mm	344.8
di	mm	53.1
di/D1		0.154
Nb of Nozzles		2
CA1		1.198
C1		0.5
C=C1*CA1		0.599
K	N/mm2	222
K20	N/mm2	255
S		1.5
c1	mm	0.0
c2	mm	1.0
s	mm	29.4
Deflection	mm	0.31
z(min)	mm	8.0
Chosen s	mm	30
Max testing pressure	barg	48.4

+)

Table 1h

B0/ 9.1

B0/ 9.1

(2)

**)

*)

*) TGL 32903/09 edition 1979 (DDR-standard)

**) Deflection= $0.0696 \cdot p \cdot (D1/2)^4 / (E \cdot s^3)$, E=206000 N/mm2

+) In the same cross section

$$s = C \cdot D_1 \cdot \sqrt{\frac{p \cdot S}{10 K}} + c_1 + c_2 \quad (2)$$

END PLATE FOR NOZZLE AD-B5
 Material: P265GH EN 10028-2

Page 4
 Serial Nb -
 Type PSHE 3HH-66/2/1

p	bar	28
D1	mm	53.1
di	mm	
di/D1		
CA1		1.0
C1		0.4
C=C1*CA1		0.4
K	N/mm2	230
K20	N/mm2	265
S	N/mm2	1.5
c1	mm	0.0
c2	mm	1.0
s	mm	3.9
Chosen s	mm	10.0
Max testing pressure	barg	528.7

table1 e

table1 e

draw. 21

table1 e

B0/ 9.1

B0/ 9.1

(2)

$$s = C \cdot D_1 \cdot \sqrt{\frac{p \cdot S}{10 K}} + c_1 + c_2$$

(2)

REINFORCEMENTS OF THE OPENINGS

AD-B9

Page 5

MINIMUM DISTANCE BETWEEN TWO OPENINGS

Serial Nb -

Material: Shell: P235GH EN 10216-2

Type PSHE 3HH-66/2/1

Reinforcement plate: P265GH EN 10028-2

Nozzle: P235GH EN 10216-2 & EN 10253-2 Type A, S, Model 3D

Nozzle		1	2
DN		50	50
p	bar	28	28
Du	mm	355.6	355.6
Se	mm	8.0	8.0
Se req (AD-B1)	mm	6.5	6.5
c1	mm	1.0	1.0
c2	mm	1.0	1.0
Se-c1-c2	mm	6.0	6.0
Di	mm	344	344
Di (nom)	mm	339.6	339.6
di+2*ss	mm	60.3	60.3
ss	mm	4.0	4.5
Ss req. (AD-B1)	mm	2.15	2.40
ss-c1-c2	mm	2.5	2.9
di	mm	56.0	55.5
di (nom)	mm	52.3	51.3
b	mm	0	0
h	mm	0	0
SA - c1-c2	mm	6.0	6.0
Min. Width	mm	0.0	0.0
Lmin	mm	84.3	84.3
b1max (c)	mm	45.5	45.5
Chosen dimension:			
b* (d)	mm	44.0	45.0
b(calc)=min(c,d)	mm	44.0	45.0
ls	mm	14.6	10.0
Ap	mm ²	13317	13355
ASigma1 **)	mm ²	36.6	29.4
ASigma2	mm ²	264.0	270.0
Asigma	mm ²	301	299
K (Nozzle)	N/mm ²	191	191
K20 (Nozzle)	N/mm ²	235	235
K (Plate)	N/mm ²	191	191
K20 (Plate)	N/mm ²	235	235
S		1.5	1.5
K/S	N/mm ²	127.6	127.6
p/10*(Ap/Asigma+1/2)	N/mm ²	125.4	126.3
Res%		2	1
Max testing pressure	barg	47.2	46.9
Lmin	mm	148	150
L4 (Alternative 1)	mm	104	105
L4 (Alternative 2)	mm	92	93
L5	mm	15	11
b1	mm	0	0
h1	mm	0	0

B1 (2)

*)

draw. 9

draw. 9

draw. 9

B1 (2)

draw. 9

draw. 9

draw. 9

draw. 9

draw. 9

draw. 9

4.3.1

draw. 9

draw. 9

draw. 9

draw. 9

draw. 9

draw. 9

draw. 9

draw. 9

draw. 9

draw. 9

draw. 9

draw. 9

draw. 9

draw. 9

draw. 9

draw. 9

draw. 9

draw. 9

draw. 9

draw. 9

draw. 9

draw. 9

draw. 9

draw. 9

draw. 9

draw. 9

draw. 9

draw. 9

draw. 9

draw. 9

draw. 9

draw. 9

draw. 9

draw. 9

draw. 9

draw. 9

draw. 9

draw. 9

draw. 9

draw. 9

draw. 9

draw. 9

draw. 9

draw. 9

draw. 9

draw. 9

$$\frac{p}{10} \left(\frac{A_p}{A_c} + \frac{1}{2} \right) \leq \frac{K}{S} \quad (1)$$

$$l_s = 1,25 \cdot \sqrt{(d_i + s_s - c_1 - c_2) \cdot (s_s - c_1 - c_2)} \quad (6)$$

$$l \geq 2 \cdot \sqrt{(D_i + s_A - c_1 - c_2) \cdot (s_A - c_1 - c_2)} \quad (8)$$

*) B0/9.2

**) Reduced Area due to lower strength: Asigma = (Ss-c1-c2)*ls * (2*(K/S)tube-p/10)/(2*(K/S)plate-p/10

TESTING PRESSURE

Page **6**
Serial Nb -
Type PSHE 3HH-66/2/1

p	barg	28
Test pressure	barg	40.2
Max testing pressure		
Shell	barg	93.1
Elbow 90°	barg	293.8
End Plate Nozzle SS	barg	248.5
End Plate Nozzle CS	barg	263.1
End Plate	barg	48.4
End Plate for nozzle	barg	528.7
Connections	barg	46.9

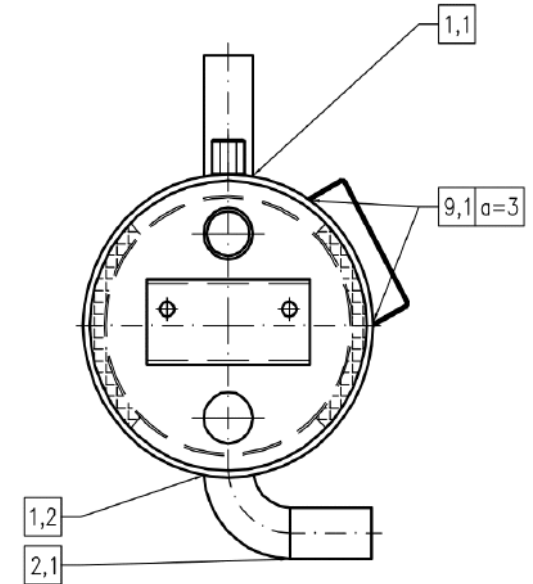
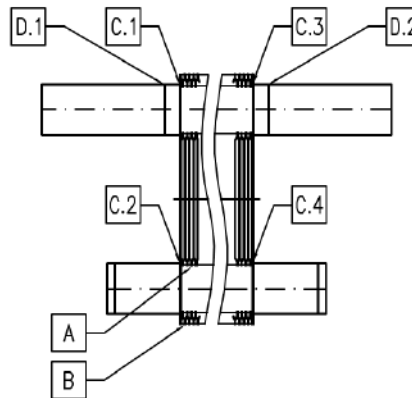
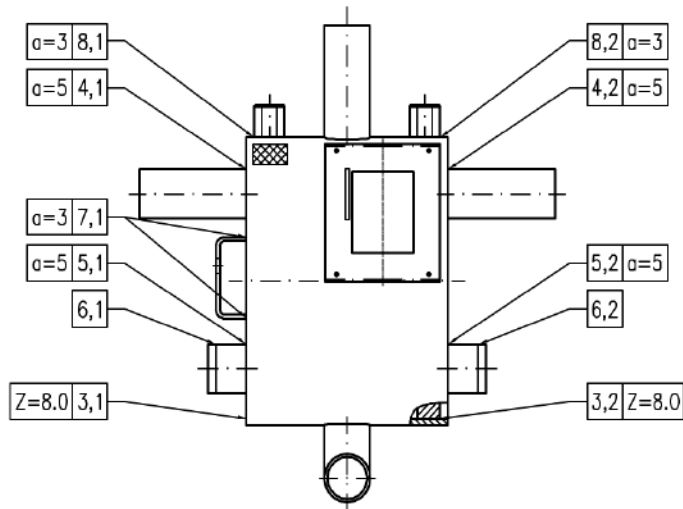
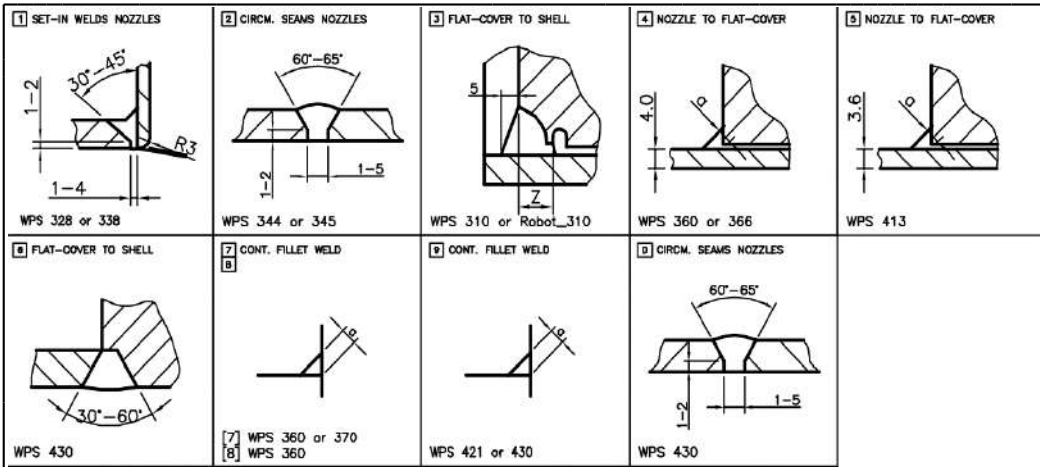

NDT Test procedures to be selected according to WPS:
Welding: EN15614-1 NDE: EN/AD-2000
ASME ASME

NDT scope to be determined according to design code



Rev.	Modification	Name	Date
	Marking of the unit: Serial number to be stamped to the shell, location marked in dwg with	Customer: Johnson Control Brazil	
Designed by:	HH 090120	End Customer:	
Checked by:	Tho 090120	Order Nr.:	
Tolerances: Acc. To ISO EN13920-C, except length marked * 0-100 plates, ±10; 101-200 plates, ±15; 201-300 plates, ±20; >300 plates, ±30.			
Manufacturer: VAHTERUS Vahterus Oy Phone: +358 2 840 70 Pruukintie 7 Telefax: +358 2 840 7299 FIN-23600 Kalanti E-mail: sales@vahterus.com FINLAND www.vahterus.com		Plate & Shell® Heat Exchanger PSHE 3HH-66/2/1 Welding / NDT Map	
Ref.	Serial number(s)	Scale	
T21/16	61132	not in scale	
Copyright of Vahterus	Drawing number	Sheet	Rev
whose property	61132	02	0
		Sheets	Size
		2	A4

Shell / Vaippa

Weld No	WPS No	Welding consumables	Welder Hitsaaja	NDE	Dekra	Remarks Huom!
1,1	328 or 338					Nozzle - Shell Yhde - Vaippa
1,2	328 or 338					Elbow - Shell Käyrä - Vaippa
2,1	344 or 345					Elbow - Nozzle Käyrä - Yhde
3,1	310 or Robot 310					End plate - Shell Pääty - Vaippa
3,2	310 or Robot 310					End plate - Shell Pääty - Vaippa
4,1	360 or 366					Nozzle - End Plate Pakkayhde - Pääty
4,2	360 or 366					Nozzle - End Plate Pakkayhde - Pääty
5,1	413					Nozzle - End Plate Pakkayhde - Pääty
5,2	413					Nozzle - End Plate Pakkayhde - Pääty
6,1	430			PT 100%		Nozzle - End Plate of Nozzle Pakkayhde - Päätyappu
6,2	430			PT 100%		Nozzle - End Plate of Nozzle Pakkayhde - Päätyappu
7,1	360 or 370					Mounting Bracket - End Plate Jalkarauta - Pääty
8,1	360					Lifting Lug Socket - Shell Muhviholkki - Vaippa
8,2	360					Lifting Lug Socket - Shell Muhviholkki - Vaippa
9,1	421 or 430					Nameplate Bracket - Shell Kilpiteline - Vaippa

Plate Pack / Pakka

Weld No	WPS No	Welding consumables	Welder Hitsaaja	NDE	Dekra	Remarks Huom!
A						Porthole Weld Pikkureikä
B						Perimeter Weld Ulkokehä
C.1						Nozzle to plate pack end plate Pakkayhde pakan päätyyn
C.2						Nozzle to plate pack end plate Pakkayhde pakan päätyyn
C.3						Nozzle to plate pack end plate Pakkayhde pakan päätyyn
C.4						Nozzle to plate pack end plate Pakkayhde pakan päätyyn
D.1	430					SS Nozzle to CS Nozzle Pakkayhde jatkoysteeseen
D.2	430					SS Nozzle to CS Nozzle Pakkayhde jatkoysteeseen

Rev.	Modification			Name	Date
	Marking of the unit: Serial number to be stamped to the shell, location marked in dwg with 			Customer: Johnson Control Brazil	
	Name	Date	Tolerances:	End Customer:	
Designed by:	HH	090120	Acc. To ISO EN13920-C, except length marked * 0-100 plates, ±10; 101-200 plates, ±15; 201-300 plates, ±20; >300 plates, ±30.	Order Nr.:	
Checked by:	Tho	090120			
Manufacturer:			Plate & Shell® Heat Exchanger PSHE 3HH-66/2/1 Welding / NDT Map		
VAHTERUS					
Vahterus Oy Pruukintie 7 FIN-23600 Kalanti FINLAND			Phone: +358 2 840 70 Telefax: +358 2 840 7299 E-mail: sales@vahterus.com www.vahterus.com		
Ref. T21/16		Serial number(s) 61132		Scale not in scale	
Copyright of Vahterus whose property		Drawing number 61132	Sheet 02	Rev 0	Sheets 2 Size A4
Plate & Shell is registered trademark of Vahterus Oy					

VAHTERUS**MATERIAL LIST**

Serial No. 61132	End Customer:	Rev. 0	Certificates according to:
Type: PSHE 3HH-66/2/1	Order No.	Date: 20.9.2021	EN-10204
Ref. V21/862	Certificate Nr	Made by: SVE	
Customer: Johnson Controls Brazil	Inspector: Vahterus (CE)		
	Design Code PED 2014/68/EU + AD 2000 Calculation + NR-13		

Pos	Description	Dimensions	Material	Charge Nb	Certificate	
1	Plate 3HH	Φ300 x 0.7	1.4404 EN 10028-7	459955	3.1	LE16323
2	Plate3HH	Φ300 x 0.7	1.4404 EN 10028-7	459955	3.1	LE16323
3	Plate3HH	Φ300 x 0.7	1.4404 EN 10028-7	459955	3.1	LE16323
6	Nozzle	Φ60.3 x 3.6	1.4571 EN 10216-5	57105	3.1	PU3309
7	Nozzle	Φ60.3 x 3.6	1.4571 EN 10216-5	57105	3.1	PU3309
8	Nozzle	Φ60.3 x 4	P235GH EN 10216-2	28227K	3.1	PU3335
15	Shell	Φ355.6 x 8 x 263	P235GH EN 10216-2	902651	3.1	PU3366
16	End plate	Φ339 x 30	P265GH EN 10028-2	54313052	3.1	LE16120
17	End plate	Φ339 x 30	P265GH EN 10028-2	54313052	3.1	LE16120
18	Nozzle	Φ60.3 x 4	P235GH EN 10216-2	28227K	3.1	PU3335
19	Elbow 90°	Φ60.3 x 4.5	P235GH EN 10253-2 Type A, S, Model 3D	E3650	3.1	SE5998
20	Nozzle	Φ60.3 x 4	P235GH EN 10216-2	28227K	3.1	PU3335
21	End plate for nozzle	Φ60.3 x 10	P265GH EN 10028-2	59077 032	3.1	LE16135
22	Mounting Bracket	PSHE-3 U-100	P265GH EN 10028-2	45256 141	3.1	LE16014
23	Socket	Ø40, L=40, M20	IMATRA 550 EN 10277-2	40640	3.1	SE5971

INSPECTION CERTIFICATE

(according to DIN EN 10204, type 3.1)



LE16323

Manufacturer:

Otelinox S.A.

Strada Soseaua Gaesti no. 16

Targoviste, 130087

Dambovita, Romania

No: 0042147273

Member of CISQ Federation



CERTIFIED MANAGEMENT SYSTEM
ISO 9001
Member of CISQ Federation



CERTIFIED MANAGEMENT SYSTEM
IATF 16949
Laboratory Accredited by RENAR, ISO/CEI 17025, Certificate no. LI 007



Customer: VAHTERUS OY
Customer Ord.No.: 1000386788/PO 055748/Art 03SL0300001A
Product: Strips
Steel grade: 1.4404/1.4401/2B; AISI 316L/AISI 316/2B

Melting process: E
Specification: AD2000W2/W10; PED 2014/68/EU; EN 10088-2/14; EN 10028-7/16; ASTM A 240M/19; ASME SA240/19; ISO 15156-3:2015(E)-NACE:MR0175

Coil No	Heat No	Weight (kg)	Std	Chemical analysis (%)											
				C	Mn	Si	P	S	Cr	Ni	Mo	Ti	N	Cu	Al
1L24/163-200250/A/2	0459955	3120.000		0.019	1.120	0.320	0.027	0.0010	16.700	10.050	2.090	xxxx	0.047	xxxx	xxxx

Surface and dimensional control, material identity test, intercrystalline corrosion acc. to DIN EN ISO 3651-2 and ASTM A 262E: O.K
 PREN=24.349

Extent of delivery				Test Results											
Coil No	Dimensions (mm)	Pallet No	Packing List No	Test No	Pos	Std	0.2%Y Str (N/mm2)	1%Y Str (N/mm2)	T/S (N/mm2)	Elong (A80%)	Elong (A50%)	Elong (A10%)	HV	Bending Test	Grain Size
1L24/163-200250/A/2	0.70 X 310 Slit	1000567847;1000567850 1000567851	42147273	76	T		313.0	345.0	636.0	50.5	51.5	xxxx	158.0	xxxx	xxxx
				77	B		309.0	341.0	622.0	51.5	52.5	xxxx	154.0	xxxx	xxxx

Heat treatment: 1080 °C/ Air cooling

T = Top B = Bottom Sample direction: transversal

Delivered product is in conformity with order requirements.

Marking: Producer Trade Mark, Material, Heat No., Coil-No.

Issued in agreement with TÜV SÜD Industrie Service GmbH (10/2002)
 QS approved acc. to PED, Annex I, Para. 4.3 by Notified Body 0036 (Certification no. DGR-0036-QS-W 23/2002/MUC-001)

WORK INSPECTOR
 CUTA VICTORIA



PU3309



INSPECTION CERTIFICATE
CERTIFICADO DE INSPECCION
CERTIFICAT DE RECEPCION
ABNAHMEPRÜFZEUGNIS
EN 10204:2004 / 3.1

Number: 713330 Rev:
Page: 1 / 5

Created on: Modified on:
Date: 05.02.2020

SCHOELLER-BLECKMANN Edelstahlrohr GmbH
2630 Ternitz, Rohrstrasse 1
Austria

TL: +43 2630 316-810
FAX: +43 2630 316-894
E-MAIL: wolfgang.hecher@sber.co.at

CUSTOMER DESCRIPTION/DESCRIPCIÓN DEL CLIENTE/KUNDENBEZEICHNUNG/COMMETTANT

CLIENT SOLD TO/SOLICITANTE/AUFTRAGGEBER/COMMETTANT

TSS AUSTRIA TUBACEX SERVICE SOLUTIONS AUSTRIA GMBH ROHRSTRASSE 1 2630 TERNITZ	SOLD TO:POLARPUTKI OY SOLD P.O. REF.:63778 SOLD ORDER REF.:348474 COPY NUMBER: 001
--	---

CLIENT ORDER/PEDIDO CLIENTE/KUNDEN AUFTRAGSNUMMER/NO.DE COMMANDE: 1007377

SALES ORDER/PEDIDO VENTAS/AUFTRAGSNUMMER/NO.DE COMMANDE D'USINE:

MATERIAL:SEAML. STAINL. STEEL TUBES/PIPES/TUBOS INOXIDABLES SIN SOLDADURA/TUBES INOX SANS SOUDURE/NAHTLOSE EDELSTAHLROHRE
HEAT-TREATED, PICKLED / TRATADO, DECAPADO / HYPERTREMPE, DECAPE / WÄRMEBEHANDELT, GEBEIZT, PASSIVATED AS PER ASTM A380 / PASIVADO SEGUN ASTM A380 / PASSIVÉ (ASTM A380) / PASSIVIERT (ASTM A380)
GRADE / ACERO / GRADE / WERKSTOFF: TP316TI,1.4571,
STANDARD / NORMA / STANDARD / LIEFERUNG NACH: AD 2000 W2/09.2016
ASME SECT.II PART.A SA312/SA312M-2017 ED.
ASTM A312/A312M-18A
EN 10216-5:2013 TC2
EN 10297-2:2005
CHEMICAL AND MECHANICAL PROPERTIES ACC. TO ASME SECT.II PART.A SA213/SA213M-2015 ED.
CHEMICAL AND MECHANICAL PROPERTIES ACC. TO ASTM A213/A213M-18B
AD 2000 W10/05.2016
CORROSION TESTED ACC. TO ASTM A262 PRACTICE E
CORROSION TESTED ACC. TO EN ISO 3651-2 "A"
ANSI/NACE MR0103/ISO 17945:2015
ANSI/NACE MR0175/ISO15156-3:2015
TRD 100 MAI 1991
TOLERANCES / TOLERANCIAS / TOLERANCES / TOLERANZEN NACH: ASME SECT.II PART.A SA999/SA999M-2017 ED.
ASTM A999/A999M-18
EN ISO 1127/03.97 D2/T2
RANDOM LENGTHS / LARGOS VARIABLES / LONGUEUR COURANTE / EINGEENGTE LÄNGE 5.000/7.000 MM
PLAIN ENDS / LISOS / EXTRÉMITÉ D'EQUERRE / GLATTE ENDEN,
DIMENSIONS/DIMENSIONES/DIMENSIONS/DIMENSIONS: 60,30 X 3,60 MM
COLD FINISHED/LAMINADOS EN FRIO/KALTGEFORMT/LAMINES A FROID

Sales Item	Client Item	Delivery No	Lot No.	Heat No	Pieces	Weight	Tot Lgth	Un Lgth
Pos Ped.	Pos Clnt	N° Entrega	N° lote	Colada	Piezas	Peso	Long. Tot	Long. Un
AuftrgPos	Kunde Pos	Lieferung	Los Nr.	Schmelze	Stück	Gewicht	Gesamtlänge	Längentyp
Usine Pos	Com. Pos	Avis. d'exp	Lot d'inspection	Coulée	Pcs	Poids	Tolength	Long. Un
20		8170086252	278597	57105	52	1.564 KG	304,69 M	5000-7000 MM



Certified Management System acc. to ISO 9001, ISO 14001 and OHSAS 18001 by LRQA

We hereby certify that the material herein described has been manufactured, sampled, tested, and inspected in accordance with above standards and specifications and satisfies order's requirements. This certificate is issued by a computerized system and it is valid without original signature. In case the owner of the certificate would release as a copy of it, he must attest its conformity to the issued, assuming the responsibility for any unlawful or TUBACEX, not allowed use. Any forgery or falsification of this certificate shall legally prosecuted.

SCHOELLER-BLECKMANN EDELSTAHLROHR GMBH

Riegler

FR. N. RIEGLER
(WORKS INSPECTOR)

RAW MATERIAL/DATOS MATERIAL/VORMATERIAL/MATIERE PREMIERE

Heat Nr: 57105 **Supplier:** ACERALAVA (SPAIN) **Method:** Electric furnace+AOD

CHEMICAL COMPOSITION (%)/COMPOSICIÓN QUÍMICA (%)/CHEMISCHE ZUSAMMENSETZUNG (%)/COMPOSITION CHIMIQUE(%)

*L: Ladle C:Products

*	Heat	Seq	C	Mn	Si	P	S	Ni	Cr	Mo	Ti	N
L	57105	1	0,042	1,70	0,310	0,026	0,0010	12,30	16,70	2,17	0,363	0,0158
C	57105	1	0,042	1,68	0,350	0,026	0,0010	12,33	16,71	2,15	0,332	0,0150

HEAT TREATMENT/TRATAMIENTO TÉRMICO/WÄRMEBEHANDLUNG/TRAITEMENT THERMIQUE

HIPERTEEMPLADOS A 1100 °C , 10 min , L
SOLUTION ANNEALED AT 1100 °C , 10 min , AIR
HYPERTREMPES 1100 °C , 10 min , L
LOESUNGSGEGLUEHT 1100 °C , 10 min , Luft

TENSILE TEST/TEST DE TENSIÓN/ESSAI TRACTION/ZUGVERSUCH

Lot No	Sample	T	Rp0.2	Rp1.0	Rm	A2"	A5
		°C	MPa	MPa	MPa	%	%
Min		20	210	245	515	35	35
Max		20			690		
278597	1	20	263	293	579	48	53
	2	20	290	319	584	49	55

HARDNESS TEST/TEST DE DUREZA/DUREE/HÄRTEPRÜFUNG

Lot No	Sample	HRB
Min		
Max		90
278597	1	74
	2	73

METALURGICAL TESTS/ENSAYOS METALÚRGICOS/METALLURGISCHE PRÜFUNGEN/ESSAIS

METALLURGIQUES

INTERGRANULAR CORROSION TEST ACC. TO ASTM A262 PRACT."E": SATISFACTORY

ENSAYO DE CORROSION INTERGRANULAR DE ACUERDO A ASTM A262 PRACT.E:

SATISFACTORIO

BESTÄNDIGKEIT GEGEN INTERKRISTALLINE KORROSION ENTSPRECHEND ASTM A262

PRACT.E: IN ORDNUNG

ESSAI DE CORR. INTERGR. SELON ASTM A262 PRACT.E:SATISFAISANT

INTERGRANULAR CORROSION TEST ACC. TO DIN 50914/DIN EN ISO 3651-2 MET.A:

SATISFACTORY

ENSAYO DE CORROSION INTERGRANULAR DE ACUERDO A DIN 50914/ DIN EN ISO

3651-2 MET.A: SATISFACTORIO

BESTÄNDIGKEIT GEGEN INTERKRISTALLINE KORROSION ENTSPRECHEND DIN 50914/

DIN EN ISO 3651-2 VERF.A: IN ORDNUNG

ESSAI DE CORR. INTERGR. SELON ASTM DIN 50914/DIN EN ISO 3651-2 MET.A:

SATISFAISANT



Certified Management
System acc. to
ISO 9001, ISO 14001 and
OHSAS 18001 by LRQA

**SCHOELLER-BLECKMANN
EDELSTAHLROHR GMBH**

Riegler

FR. N. RIEGLER

(WORKS INSPECTOR)

We hereby certify that the material herein described has been manufactured, sampled, tested, and inspected in accordance with above standards and specifications and satisfies order's requirements. This certificate is issued by a computerized system and it is valid without original signature. In case the owner of the certificate would release as a copy of it, he must attest its conformity to the issued, assuming the responsibility for any unlawful or TUBACEX, not allowed use. Any forgery or falsification of this certificate shall legally prosecuted.

**NON-DESTRUCTIVE TESTS/ENSAYOS NO DESTRUCTIVOS/ZERSTÖRUNGSFREIE
PRÜFUNGEN/ESSAIS NON DESTRUCTIFS**

ULTRASCHALLPRÜFUNG NACH ISO 10893-10, U2C,
LÄNGS- UND QUERFEHLER,
AN 10 % DES LIEFERUMFANGES: IN ORDNUNG
ULTRASONIC TEST ACC. TO ISO 10893-10, U2C,
LONGITUDINAL AND TRANSVERSE DEFECTS,
AT 10% OF EXTENT OF DELIVERY: SATISFACTORY

POSITIVE MATERIAL IDENTIFICATION TEST ON EACH TUBE/PIPE BY
"X-RAY-FLUORESCENCE-ANALYZER": SATISFACTORY
VERIFICACION DEL GRADO DE ACERO EN CADA TUBO MEDIANTE
"ANALIZADOR DE FLUORESCENCIA DE RAYOS X": SATISFACTORIO
VERWECHSLUNGSPRUEFUNG AN JEDEM ROHR MIT
"RÖNTGEN-FLUORESZENZ-ANALYSATOR": IN ORDNUNG
VERIFICATION DE LA NUANCE SUR CHAQUE TUBE PAR
"X-RAY-FLUORESCENCE-ANALYZER": SATISFAISANT

HYDROSTATIC PRESSURE TESTED AT 124 bar, 1800 PSI DURING 5 SEC
ON EACH TUBE/PIPE: SATISFACTORY
ENSAYO HIDROSTÁTICO A 124 bar, 1800 PSI DURANTE 5 SEC
EN CADA TUBO: SATISFACTORIO
WASSERDRUCKPRÜFUNG BEI 124 bar, 1800 PSI HALTEZEIT 5 SEC
JE ROHR: IN ORDNUNG
ESSAI DE PRESSION HYDROSTATIQUE À 124 bar, 1800 PSI PENDANT 5 SEC
SUR CHAQUE TUBE: SATISFAISANT

**TECHNOLOGICAL TESTS/ENSAYOS TECNOLÓGICOS/TECNOLOGISCHE
PRÜFUNGEN/TECHNOLOGICAL TESTS**

FLARING TEST: SATISFACTORY
ABOCARDADO S.NORMA: SATISFACTORIO
AUFWEITVERSUCH: IN ORDNUNG
ESSAI D'EVASEMENT: SATISFAISANT

FLATTENING TEST: SATISFACTORY
APLASTADO S.NORMA: SATISFACTORIO
RINGFALTVERSUCH: IN ORDNUNG
ESSAI D'APLATISSEMENT: SATISFAISANT

THE TUBES/PIPES CONFORM ALSO TO
ANSI/NACE MR0103/ISO 17495:2015
ANSI/NACE MR0175/ISO15156-3:2015

BESICHTIGUNG UND NACHMESSUNG: IN ORDNUNG
INSPECTION AND CHECKING OF DIMENSIONS: SATISFACTORY



Certified Management
System acc. to
ISO 9001, ISO 14001 and
OHSAS 18001 by LRQA

**SCHOELLER-BLECKMANN
EDELSTAHLROHR GMBH**

Riegler

FR. N. RIEGLER

(WORKS INSPECTOR)

We hereby certify that the material herein described has been manufactured, sampled, tested, and inspected in accordance with above standards and specifications and satisfies order's requirements. This certificate is issued by a computerized system and it is valid without original signature. In case the owner of the certificate would release as a copy of it, he must attest its conformity to the issued, assuming the responsibility for any unlawful or TUBACEX, not allowed use. Any forgery or falsification of this certificate shall legally prosecuted.

**INSPECTION CERTIFICATE
CERTIFICADO DE INSPECCION
CERTIFICAT DE RECEPCION
ABNAHMEPRÜFZEUGNIS
EN 10204:2004 / 3.1**

Number: 713330
Page: 4 / 5

Rev:

Created on:
Date: 05.02.2020

Modified on:

INSPECTION ET CONTROL DES DIMENSIONS: SATISFAISANT

DIE WERKSTOFFWERTE ENSPRECHEN PUNKT 7.5 DER DRUCKGERÄTERICHTLINIE 2014/68/EU, ANHANG 1, MIT EINER BRUCHDEHNUNG VON MINDESTENS 14 % IM ZUGVERSUCH UND EINER KERBSCHLAGARBEIT VON MINDESTENS 27 J AN EINER ISO-V-KERBSCHLAGPROBE BEI 20° C.

MATERIAL CHARACTERISTICS COMPLY WITH POINT 7.5 OF ANNEX I TO PRESSURE EQUIPMENT DIRECTIVE 2014/68/EU BY HAVING AN ELONGATION AFTER RUPTURE AT TENSILE TEST NO LESS THAN 14 % AND A BENDING RUPTURE ENERGY AT IMPACT TEST NO LESS THAN 27 J AT 20°C.

MARKING/ETIQUETADO/KENNZEICHNUNG/MARKSTEXT

SCHOELLER BLECKMANN / TUBACEX GROUP - SBS 60,30 X 3,60 MM ASME SA312 ASTM A312 EN 10216-5 TC2 EN 10297-2 TP316TI 1.4571 CFD CDSMLS UT HEAT/ PMI-AV LOT NO/ MADE IN AUSTRIA T/A ZFP

REMARKS/OBSERVACIONES/ANMERKUNG/REMARQUES

TENSILE TEST WAS PERFORMED ON LONGITUDINAL STRIP SPECIMEN WITH GAUGE WIDTH 12,7 MM

ZUGVERSUCH WURDE DURCHGEFÜHRT AN LÄNGSORIENTIERTEN STREIFENPROBEN MIT EINER PROBENBREITE VON 12,7 MM

MECHANICAL TESTS WERE PERFORMED IN LONGITUDINAL DIRECTION IF NOT OTHERWISE STATED.

REALIZADOS TEST MECÁNICOS EN DIRECCIÓN LONGITUDINAL SI NO HAY OTRAS INSTRUCCIONES.

DIE MECHANISCHEN PRÜFUNGEN WURDEN, SOWEIT NICHT ANDERS ANGEGEBEN, IN LÄNGSRICHTUNG DURCHGEFÜHRT.

LES ESSAIS MÉCANIQUES ONT ÉTÉ FAITS, SI PAS SPÉCIFIÉ, EN DIRECTION LONGITUDINALE.

NO WELD REPAIR HAS BEEN PERFORMED ON THE MATERIAL.

SIN REPARACION POR SOLDADURA

AM MATERIAL WURDE NICHT GESCHWEISST.

SANS RÉPARATION AVEC SOUDURE

MATERIAL MANUFACTURER APPROVED WITH CERTIFICATE NR. 245/2004/MUC BY TÜV SÜDDEUTSCHLAND (NOTIFIED BODY 0036) TO ISSUE CERTIFICATES OF SPECIFIC PRODUCT CONTROL IN ACCORDING TO PRESSURE EQUIPMENT DIRECTIVE 2014/68/EU.



Certified Management
System acc. to
ISO 9001, ISO 14001 and
OHSAS 18001 by LRQA

We hereby certify that the material herein described has been manufactured, sampled, tested, and inspected in accordance with above standards and specifications and satisfies order's requirements. This certificate is issued by a computerized system and it is valid without original signature. In case the owner of the certificate would release as a copy of it, he must attest its conformity to the issued, assuming the responsibility for any unlawful or TUBACEX, not allowed use. Any forgery or falsification of this certificate shall legally prosecuted.

**SCHOELLER-BLECKMANN
EDELSTAHLROHR GMBH**

Riegler

FR. N. RIEGLER

(WORKS INSPECTOR)

REMARKS/OBSERVACIONES/ANMERKUNG/REMARQUES

FABRICANTE DE MATERIALES APROBADO CON CERTIFICADO N° 245/2004/MUC EMITIDOPOR TUV SUDDEUTSCHLAND (ORGANISMO NOTIFICADO 0036) PARA LA EMISION DE CERTIFICADOS ESPECIFICOS DE CONTROL DE PRODUCTO DE ACUERDO DE LA DIRECTIVA DE EQUIPOS A PRESION 2014/68/EU.

WERKSTOFFHERSTELLER MIT BERECHTIGUNG ZUR AUSSTELLUNG VON BESCHEINIGUNGEN ÜBER SPEZIFISCHE PRÜFUNGEN AN DEN WERKSTOFFEN IM GELTUNGSBEREICH DER ZERTIFIZIERUNG UND IN ÜBEREINSTIMMUNG MIT DER DRUCKGERÄTERICHTLINIE 2014/68/EU UND DEN ZUGRUNDE LIEGENDEN SPEZIFIKATIONEN ENTSPR. ZERTIFIKAT NR. 245/2004/MUC DER BENANNTEN STELLE NR.0036, TÜV SÜDDEUTSCHLAND

PRODUCTEUR DU MATERIEL APPROUVE SOUS CERTIFICATION N° 245/2004/MUC PAR TUV SUDDEUTSCHLAND (N.B. 0036) POUR EMISSION DES CERTIFICATS SPECIFIQUE DE CONTROLE DE PRODUIT SELON LA DIRECTIVE DES EQUIPES A PRESION 2014/68/EU.

MATERIAL IS FREE OF RADIOACTIVE CONTAMINATION
EL MATERIAL ESTA LIBRE DE CONTAMINACION POR RADIACIONES
MATERIAL IST FREI VON RADIOAKTIVITÄT
MATÉRIEL LIBRE DE POLUTION RADIOACTIVE

REMARKS/COMENTARIOS/BEMERKUNG/REMARQUES

Im Einvernehmen mit dem TÜV-Bayern (Juli 1959).

In accordance with / en accord avec TÜV-Bayern (Juli 1959)

Auf eine Gegenzeichnung durch die zuständige Technische Überwachungs-Organisation kann auf Grund des Schreibens des TÜV-Bayern vom 23.6.1969 verzichtet werden.



Certified Management
System acc. to
ISO 9001, ISO 14001 and
OHSAS 18001 by LRQA

We hereby certify that the material herein described has been manufactured, sampled, tested, and inspected in accordance with above standards and specifications and satisfies order's requirements. This certificate is issued by a computerized system and it is valid without original signature. In case the owner of the certificate would release as a copy of it, he must attest its conformity to the issued, assuming the responsibility for any unlawful or TUBACEX, not allowed use. Any forgery or falsification of this certificate shall legally prosecuted.

**SCHOELLER-BLECKMANN
EDELSTAHLROHR GMBH**

Riegler

FR. N. RIEGLER

(WORKS INSPECTOR)

A02 Inspection certificate "3.1" (EN 10 204)

A03 Document No.: 66652/20

Page: 1/1

A07	Customer's Order (P.O.) No./Item No.: 4500762205							A08	Manufacturer's Works Order No.: 32238/0/20							
A11	Supplier's Order No.: 3151013637							A10	Advice - Note No.: 8150062157							
B08, B12/13	Quantity delivered:			B13 Actual mass				A06	Customer / Consignee:							
	pcs	mtrs		kg				<div style="border: 1px solid black; padding: 10px; text-align: center;"> Onninen OY Mittalinja 1 01260 Vantaa Finland </div>								
	bcls	feet		lbs												
	87	522,000		2999												
B09-11	Dimensions: 60,3 x 4,00 mm															
B02	Steel designation: P235GH															
B01, B03, B04	Product, conditions and terms of delivery: Seamless steel tubes, EN 10220/2002, EN 10216-2/13 TC1- AD-2000 Merkblatt W4/2013, PED 2014/68/EU (TÜV NORD), TRD 102-6/98, TRB 100-2/95. Normalized hot finished.															
A04, B06	Marking: Manufacturer's mark, mill inspector's stamp <div style="display: flex; justify-content: space-around; align-items: center;"> LO <div style="border: 1px solid black; border-radius: 50%; padding: 5px; text-align: center; width: 30px; height: 30px; display: flex; align-items: center; justify-content: center;">2</div> </div>															
C71-92	Heat chemical analysis (%)							C70	Steel made by basic oxygen process, fully killed, strand cast.							
B07	Heat No.:	C	MN	SI	P	S	CU	NI	CR	Alt	MO					
	28227K	0,08	0,56	0,235	0,011	0,008	0,09	0,04	0,05	0,030	0,006					
Z99	<input type="checkbox"/>															
B07	Test results:		MPa		MPa		% (5d)		C40-43 Impact test			C30-32 Hardness				
C04	Heat No.	Specimen No.	C11 Yield Point		C12 Tensile Strength		C13 Elongation		Ø			min				
	28227K	P235GH	min. 235		360- 500		min. 25									
Z99	<input type="checkbox"/>															
D01	Visual and dimensional inspection with satisfactory results							X	D51	Hydrostatic test - min. test pressure						
C50	Flattening test (EN ISO 8492) - satisfactory							X	D02	The pipes tested on tightness by NDT flux - leakage in acc. to EN ISO 10893-1/11						
C51	Expanding test (EN ISO 8493) - satisfactory								Rotomat HS - typ 6.717.51							
C52	Bending test (EN ISO 8491) - satisfactory															
C53	Ring expanding test (EN ISO 8495) - satisfactory							X	D03	Nondestructive Electromagnetic Testing						
C54	Ring tensile test (EN ISO 8496) - satisfactory															
The manufacturer has an established and certified management system according to ISO 9001:2015, ISO 14001:2015, ISO 50001:2011, ISO 45001:2018. PED 2014/68/EU and AD 2000-Merkblatt W0 certified by TÜV NORD, cert. No. 0045/202/9190/WZ/0807/18(02) and 07-203-9190-WP-0807/18(02). Impact strength is guaranteed on the basis of statistical data evaluation (28J/-10°C).																
Z01	All pipes conform to the above mentioned standards and ordering requirements and agreements.															

Z02 Date of issue 8.9.2020/KA

Tel.:+420 595683644

A01 Liberty Ostrava a.s.
A05 QA Department
Vratimovská 689/117
719 00 Ostrava-Kunčice
Czech Republic

Liberty Ostrava a.s.
 Vratimovská 689/117, 719 00 Ostrava - Kunčice
 Rourovny



Bc. Petr Pastucha

Work's Inspector
Z02 Validation

INSPECTION CERTIFICATE ABNAHMEPRUEFZEUGNIS (UNI EN 10204 3.1 / ISO 10474 3.1)	Number / Nummer: 01-20-09274	Page / Seite: 1 / 9
Date / Datum: September 25, 2020		

Customer / Kunde: DYLAN STAAL NETHERLANDS B.V.		Customer's Order Item / Kunden Bestell-Nr.: PO-20-DS02531	Customer's Reference / Kunden Referenz-Nr.:	Manufacturer's Works Order N° / Auftrags-Nr.: 1263074/001
Manufacturing Process / Herstellungsprozess: NORMALIZED NORMALGEGLUEHT		Product Type / Art des Produkts: See note nr.1 Sehen Sie Anmerkung nr.1		Surface / Oberfläche: BARE INSIDE, EXTERNALLY PROTECTED BY VARNISH INNEN ROH, AUSSEN GEOELT
Standard or Specification / Norm oder Spezifikation: ACCORDING TO THE NORM EN 10216-2 TC1, PED, AD2000 W4 + TQ 20037055/3.1 GEM. DIN EN 10216-2 TC1, PED, AD2000 W4 + TQ 20037055/3.1		Steel Grade / Werkstoff: STEEL P235GH TC1 STAHL P235GH TC1		Ends / Enden: PLAIN END (SQUARE CUT) GLATTEN ENDEN
Dimensions / Abmessung: ø 14,000" O.D. x .315" W.T. ø 355.60mm O.D. x 8.00mm W.T.	Schedule / Schedule:	Length / Laenge: 16.404 ft ± 22.966 ft 5000 mm ± 7000 mm	Quantity / Menge: 30Pcs/Pz 619'05" ft 30093 lb 188.81 mt 13650 kg	Nominal Weight / Theor. Gewicht: 46.08 lb/ft 68.57 Kg/m

DELIVERY NOTES / LIEFERSCHEINE

Delivery Notes Lieferscheine	Delivery Notes Lieferscheine
Job Number: 0031271455 / 000010 Shipping note: 0102107393 - 00/00/0000 Address: JAN VAN DER HEIJDENSTRAAT	Town: 3261 OUD BEIJERLAND Country: The Netherlands

TENSILE TEST / ZUGVERSUCH

Heat N° Charge Nr.	Sample N° Probe Nr.	Lot N° Los Nr.	Specimen condition Probenform				Specimen dimensions Probengroesse			Test temp temper	Y.S.		U.T.S.		Elongation / Bruchdehnung			
			Ls	Sc	Type	On	Size abmessung	Area Flaeche	°C		ReH	Req.	Lo	Min.	Min.	Obt.		
											Min: 235.00	Max: 480.00					5D = 5.65/So	cal.
902651	R1472	1	B	N	Ss	L	19.80 x 8.49	168.20	+20	303.00	414.00	5D	75.0	25.0%	36.0%			
909201	R1470/C	1	B	N	Ss	L	21.12 x 8.17	172.70	+20	313.00	420.00	5D	75.0	25.0%	33.5%			

B: Body / Koerper	Max: Maximum / Maximal	Ort: Orientation / Richtung	U.T.S: Ultimate Tensile Strength / Aeusserste
L: Longitudinal / Laenge	Min: Minimum / Minimal	Req: Required / Gefordert	Streckgrenze
Lo: Initial length / Anfangslaenge	N: Normalized / Normalisiert	Sc: Specimen condition / Probenzustand	Y.S: Yield Strength / Streckgrenze
Ls: Location of sample / Probenentnahme	Obt: Obtained / Erhalten	Ss: Strip specimen / Streifenprobe	

This certificate is issued by a computerized system and it is valid with electronic signature. On the original certificate the trade-mark green colored "Tenaris" is stamped. In case the owner of the original certificate would release a copy of it, he must attest its conformity to the original one taking upon himself the responsibility for any unlawful or not allowed use. Any alteration and/or falsification will be subjected to the law.

Dieses Zeugnis wird mittels eines Computersystems erstellt und ist mit elektronischer Unterschrift gegueltig. Das Originaldokument ist durch das Tenaris Logo in gruene Farbe erkennbar. Beim Erstellen einer Kopie des Originalzeugnisses, muss der Eigentümer des Zeugnisses sicherstellen, dass die Kopie dem Original entspricht. Verantwortlich fuer eine unauthorisierte oder unrichtige Benutzung uebernehmen. Jegliche Aenderungen oder Faelshungen kann strafrechtlich verfolgt werden.

INSPECTION CERTIFICATE
ABNAHMEPRUEFZEUGNIS
(UNI EN 10204 3.1 / ISO 10474 3.1)

Number / Nummer: **01-20-09274** Page / Seite: **2 / 9**
Date / Datum: **September 25, 2020**

Customer / Kunde: DYLAN STAAL NETHERLANDS B.V.		Customer's Order Item / Kunden Bestell-Nr.: PO-20-DS02631	Customer's Reference / Kunden Referenz-Nr.:	Manufacturer's Works Order N° / Auftrags-Nr.: 1263074/001
Manufacturing Process / Herstellungsprozess: NORMALIZED NORMALGEGLUEHT		Product Type / Art des Produkts: See note nr.1 Sehen Sie Anmerkung nr.1		Surface / Oberflaeche: BARE INSIDE, EXTERNALLY PROTECTED BY VARNISH INNEN ROH, AUSSEN GEOELT
Standard or Specification / Norm oder Spezifikation: ACCORDING TO THE NORM EN 10216-2 TC1, PED, AD2000 W4 + TQ 20037055/3.1 GEM. DIN EN 10216-2 TC1, PED, AD2000 W4 + TQ 20037055/3.1		Steel Grade / Werkstoff: STEEL P235GH TC1 STAHL P235GH TC1		Ends / Enden: PLAIN END (SQUARE CUT) GLATTEN ENDEN
Dimensions / Abmessung: ø 14,000" O.D. x .315" W.T. ø 355.60mm O.D. x 8.00mm W.T.	Schedule / Schedule:	Length / Länge: 16,404 ft + 22,965 ft 5000 mm + 7000 mm	Quantity / Menge: 30Pcs/Pz 61905" ft 30093 lb 188.81 mt 13550 kg	Nominal Weight / Theor. Gewicht: 46,08 lb/ft 68.57 Kg/m

CHEMICAL COMPOSITION / CHEMISCHE ZUSAMMENSETZUNG

		Composition % / Zusammensetzung %																					
		X 100								X 1000													
		C	Mn	Si	Ni	Cr	Mo	Cu	F1	P	S	Sn	Al	Ti	Nb	V	N						
Heat N°	Max	18	80	35	30	30	8	30	70	25	10	--	--	40	10	20	--						
	Min	--	40	10	--	--	--	--	--	--	--	--	20	--	--	--	--						
Sample N°	Max	16	80	35	30	30	8	30	70	25	13	--	--	40	10	20	--						
	Min	--	40	10	--	--	--	--	--	--	--	--	20	--	--	--	--						
Charge Nr.	Probe Nr.	Zone	Lot N°	Los Nr.	H	9	46	19	13	21	5	16	55	14	3	12	26	1	1	4	66		
					P	10	44	18	13	22	5	16	56	13	3	10	28	1	2	1	1	69	
					H	9	54	19	13	21	5	16	55	14	3	12	26	1	1	1	1	8	66
					P	10	52	18	13	22	5	18	58	13	2	11	24	1	2	5	5	64	

F1: (Cr+Cu+Mo+Ni) Max: Maximum / Maximal P: Product / Produkt
H: Heat / Charge Min: Minimum / Minimal

IMPACT TEST / KERBSCHLAGPROBE

Type/Typ: ISOV		Orientation/Richtung: T				Unit / Einheit: JOULE															
Position/Position:		Temp: - 20	Unit/Einheit: °C	Ind. Min. Req: 9	Req. Min. Avg: 14	Position/Position:		Temp: - 20	Unit/Einheit: °C	Ind. Min. Req: 9	Req. Min. Avg: 14										
Heat N°	Sample N°	Zone	Lot N°	Zone	Los Nr.	Size / Abmessung	Results / Ergebnis	Heat N°	Sample N°	Zone	Lot N°	Zone	Los Nr.	Size / Abmessung	Results / Ergebnis						
Charge Nr.	Probe Nr.	Zone	Los Nr.	Zone	Los Nr.	mm	1	2	3	Avg.	Charge Nr.	Probe Nr.	Zone	Los Nr.	Zone	Los Nr.	mm	1	2	3	Avg.
902651	R1472	outside	1	B	N	10 x 5.00	154.0	170.0	164.0	166.0	909201	R1470/C	outside	1	B	N	10 x 5.00	99.0	107.0	102.0	103.0

Avg: Average / Mittelwert mindestens gef. Einzelwert Req. Min. Avg: Required minimum average / T: Transversal / Quer

This certificate is issued by a computerized system and it is valid with electronic signature. On the original certificate the trade-mark green colored "Tenaris" is stamped. In case the owner of the original certificate would release a copy of it, he must attest its conformity to the original one taking upon himself the responsibility for any unlawful or not allowed use. Any alteration and/or falsification will be subjected to the law.

Dieses Zeugnis wird mittels eines Computersystems erstellt und ist mit elektronischer Unterschrift gültig. Das Originalattest ist durch das Tenaris Logo in grüner Farbe gekennzeichnet. Beim Erstellen einer Kopie des Originalattests, muss der Eigentümer des Zeugnisses sicherstellen, dass die Kopie dem Original entspricht. Verantwortung über eine unzulässige oder unrichtige Benutzung übernehmen. Jegliche Änderungen oder Fälschungen kann strafrechtlich verfolgt werden.

INSPECTION CERTIFICATE ABNAHMEPRUEFZEUGNIS (UNI EN 10204 3.1 / ISO 10474 3.1)	Number / Nummer: 01-20-09274	Page / Seite: 3 / 9
Date / Datum: September 25, 2020		

Customer / Kunde: DYLAN STAAL NETHERLANDS B.V.		Customer's Order Item / Kunden Bestell-Nr.: PO-20-DS02631	Customer's Reference / Kunden Referenz-Nr.:	Manufacturer's Works Order N° / Auftrags-Nr.: 1263074/001
Manufacturing Process / Herstellungsprozess: NORMALIZED NORMALGEGLUEHT		Product Type / Art des Produkts: See note nr.1 Sehen Sie Anmerkung nr.1		Surface / Oberfläche: BARE INSIDE, EXTERNALLY PROTECTED BY VARNISH INNEN ROH, AUSSEN GEOELT
Standard or Specification / Norm oder Spezifikation: ACCORDING TO THE NORM EN 10216-2 TC1, PED, AD2000 W4 + TQ 20037055/3.1 GEM. DIN EN 10216-2 TC1, PED, AD2000 W4 + TQ 20037055/3.1		Steel Grade / Werkstoff: STEEL P235GH TC1 STAHL P235GH TC1		Ends / Enden: PLAIN END (SQUARE CUT) GLATTEN ENDEN
Dimensions / Abmessung: ø 14.000" O.D. x .315" W.T. ø 355.60mm O.D. x 8.00mm W.T.	Schedule / Schedule:	Length / Länge: 16.404 ft + 22.966 ft 5000 mm + 7000 mm	Quantity / Menge: 30093 lb 13650 kg	Nominal Weight / Theor. Gewicht: 46.08 lb/ft 68.57 Kg/m

IMPACT TEST / KERBSCHLAGPROBE

B: Body / Koerper	Ls: Location of sample / Probenentnahme	mindestens gef. Mittelwert	Temp: Temperature / Temperatur
Ind. Min. Req: Individual Minimum Required /	N: Normalized / Normalisiert	Sc: Specimen condition / Probenzustand	

Type/Typ: ISOV		Orientation/Richtung: T				Unit / Einheit: JOULE					
Position/Position:		Temp: - 40		Unit/Einheit: °C		Ind.Min.Req: --		Req.Min.Avg: --			
Heat N°	Sample N°	Zone	Lot N°	Size / Abmessung		Results / Ergebnis					
Charge Nr.	Probe Nr.	Zone	Los Nr.	Ls	Sc	mm		1	2	3	Avg.
902651	R1472	outside	1	B	N	10 x 5.00		122.0	155.0	142.0	140.0

Avg: Average / Mittelwert	mindestens gef. Einzelwert	Req. Min. Avg: Required minimum average /	T: Transversal / Quer
B: Body / Koerper	Ls: Location of sample / Probenentnahme	mindestens gef. Mittelwert	Temp: Temperature / Temperatur
Ind. Min. Req: Individual Minimum Required /	N: Normalized / Normalisiert	Sc: Specimen condition / Probenzustand	

Type/Typ: ISOV		Orientation/Richtung: T				Unit / Einheit: JOULE					
Position/Position:		Temp: - 50		Unit/Einheit: °C		Ind.Min.Req: --		Req.Min.Avg: --			
Heat N°	Sample N°	Zone	Lot N°	Size / Abmessung		Results / Ergebnis					
Charge Nr.	Probe Nr.	Zone	Los Nr.	Ls	Sc	mm		1	2	3	Avg.
902651	R1472	outside	1	B	N	10 x 5.00		141.0	175.0	179.0	163.0

Avg: Average / Mittelwert	mindestens gef. Einzelwert	Req. Min. Avg: Required minimum average /	T: Transversal / Quer
B: Body / Koerper	Ls: Location of sample / Probenentnahme	mindestens gef. Mittelwert	Temp: Temperature / Temperatur
Ind. Min. Req: Individual Minimum Required /	N: Normalized / Normalisiert	Sc: Specimen condition / Probenzustand	

This certificate is issued by a computerized system and it is valid with electronic signature. On the original certificate the trade-mark green colored "Tenaris" is stamped. In case the owner of the original certificate would release a copy of it, he must attest its conformity to the original one taking upon himself the responsibility for any unlawful or not allowed use. Any alteration and/or falsification will be subjected to the law.

Dieses Zeugnis wird mittels eines Computersystems erstellt und ist mit elektronischer Unterschrift gültig. Das Originalzeugnis ist durch das Tenaris Logo in grün Farbe erkennlich. Beim Erstellen einer Kopie des Originalzeugnisses, muss der Eigentümer des Zeugnisses sicherstellen, dass die Kopie dem Original entspricht. Verantwortlich für eine ungesetzliche oder unrichtliche Benutzung übernehmen. Jegliche Änderungen oder Fälschungen kann strafrechtlich verfolgt werden.

INSPECTION CERTIFICATE ABNAHMEPRUEFZEUGNIS (UNI EN 10204 3.1 / ISO 10474 3.1)	Number / Nummer: 01-20-09274	Page / Seite: 4 / 9
Date / Datum: September 25, 2020		

Customer / Kunde: DYLAN STAAL NETHERLANDS B.V.		Customer's Order Item / Kunden Bestell-Nr.: PO-20-DS02531		Customer's Reference / Kunden Referenz-Nr.:		Manufacturer's Works Order N° / Auftrags-Nr.: 1263074/001	
Manufacturing Process / Herstellungsprozess: NORMALIZED NORMALGEGLUHT		Product Type / Art des Produkts: See note nr.1 Sehen Sie Anmerkung nr.1		Surface / Oberfläche: BARE INSIDE, EXTERNALLY PROTECTED BY VARNISH INNEN ROH, AUSSEN GEOELT			
Standard or Specification / Norm oder Spezifikation: ACCORDING TO THE NORM EN 10216-2 TC1, PED, AD2000 W4 + TQ 20037055/3.1 GEM. DIN EN 10216-2 TC1, PED, AD2000 W4 + TQ 20037055/3.1				Steel Grade / Werkstoff: STEEL P235GH TC1 STAHL P235GH TC1		Ends / Enden: PLAIN END (SQUARE CUT) GLATTEN ENDEN	
Dimensions / Abmessung: ø 14.000" O.D. x .315" W.T. ø 355.60mm O.D. x 8.00mm W.T.		Schedule / Schedule:		Length / Laenge: 16.404 ft + 22.966 ft 5000 mm + 7000 mm		Quantity / Menge: 30Pcs/Pz	
				619'05" ft 30093 lb 188.81 mt 13650 kg		Nominal Weight / Theor. Gewicht: 46.08 lb/ft 68.57 Kg/m	

FLATTENING TEST / faltversuch

Standard / Standard:							Standard / Standard:						
Heat N° Charge Nr.	Lot N° Los Nr.	Sample N° Probe Nr.	Zone Zone	Sc	Test Frequency Probenfrequenz	Result Ergebnis	Heat N° Charge Nr.	Lot N° Los Nr.	Sample N° Probe Nr.	Zone Zone	Sc	Test Frequency Probenfrequenz	Result Ergebnis
909201	1	R1469	E1	N	1 pipe of the lot	Good / Gut	902651	1	R1471/C	E1	N	1 pipe of the lot	Good / Gut

E1 / E2: Ends of Sampling / Probenende N: Normalized / Normalisiert Sc: Specimen condition / Probenzustand

RING TENSILE TEST / RINGZUGVERSUCH

Standard / Standard:							Standard / Standard:						
Heat N° Charge Nr.	Lot N° Los Nr.	Sample N° Probe Nr.	Zone Zone	Sc	Test Frequency Probenfrequenz	Result Ergebnis	Heat N° Charge Nr.	Lot N° Los Nr.	Sample N° Probe Nr.	Zone Zone	Sc	Test Frequency Probenfrequenz	Result Ergebnis
909201	1	R1469	E1	N	1 pipe of the lot	Good / Gut	902651	1	R1471/C	E1	N	1 pipe of the lot	Good / Gut

E1 / E2: Ends of Sampling / Probenende N: Normalized / Normalisiert Sc: Specimen condition / Probenzustand

This certificate is issued by a computerized system and it is valid with electronic signature. On the original certificate the trade-mark green colored "Tenaris" is stamped. In case the owner of the original certificate would release a copy of it, he must attest its conformity to the original one taking upon himself the responsibility for any unlawful or not allowed use. Any alteration and/or falsification will be subjected to the law.

Dieses Zeugnis wird mittels eines Computersystems erstellt und hat mit elektronischer Unterschrift gültig. Das Originalzeugnis ist durch das Tenaris Logo in grün farbig gekennzeichnet. Beim Erstellen einer Kopie des Originalzeugnisses, muss der Eigentümer des Zeugnisses sicherstellen, dass die Kopie dem Original entspricht. Verantwortlich für eine unzulässige oder unrechtmäßige Benutzung, übernehmen. Jegliche Änderungen oder Fälschungen, kann strafrechtlich verfolgt werden.

INSPECTION CERTIFICATE ABNAHMEPRUEFZEUGNIS (UNI EN 10204 3.1 / ISO 10474 3.1)	Number / Nummer: 01-20-09274	Page / Seite: 5 / 9
Date / Datum: September 25, 2020		

Customer / Kunde: DYLAN STAAL NETHERLANDS B.V.		Customer's Order Item / Kunden Bestell-Nr.: PO-20-DS02531		Customer's Reference / Kunden Referenz-Nr.:		Manufacturer's Works Order N° / Auftrags-Nr.: 1263074/001	
Manufacturing Process / Herstellungsprozess: NORMALIZED NORMALGEGLUEHT		Product Type / Art des Produkts: See note nr.1 Sehen Sie Anmerkung nr.1				Surface / Oberfläche: BARE INSIDE, EXTERNALLY PROTECTED BY VARNISH INNEN ROH, AUSSEN GEOELT	
Standard or Specification / Norm oder Spezifikation: ACCORDING TO THE NORM EN 10216-2 TC1, PED, AD2000 W4 + TQ 20037055/3.1 GEM. DIN EN 10216-2 TC1, PED, AD2000 W4 + TQ 20037055/3.1				Steel Grade / Werkstoff: STEEL P235GH TC1 STAHL P235GH TC1		Ends / Enden: PLAIN END (SQUARE CUT) GLATTEN ENDEN	
Dimensions / Abmessung: ø 14.000" O.D. x .315" W.T. ø 355.60mm O.D. x 8.00mm W.T.		Schedule / Schedule:		Length / Laenge: 16.404 ft + 22.966 ft 5000 mm + 7000 mm		Quantity / Menge: 30Pcs/Pz 619'05" ft 30093 lb 188.81 mt 13660 kg	
						Nominal Weight / Theor. Gewicht: 46.08 lb/ft 65.57 Kg/m	

METALLOGRAPHIC TEST / METALLOGRAFISCHE PRUEFUNG

Heat N° Charge Nr.	Sample N° Probe Nr.	Lot N° Los Nr.	Ls	Grain Size / Koernung		Microstructure / Mikrostruktur
				Standard / Standard: ASTM E112	Method / Methode: Microscopico	Required / Getordert:
				Unit / Einheit: N	Minimum / Minimal: --	Maximum / Maximal: --
909201	R1470/C	1	B	11.0	11.0	FERRITE AND PEARLITE
902651	R1472	1	B	9.0	9.0	FERRITE AND PEARLITE

B: Body / Koerper Ls: Location of sample / Probenentnahme N: Number / Nummer

This certificate is issued by a computerized system and it is valid with electronic signature. On the original certificate the trade-mark green colored "Tenaris" is stamped. In case the owner of the original certificate would release a copy of it, he must attest its conformity to the original one taking upon himself the responsibility for any unlawful or not allowed use. Any alteration and/or falsification will be subjected to the law.

Dieses Zeugnis wird mittels eines Computersystems erstellt und ist mit elektronischer Unterschrift gultig. Das Originalzeugnis ist durch das Tenaris Logo in gru Farbe erkennlich. Beim Erstellen eines Kopie des Originalzeugnisses, muss der Eigenhuer der des Zeugnisses sicherstellen, dass die Kopie dem Original entspricht. Verantwortung fuer eine ungesetzmaessige oder unrechtlche Benutzung uebernehmen. Jegliche Aenderung oder Faelschung kann strafrechtlich verfolgt werden.

INSPECTION CERTIFICATE ABNAHMEPRUEFZEUGNIS (UNI EN 10204 3.1 / ISO 10474 3.1)	Number / Nummer: 01-20-09274	Page / Seite: 6 / 9
Date / Datum: September 25, 2020		

Customer / Kunde: DYLAN STAAL NETHERLANDS B.V.		Customer's Order Item / Kunden Bestell-Nr.: PO-20-DS02531		Customer's Reference / Kunden Referenz-Nr.:		Manufacturer's Works Order N° / Auftrags-Nr.: 1263074J001	
Manufacturing Process / Herstellungsprozess: NORMALIZED NORMALGEGLUHEIT		Product Type / Art des Produkts: See note nr.1 Sehen Sie Anmerkung nr.1		Surface / Oberfläche: BARE INSIDE, EXTERNALLY PROTECTED BY VARNISH INNEN ROH, AUSSEN GEOELT		Ends / Enden: PLAIN END (SQUARE CUT) GLATTEN ENDEN	
Standard or Specification / Norm oder Spezifikation: ACCORDING TO THE NORM EN 10216-2 TC1, PED, AD2000 W4 + TQ 20037055/3.1 GEM. DIN EN 10216-2 TC1, PED, AD2000 W4 + TQ 20037055/3.1		Steel Grade / Werkstoff: STEEL P235GH TC1 STAHL P235GH TC1		Quantity / Menge: 30Pcs/Pz		Nominal Weight / Theor. Gewicht: 46.08 lb/ft 68.57 Kg/m	
Dimensions / Abmessung: ø 14.000" O.D. x .315" W.T. ø 355.60mm O.D. x 8.00mm W.T.		Schedule / Schedule: 16.404 ft + 22.966 ft 5000 mm + 7000 mm		619'05" ft 188.81 mt		30093 lb 13650 kg	

SUPPLEMENTARY INFORMATION / ZUSAETZLICHE INFORMATIONEN

STANDARD EDITIONS AUSGABE NACH			
Standards: EN 10216-2	Year: 2014	Revision: 2019	Revision year:
Standards: EN 10216-2	Year: 2014	New edition: 2019	New edition year:

PRODUCT DESCRIPTION NOTES PRODUKT-BESCHREIBUNGS-ANMERKUNGEN	
Note 1 is the full description of the "Product type" SEAMLESS HOT FINISHED STEEL TUBES FOR BOILERS (WITH EXTRA REQUIREMENTS)	Anmerkung 1 ist die volle Beschreibung der "Art des Produkts" NAHTLOSE QUALITAETSTAHLROHRE WARMBEFERTIGT ALS KESSELROHRE (MIT ZUSATZLICHEN ANFORDERUNGEN)

Supplementary Information Zusaetzliche Informationen	
Country of melt: ITALY Continuous casting and fully killed MATERIAL ACCORDING TO AD2000W4	Country of melt: ITALY Continuous casting and fully killed MATERIAL ACCORDING TO AD2000W4

Supplementary Information Zusaetzliche Informationen	
DALMINE OPERATES A QUALITY MANAGEMENT SYSTEM CERTIFIED BY LLOYD'S REGISTER NR. LRC 110956/QMS/U/EN/001, AND IT HAS UNDERGONE A SPECIFIC ASSESSMENT SUPPORTING THE REQUIREMENTS OF ANNEX 1 SECT 4.3 OF "PRESSURE EQUIPMENT DIRECTIVE (PED) 2014/68/EU". INSPECTION CERTIFICATE ISSUED IN AGREEMENT WITH T.U.V. SUD INDUSTRIE SERVICE GMBH, QMS APPROVED ACCORDING TO ANNEX 1 PAR. 4.3 OF PRESSURE EQUIPMENT DIRECTIVE 2014/68/EU BY NOTIFIED BODY 0036. CERTIFICATION NO. LIR-0036-05-W 200/2003/MAC. AFTER INSPECTION OPERATION, THE MATERIAL HAD NOT A RESIDUAL MAGNETISM	DAS DALMINE QUALITAETSMANAGEMENTSYSTEM IS DURCH LLOYD'S REGISTER NR. LRC 110956/QMS/U/EN/001, ZERTIFIZIERT UND ENTSPICHT DEN ANFORDERUNGEN GEMASS ANHANG 1 ABSCHNITT 4.3 DER PED 2014/68/EU, INSPEKTION ZERTIFIKAT IN VEREINBARUNG MIT TUV SUD INDUSTRIE SERVICE GMBH, QMS NACH ANHANG 1 PAR. 4.3 DER DRUCKAUSRUESTUNGSRICHTLINIE 2014/68 / ES VON BENANNETER BEURTEILER ZUGELASSEN 0036, ZERTIFIKATION NR. LIR-0036-05-W 200/2003/MAC. NACH DER KONTROLLE IST DER RESTMAGNETISMUS NICHT GROSSER ALS 20 GAUSS. ALLE ROHRE WURDEN DURCH ELEKTROMAGNETISCHE PRUEFUNG NACH SPEZ.

This certificate is issued by a computerized system and it is valid with electronic signature. On the original certificate the trade-mark green colored "Tenaris" is stamped. In case the owner of the original certificate would release a copy of it, he must attest its conformity to the original one taking upon himself the responsibility for any unlawful or not allowed use. Any alteration and/or falsification will be subjected to the law.	Dieses Zeugnis wird mittels eines Computersystems erstellt und ist mit elektronischer Unterschrift gueltig. Das Originalattest ist durch das Tenaris Logo in gr. Farbe erkennlich. Beim Erstellen einer Kopie des Originalattests, muss der Eigentümer des Zeugnisses sicherstellen, dass die Kopie dem Original entspricht. Verantwortlich fuer eine ungesetzmassene oder unrechtlliche Benützung uebernehmen. Jegliche Aenderung oder Falschung kann strafrechtlich verfolgt werden!
---	--

INSPECTION CERTIFICATE ABNAHMEPRUEFZEUGNIS (UNI EN 10204 3.1 / ISO 10474 3.1)	Number / Nummer: 01-20-09274	Page / Seite: 7 / 9
Date / Datum: September 25, 2020		

Customer / Kunde: DYLAN STAAL NETHERLANDS B.V.		Customer's Order Item / Kunden Bestell-Nr.: PO-20-DS02531		Customer's Reference / Kunden Referenz-Nr.:		Manufacturer's Works Order N° / Auftrags-Nr. 1263074/001	
Manufacturing Process / Herstellungsprozess: NORMALIZED NORMALGEGLUEHT		Product Type / Art des Produkts: See note nr.1 Sehen Sie Anmerkung nr.1		Surface / Oberfläche: BARE INSIDE, EXTERNALLY PROTECTED BY VARNISH INNEN ROH, AUSSEN GEOELT			
Standard or Specification / Norm oder Spezifikation: ACCORDING TO THE NORM EN 10216-2 TC1, PED, AD2000 W4 + TQ 20037055/3.1 GEM. DIN EN 10216-2 TC1, PED, AD2000 W4 + TQ 20037055/3.1				Steel Grade / Werkstoff: STEEL P235GH TC1 STAHL P235GH TC1		Ends / Enden: PLAIN END (SQUARE CUT) GLATTEN ENDEN	
Dimensions / Abmessung: ø 14.000" O.D. x .315" W.T. ø 355.60mm O.D. x 8.00mm W.T.		Schedule / Schedule: 16.404 ft + 22.966 ft 5000 mm + 7000 mm		Quantity / Menge: 30Pcs/Pz 619'05" ft 30093 lb 188.81 mt 13650 kg		Nominal Weight / Theor. Gewicht: 46.08 lb/ft 66.57 Kg/m	

SUPPLEMENTARY INFORMATION / ZUSÄTZLICHE INFORMATIONEN

Supplementary Information Zusätzliche Informationen	
<p>GREATER THAN 20 GAUSS ALL PIPES HAVE BEEN TESTED BY EDDY-CURRENT TEST ACCORDING TO SPEC. EN ISO 10693-1, WITH SATISFACTORY RESULT ALL PIPES HAVE BEEN NORMALIZED AT 920 °C FOR 10 MINS. AND COOLED IN STILL AIR THE ENDS (FOR 300 mm) HAVE BEEN TESTED WITH WET FLUORESCENT MAGNETIC PARTICLES, WITH SATISFACTORY RESULT "According to EN 10480-2 par 4.2.7.2, the material supplied is capable of complying with specified creep rupture strength properties (within the normal scatter band). The manufacturing processes have remained equivalent to those for the steel for which the test results were obtained" "The tubes fulfil the impact requirements specified in the standard EN 10480-2 Par 4.1.6 and EN12952-2 Par 4.2.5.4 and the elongation requirement in longitudinal direction (tensile test) specified in the standard EN10480-2 par.4.1.4 and EN12952-2 Par. 4.2.5.3." "The tubes fulfil the chemistry requirements of EN12952-2 Table 4.2.1, EN12953-2 (par.5, EN10480-2 Table 4.1.1) and VGB-S 109-00-2012-09-DE-EN Par 4.2." TENSILE TEST FREQUENCY IS CALCULATED WITH RESPECT TO MANUFACTURING LENGTHS. That material is fully killed, fine grain SEAMLESS HOT FINISHED PIPES</p>	<p>EN ISO 10693-1 GEPRIEFT, MIT ERFOLGREICHEM ERGEBNIS. DIE RÖHRE SIND 10 MINUTEN BEI 920 °C NORMALISIERT UND ABGERÜHLT IN RUHIGER LUFT DIE RÖHRENDEN (300 mm) WURDEN MITTELS FLUORESZIERENDER MAGNETPULVERPRÜFUNG OHNE BEANFORDERUNG GEPRIEFT DAS GELIEFERTE MATERIAL IST KONFORM GEMÄSS EN 10480-2 ABSCHNITT 4.2.7.2 IST MIT SPEZIFIZIERTEN BRUCHSTANDFESTIGKEITSEIGENSCHAFTEN (INNERHALB DES NORMALEN STREUFANBERTS). DIE HERSTELLUNGSPROZESSE SIND DENEN FÜR DEN STAHL GLEICH GEBLIEBEN. DIE ERSTERGEBNISSE WURDEN ERHALTEN. "Das gelieferte Material entspricht der Kriechbruchfestigkeitscharakter gem. EN 10480-2 Abschnitt 4.1.6 und EN 12952-2 Abschnitt 4.2.5.4 und der Bruchdehnungseigenschaften mit Längsprobenform (Zugversuch) gem. EN 10480-2 Abschnitt 4.1.4 und EN 12952-2 Abschnitt 4.2.5.3" Die Röhre erfüllen die chemischen Anforderungen der EN12952-2 Tabelle 4.2.1, EN12953-2 Par.5-EN10480-2 Tabelle 4.1.1 und VGB-S 109-00-2012-09-DE-EN Par 4.2. ZUGVERSUCH TESTFREQUENZ WIRD IN BEZUG AUF HERSTELLUNGSLENGEN BERECHNET that material is fully killed, fine grain NAHTLOSE WÄRMERÜHLTE STAHLRÖHRE</p>

This certificate is issued by a computerized system and it is valid with electronic signature. On the original certificate the trade-mark green colored "Tenaris" is stamped. In case the owner of the original certificate would release a copy of it, he must attest its conformity to the original one taking upon himself the responsibility for any unlawful or not allowed use. Any alteration and/or falsification will be subjected to the law.

Dieses Zeugnis wird mittels eines Computersystems erstellt und ist mit elektronischer Unterschrift gültig. Das Originalattest ist durch das Tenaris Logo in grün Farbe gekennzeichnet. Beim Erstellen einer Kopie des Originalattests, muss der Eigentümer des Zeugnisses sicherstellen, dass die Kopie dem Original entspricht. Verantwortlich für eine unsachgemässe oder unrichtliche Benutzung, Verändern, Fälschung, kann strafrechtlich verfolgt werden.

INSPECTION CERTIFICATE ABNAHMEPRUEFZEUGNIS (UNI EN 10204 3.1 / ISO 10474 3.1)	Number / Nummer: 01-20-09274	Page / Seite: 8 / 9
Date / Datum: September 26, 2020		

Customer / Kunde: DYLAN STAAL NETHERLANDS B.V.		Customer's Order Item / Kunden Bestell-Nr.: PO-20-DS02531		Customer's Reference / Kunden Referenz-Nr.:		Manufacturer's Works Order N° / Auftrags-Nr.: 1263074/001	
Manufacturing Process / Herstellungsprozess: NORMALIZED NORMALGEGLUEHT		Product Type / Art des Produkts: See note nr.1 Sehen Sie Anmerkung nr.1		Surface / Oberflaeche: BARE INSIDE, EXTERNALLY PROTECTED BY VARNISH INNEN ROH, AUSSEN GEDELT			
Standard or Specification / Norm oder Spezifikation: ACCORDING TO THE NORM EN 10216-2 TC1, PED, AD2000 W4 + TQ 20037055/3.1 GEM. DIN EN 10216-2 TC1, PED, AD2000 W4 + TQ 20037055/3.1				Steel Grade / Werkstoff: STEEL P235GH TC1 STAHL P235GH TC1		Ends / Enden: PLAIN END (SQUARE CUT) GLATTEN ENDEN	
Dimensions / Abmessung: ø 14.000" O.D. x .315" W.T. ø 355.60mm O.D. x 8.00mm W.T.		Schedule / Schedule: .		Length / Laenge: 16.404 ft + 22.966 ft 5000 mm + 7000 mm		Quantity / Menge: 30Pcs/Pz 619'05" ft 30093 lb 188.81 mt 13650 kg	
				Nominal Weight / Theor. Gewicht: 46.08 lb/ft 68.57 Kg/m			

SUPPLEMENTARY INFORMATION / ZUSAEZTLICHE INFORMATIONEN

Supplementary Information Zusätzliche Informationen	
<p>VISUAL AND DIMENSIONAL CONTROL HAS BEEN CARRIED OUT WITH SATISFACTORY RESULT STEEL IS FULLY KILLED AND PRODUCED BY ELECTRIC FURNACE TO A FINE GRAIN PRACTICE THE PRODUCT SUPPLIED IS IN COMPLIANCE WITH THE REQUIREMENTS OF THE ORDER. MANUFACTURED BY TENARIS DALMINE NO WELD REPAIR. MERCURY AND RADIATION FREE AS PER STANDARD, PIPES CAN BE REPAIRED. MANUFACTURER SHOULD DECIDE TO GRIND THE SURFACE OF THE PIPES WHEN, DURING FINAL VISUAL INSPECTION, SOME IMPERFECTIONS ARE DETECTED. THE RESULTED SURFACE AREA, AFTER GRINDING, HAS DIFFERENT COLOURATION COMPARED WITH USUAL ONE AS MANUFACTURED. THE RESIDUAL WALL THICKNESS AFTER GRINDING HAS BEEN CHECKED RESULTING IN TOLERANCE WITH STANDARD.</p> <p>Tenaris IT identification number for MPC: 58cn5Rz</p>	<p>REVISIONS- UND MASSKONTROLLE WURDE OHNE BEANSTANDUNGEN DURCHFUEHRT BERÜHRTER STAHL, AUS FEINKORNIG; IM ELEKTROFEN GEFERTIGT DAS LIEFERTE MATERIAL ENTSPRICHT BESTELLVORSCHRIFTEN. Manufactured by Tenaris Dalmine KEINE SCHWEISSREPARATUREN, QUECKSILBER- UND STRAHLUNGSFREI DIE ROHRLEITUNGEN KÖNNEN STANDEGENÄSSIG REPARIERT WERDEN, DEN BESTEHLICH SIND. ENTSCHEIDEN, OB DIE OBERFLÄCHEN DER ROHRLEITUNGEN GESCHLEFFEN WERDEN SOLLN, WEHN BEI DER ENDLICHEN SICHTPRÜFUNG EINIGE UNREINHEITEN FESTGESTELLT WERDEN. DIE SICH GABEND ERGEBNENDE OBERFLÄCHEN WEISSEN NACH DEM SCHLEFFEN EINE UNTERSCHIEDLICHE FÄRBUNG IM VERGLEICH ZU JENER DES HINGESCHLIFTEN PRODUKTS AUF. DIE RESTWÄNDLSTÄRKE NACH DEM SCHLEFFEN WURDE AUF TOLERANZ IM VERGLEICH ZUM STANDARTEWERT ÜBERPRT. Tenaris IT-Identifikationsnummer für MPC: 58cn5Rz</p>

MARKING / MARKIERUNG

Marking Markierung	
<p>STENCILING _T EN 10216-2 P235GH TC1 355,6 X 8,00 HEAT: _COLATA MT _MT KG _K G NR. _NR QD</p> <p>LEGEND _T = TENARIS Logo _COLATA = Heat Number</p>	<p>LACKIERUNG _T EN 10216-2 P235GH TC1 355,6 X 8,00 HEAT: _COLATA MT _MT KG _K G NR. _NR QD</p> <p>HINWEISTEXT _T = Logo TENARIS _COLATA = Schmelze</p>

This certificate is issued by a computerized system and it is valid with electronic signature. On the original certificate the trade-mark green colored "Tenaris" is stamped. In case the owner of the original certificate would release a copy of it, he must attest its conformity to the original one taking upon himself the responsibility for any unlawful or not allowed use. Any alteration and/or falsification will be subjected to the law.	Dieses Zeugnis wird mittels eines Computersystems erstellt und ist mit elektronischer Unterschrift gültig. Das Originaltest ist durch das Tenaris Logo in grün Farbe erkennlich. Beim Erstellen einer Kopie des Originaltestes, muss der Eigentümer des Zeugnisses sicherstellen, dass die Kopie dem Original entspricht. Verantwortlich fuer eine ungesetzliche oder unrechliche Benutzung uebernehmen. Jegliche Aenderung oder Falschung kann strafrechtlich verfolgt werden.
---	---



INSPECTION CERTIFICATE ABNAHMEPRUEFZEUGNIS (UNI EN 10204 3.1 / ISO 10474 3.1)	Number / Nummer: 01-20-09274	Page / Seite: 9 / 9
Date / Datum: September 26, 2020		

Customer / Kunde: DYLAN STAAL NETHERLANDS B.V.		Customer's Order Item / Kunden Bestell-Nr.: PO-20-DS02531		Customer's Reference / Kunden Referenz-Nr.:		Manufacturer's Works Order N° / Auftrags-Nr.: 1263074/001	
Manufacturing Process / Herstellungsprozess: NORMALIZED NORMALGEGLUEHT		Product Type / Art des Produkts: See note nr.1 Sehen Sie Anmerkung nr.1		Surface / Oberfläche: BARE INSIDE, EXTERNALLY PROTECTED BY VARNISH INNEN ROH, AUSSEN GEOELT			
Standard or Specification / Norm oder Spezifikation: ACCORDING TO THE NORM EN 10216-2 TC1, PED, AD2000 W4 + TQ 20037055/3.1 GEM. DIN EN 10216-2 TC1, PED, AD2000 W4 + TQ 20037055/3.1		Steel Grade / Werkstoff: STEEL P235GH TC1 STAHL P235GH TC1		Ends / Enden: PLAIN END (SQUARE CUT) GLATTEN ENDEN			
Dimensions / Abmessung: ø 14.000" O.D. x .315" W.T. ø 355.60mm O.D. x 8.00mm W.T.		Schedule / Schedule: Length / Laenge: 16.404 ft + 22.966 ft 5000 mm + 7000 mm		Quantity / Menge: 30 Pcs/Pz 619'05" ft 30093 lb 188.81 mt 13650 kg		Nominal Weight / Theor. Gewicht: 46.08 lb/ft 68.57 Kg/m	

MARKING / MARKIERUNG

Marking Markierung	
_MT = Pipe/Tube Length in meters _NR = Pipe/Tube identifier	_MT = Rohrlänge in Metern _NR = ID der Röhre

This is to certify that the product described here has been manufactured, sampled, tested, and inspected in accordance with purchaser order requirements. This certificate is not a declaration of origin nor may it be used as a declaration of origin. Hiermit wird bestätigt, dass das im Attest beschriebene Material gemäss der Anforderungen der Bestellung hergestellt, geprüft und abgenommen wurde. Dieses Attest ist keine Ursprungserklärung und kann nicht als solche verwendet werden.

	CUSTOMER THIRD PARTY	TENARIS QUALITY DEPARTMENT SIGNATURE	
	INSPECTION COMPANY ABNAHMEGESELLSCHAFT		
	QUALITY CERTIFICATION DEPT. QUALITAETS- UND ZEUGNISABTEILUNG SIGOLI Gianluca	CHIEF OF QUALITY CERTIFICATION DEPT. LEITER DER QUALITAETS- UND ZEUGNISABTEILUNG FERRARI Donato	

This certificate is issued by a computerized system and it is valid with electronic signature. On the original certificate the trade-mark green colored "Tenaris" is stamped. In case the owner of the original certificate would release a copy of it, he must attest its conformity to the original one taking upon himself the responsibility for any unlawful or not allowed use. Any alteration and/or falsification will be subjected to the law.

Dieses Zeugnis wird mittels eines Computersystems erstellt und ist mit elektronischer Unterschrift gültig. Das Originalattest ist durch das Tenaris Logo in grüner Farbe erkennlich. Beim Erstellen einer Kopie des Originalattests, muss der Eigentümer des Zeugnisses sicherstellen, dass die Kopie dem Original entspricht. Jegliche Änderung oder Fälschung kann strafrechtlich verfolgt werden.

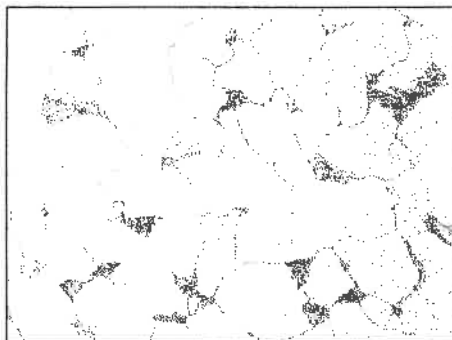

Mill order : 1263074/001

Heat/Lot : 902651/1

Test Code : R1472/00

Etching : Nital 3%

Magnification : X 500
Direction : Longitudinal

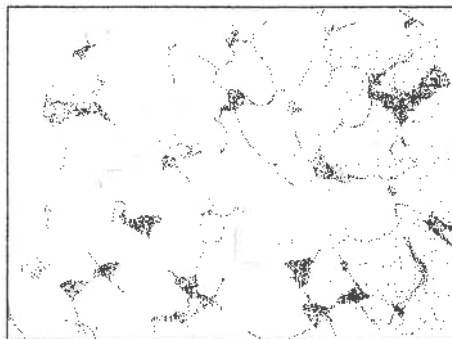

Mill order : 1263074/001

Heat/Lot : 909201/1

Test Code : R1470/C

Etching : Nital 3%

Magnification : X 500

Direction : Longitudinal

EN 10 204-3.1 (2004)/PED 2014/68/EU

A 18758 -001

20.05.2020

Tilaja Purchaser
TIBNOR OY
NIINISTÖNKATU 7
05800 HYVINKÄÄ FINLAND

Tilaus nro Order No.
4501203356

Tilausvahvistus Order Confirmation
18758

Vastaanottaja Consignee
TIBNOR OY
TUOTTAJANTIE 49
60100 SEINÄJOKI FINLAND
Asiakkaan merkki Shipping mark

Päivämäärä Date
22.05.2020

Valmistajan merkki
Mark of the Manufacturer



Todistus Certificate
3NVPED

Laivaus Shipping

Laatumerkintä Quality Marking
P265GH SA516GR60MT A516GR60MT

Tarkastajan leima
Stamp of Inspector

Mxx

Vastaanottajan leima
Stamp of Surveyor

Toimitustyyppi Delivery type
PART DELIVERY

Sulatus nro levy nro Cast No. Plate No.
XXXXX XXX XX XXX

Muut leimaukset
Other Stamps

Tuote Product
HEAVY PLATES
Laji Grade
P265GH/A516/SA516 GR 60 MT EN 10028-2:17/ASTM/ASME 516
Laatuselvitys Quality Specifications
PRESSURE VESSEL STEEL EN10028-2:17/ASTM A20-19/ASME SA20-19

Toleranssit Tolerances
EN 10029:2010 CLASS B

Tekniset vaatimukset ja/tai viralliset määräykset Technical terms of Delivery and/or Official Regulations

SI- AND AL-KILLING

Positio Item	Mitat mm Dimensions mm	Merkki Marke	Kpl Pcs	Paino kg Weight kg	Sulatus levy nro Cast plate No	SP nro SP No	UT	MT
-----------------	---------------------------	-----------------	------------	-----------------------	-----------------------------------	-----------------	----	----

NORMALIZED STEEL PLATES

ASTM A516-17/ASME SA516-19

SURFACE CONDITION EN 10 163-2:2005 CLASS B3

050	30.00 X 2450	X	8000	4501203356	B001.A07160	STD	2	9760	54313	051	051
050	30.00 X 2450	X	8000				2	9760	54313	052	052

*** 4 19520

LE16120

Raah Steel Works

Testaus ja tarkastus Testing and Inspection

Minna Valkama

MINNA VALKAMA

Valtuutettu tarkastaja Authorized inspection representative

Yhtiön nimi Company Name: SSAB Europe Oy
Kotipaikka Registered Office: HÄMEENLINNA

Osoite Address: PL 93, P.O Box 93
FIN-92101 RAAHE, FINLAND

Puhelin Telephone: 020 5911
+358 20 5911

Y-tunnus Business ID: 2389445-7

Täten todistamme, että toimitus on tilausvahvistuksen mukainen.
We hereby certify that the material described above has been tested and complies with the terms of the order confirmation.

Certified to comply with the Pressure Equipment Directive 2014/68/EU annex 1, section 4.3. by DNV GL (138046-2013-CE-FIN-DNV GL) according to the quality system standard EN ISO 9001:2015. Certificate No. 91659CC31-2011-AQ-FIN-FINAS.

Tilaja Purchaser
TIBNOR OY
NIINISTÖNKATU 7
05800 HYVINKÄÄ FINLAND
Tilaus nro Order No.
4501203356

Tilausvahvistus Order Confirmation
18758

Vastaanottaja Consignee
TIBNOR OY
TUOTTAJANTIE 49
60100 SEINÄJOKI FINLAND
Asiakkaan merkki Shipping mark

Päivämäärä Date
22.05.2020 MLK

Valmistajan merkki
Mark of the Manufacturer



Laji Grade
P265GH/A516/SA516 GR 60 MT

Lisävaatimukset Additional requirements
SI- AND AL-KILLING

Jatkuvavalettua happiterästä
Oxygen steel, continuous casting

Laatuselvitys Quality Specifications

PRESSURE VESSEL STEEL EN10028-2:17/ASTM A20-19/ASME SA20-19

Fully killed, Fine grain practiced

N 900C,T=1.1(MIN)X THICKN(MM)

Pos. Item	Sulatus, k.erä nro Cast. test No	T-tila Cond	Vetokoe Tensile test													Taivutuskoe Bend test		Huom Nb	Päästö Tempering °C							
			K2	°C	RP02 MPa	RT05 MPa	REL MPa	REH MPa	RM MPa			A %			REH / RM	RM * A5	RAZ %			Keskiarvo Average	K5	D = X t				
050	54313	051	N	J1		297						443		30												
				5C	+300	183																				
050	54313	052	N	J1		290						441		29												

K2: J1=BOTTOM,TRANSV. 5C=RPO.2

N =NORMALIZED

Pos. Item	Sulatus, k.erä nro Cast. test No	Iskukoe Impact test							FA %						LE (mm)						Erikoiskokeet Special tests						Huom Nb	Päästö Tempering °C
		K3	°C	1	2	3	Keskiarvo Average	W (mm)	1	2	3	Keskiarvo Average	1	2	3	Keskiarvo Average	K4	°C	1	2	Keskiarvo Average							
050	54313	051	152	-020	71	75	76	74																				
050	54313	052	152	-020	60	67	73	67																				

K3: 152=CH-V/ISO-V(J),10X10,BOTTOM,TRANSV,KV600

Raah Steel Works

Täten todistamme, että toimitus on tilausvahvistuksen mukainen.
We hereby certify that the material described above has been tested and complies with the terms of the order confirmation.

Testaus ja tarkastus Testing and Inspection

MINNA VALKAMA

Valtuutettu tarkastaja Authorized inspection representative

Yhtiön nimi Company Name: SSAB Europe Oy
Kotipaikka Registered Office: HÄMEENLINNA

Osioite Address: PL 93, P.O Box 93
FIN-92101 RAAHE, FINLAND

Puhelin Telephone: 020 5911
+358 20 5911

Y-tunnus Business ID: 2389445-7

Sulatus nro Cast No Schmelzen Nr. No de coulén № Плавки	Koe nro Test No Prüf Nr. Essai No № Пробы	Positio Item Pos. Poste Поз.	Cekv Ceq Caq Cég Cekv	Analyysi % Chemical composition % Chemisch Zusammensetzung % Composition Chimique % Анализ плавки % (*=ppm)																Päivämäärä Date Datum Date Дата			
				C	SI	MN	P	S	AL	NB	V	TI	CU	CR	NI	MO	N	B	22.05.2020	MLK			
54313		050	.33	.150	.27	1.01	.017	.008	.041	.001	.013	.001	.006	0.03	0.03	.001	.003	.0002					

CEQ=C+Mn/6+(Cr+Mo+V)/5+(Ni+Cu)/15

Raahe Steel Works

Testaus ja tarkastus Testing and Inspection Испытание и контроль качества
Prüfung und Kontrolle Essais et Contrôle

Steel manufactured and supplied by Raahe Steel Works is free from radiation.
Производимая на металлургическом комбинате «Raahe Steel Works» и поставляемая
заказчику сталь не излучают радиации.

MINNA VALKAMA

Valtuutettu tarkastaja Authorized inspection representative Уполномоченный инспектор
Sachverständiger Inspector autorisé

Yhtiön nimi Company Name: SSAB Europe Oy Osoite Address: PL 93, P.O Box 93
Kotipaikka Registered Office: HÄMEENLINNA FIN-92101 RAAHE, FINLAND

Puhelin Telephone: 020 5911
+358 20 5911

Y-tunnus Business ID: 2389445-7



SE5998



INSPECTION CERTIFICATE EN 10204 - 3.1

Inspection Certificate / Certificate de Reseption

No. WZ-00038883

Lindemann GmbH & Co. KG · Albert-Schweitzer-Str. 179 · 32257 Bünde · Deutschland

Onninen OY
Mittalinja 1
1260 Vantaa
Finland

Datum/Date: 30. October 2020
Seite/Page/Page: 1 of 1
Bestell-Nr./Order-No./No. commandé: 4500790507
Auftrags-Nr./Order-No./No. De commandé: AB-20-00812
LS-Nr./Delivery Note/Bon de Livraison: LI-20-002918

Pos.-Nr. Item Poste	Stückzahl Quantity Nombre		Schmelze-Kenn-Nr. Heat-id-No. No. de Coulée	Schmelze-Nr. Heat-No. No. de coulée
260	150	Seamless Elbows EN10253-2 Type A P235GH TC1 - EN10216-2 60,3 x 4,5 3D 90° bevelled ends	E3650	-298345
Technical conditions: EN 10253-2 Option 9/14/20 09-2008, AD2000-W4 02-2013, HP8/3 02-2010, HP100R 09-2016, VdTÜV Mbl. 1252 11-2012, PED 2014/68/EU				

Ergebnis der Prüfungen/Test results/Result des essais

Probe-Nr. Specimen- No. Eprovette No.	Probenlage Test position Position de l'éprouvette	Abmessung der Probe Dimensions Dimensions	Tensile Test					Impact Test			Hardness Test
			Prüftemperat. Test temperat. Temp. d'essai	Streckgrenze Yield strength Limite elastiq	Zugfestigkeit Tensile strength Résistance à la traction	Dehnung Elongation Allongement	Einschnürung Reduction Striction	Kerbschlagarbeit Impact Value Résilience		Härte HB 187,5/2,5 Hardness Dureté	
			Degree C°	Mpa	Mpa	2"/5d%	%	Joule	L=Long Q=Trans	Degree C°	
	L=Longitudinal Q=Transverse T=Tangential	Anforderungen: Requirements Conditions	20	>=235	360-500	L>=25 / Q>=23	-	ISO-V	L>=40J / Q>=27J	0°C	107-145
P0015117											122-134

Wärmebehandlungszustand/Heattreatment/Traitement thermique: normalisierend umgeformt, hot formed at controlled temp.

Verformungstemperatur/Forming temperature: 850-950°C

Besichtigung und Abmessung/Visual inspection and dimensionel check/Contrôle visual et dimensionel: in order

Verwechslungsprüfung/Spectrum analysis/Analyse spectrale: ---

Zerstörungsfreie Prüfung/Non-destructive test/Contrôle non destructive: ---

Markierung/Marking/Marquage: Logo, Werkstoff, Schmelze-Nr., Werksachverständigenzeichen, Produktnorm,

Werkstoffgüternachweis des Einsatzrohres/Certificate of base material/Certificate des materiaux utilisés

Hersteller/Manufacturer/Fournisseur: Maxhütte

DIN17175/EN10216-2

Rohrzeugnis-Nr./Tube WC/No./Tube C d/un/no.: VK1800160040P 235 GH TC1 - 3.1

Schmelze-Nr./Heat-No./No. de coulée: 298345

% C	% Si	% Mn	% P	% S	% Cr	% Mo	% Ni	% Al	% N	% Cu	% Nb	% Ti	% V	CEV
0,080	0,230	0,490	0,006	0,005	0,160	0,040	0,120	0,026	0,0083	0,100	0,001	0,001	0,00	0,220

Zertifiziert nach Druckgeräterichtlinie 2014/68/EU
Certified acc. to PED 2014/68/EU
Überprüft als Hersteller nach AD2000-W0/TRD 100
Producer acc. AD2000-W0/TRD 100

Die gestellten Anforderungen sind erfüllt
The requirements are fulfilled
Les conditions imposées sont satisfaites

**LINDEMANN GmbH & Co.KG
ORION EISENVERARBEITUNG**

Der Abnahmebeauftragter / WL

Dirk Krüger



Project:

Client: SSAB Europe Oy, Raahe Steel Works,
Raahe, Finland

Office: Helsinki

Clients Order Number: A20123

Date: 12 October 2020

Order Status: InComplete

Inspection Dates

First: 12 October 2020

Final: 12 October 2020

This certificate is issued to SSAB Europe Oy, Raahe Steel Works to certify that the material described herein has been accepted at their works.

The material inspected was stated intended for BE GROUP OY AB, PL 54,
15101 LAHTI FINLAND, against their order number P084213.

Description: Four (4) HOT ROLLED STEEL PLATES
For details see the attached manufacturer's inspection certificate no. A20123-001A.

Specification: P265GH EN 10028-2:2017 TOLERANCES ACC. TO EN 10029:2010 CLASS C

Scope of inspection carried out:

This certificate is based on Lloyd's Register's Materials Quality Scheme MQS 007
which is audited three times a year.

Manufacturer's Inspection Certificate and Test Report reviewed and endorsed (attached).

Material inspected by Manufacturer.

Identification of plates: Manufacturer's Brand, Quality, Cast No. and LR

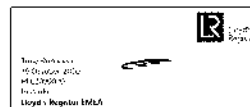

Timo Rinkinen
Surveyor to Lloyd's Register EMEA

A subsidiary of Lloyd's Register Group Limited

Lloyd's Register Group Limited, its affiliates and subsidiaries and their respective officers, employees or agents are, individually and collectively, referred to in this clause as 'Lloyd's Register'. Lloyd's Register assumes no responsibility and shall not be liable to any person for any loss, damage or expense caused by reliance on the information or advice in this document or howsoever provided, unless that person has signed a contract with the relevant Lloyd's Register entity for the provision of this information or advice and in that case any responsibility or liability is exclusively on the terms and conditions set out in that contract.

Tilaja Purchaser
BE GROUP OY AB
PL 54
15101 LAHTI FINLAND

Vastaanottaja Consignee
BE GROUP OY AB
PAAKARLANTIE 3
20240 TURKU FINLAND

Päivämäärä Date
12.10.2020 HEL 2090020/9

Tilaus nro Order No. P084213
Tilausvahvistus Order Confirmation 20123

Asiakkaan merkki Shipping mark

Valmistajan merkki Mark of the Manufacturer



Todistus Certificate
4C0LR

Laivaus Shipping

Laatumerkintä Quality Marking
P265GH

Tarkastajan leima Stamp of Inspector

Mxx

LR

Toimitustyyppi Delivery type
PART DELIVERY

Sulatus nro levy nro Cast No. Plate No.
XXXXX XXX XX XXX

Vastaanottajan leima Stamp of Surveyor

Muut leimaukset Other Stamps

Tuote Product
HEAVY PLATES
Laji Grade
P265GH EN 10028-2:2017
Laatuselvitys Quality Specifications
PRESSURE VESSEL STEEL

Toleranssit Tolerances
EN 10029:2010 CLASS C

Tekniset vaatimukset ja/tai viralliset määräykset Technical terms of Delivery and/or Official Regulations

Positio Item	Mitat mm Dimensions mm	Merkki Marke	Kpl Pcs	Paino kg Weight kg	Sulatus levy nro Cast plate No	SP nro SP No	UT	MT
--------------	------------------------	--------------	---------	--------------------	--------------------------------	--------------	----	----

NORMALIZED STEEL PLATES

FLATNESS MAX 6MM/M. .SURFACE CONDITION EN 10 163-2:2005 CLASS B3

001	10.00 X 2450	X	8000	2100173300	2	3136	59077	032	032
001	10.00 X 2450	X	8000		2	3136	59077	033	033

*** 4 6272

Raabe Steel Works

Testaus ja tarkastus Testing and Inspection

Minna Valkama

MINNA VALKAMA

Valtuutettu tarkastaja Authorized inspection representative

This is to certify that the material described above has been manufactured and tested with satisfactory results in accordance with the above mentioned standard and Quality.

This Mill Sheet and Test Certificate is issued by the manufacturer in accordance with the arrangements authorized by Lloyd's Register EMEA in a Manufacturing Survey Agreement based on LR Materials Quality Scheme MQS 007. I certify that these arrangements are being kept under review by regular and systematic auditing of the approved manufacturing and Quality Control Procedures.

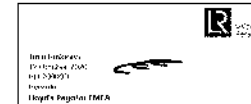

Yhtiön nimi Company Name: SSAB Europe Oy
Kotipaikka Registered Office: HÄMEENLINNA

Osoite Address: PL 93, P.O Box 93
FIN-92101 RAAHE, FINLAND

Puhelin Telephone: 020 5911
+358 20 5911

Y-lunnus Business ID: 2389445-7

Sulatus nro Cast No Schmelzen Nr No de coulée № Плавки	Koe nro Test No Prüf Nr. Essai No № Пробы	Positio Item Pos. Poste Поз.	Cekv Ceq Câq Cég Секв	Analyysi % Chemical composition % Chemisch Zusammensetzung % Composition Chimique % Анализ плавки % (*=ppm)															Päivämäärä Date Datum Date Дата	
				C	SI	MN	P	S	AL	NB	V	TI	CU	CR	NI	MO	N	B		MLK
59077		001	.33	.128	.30	1.14	.007	.004	.037	.000	.006	.004	.013	0.04	0.04	.003	.004	.0003	12.10.2020	

CEQ=C+Mn/6+(Cr+Mo+V)/5+(Ni+Cu)/15

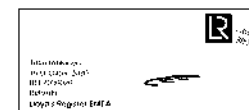

Raabe Steel Works

Testaus ja tarkastus Testing and Inspection Испытание и контроль качества
Prüfung und Kontrolle Essais et Contrôle

Steel manufactured and supplied by Raabe Steel Works is free from radiation.
Производимая на металлургическом комбинате «Raabe Steel Works» и поставляемая заказчику сталь не излучает радиации.

Minna Valkama

MINNA VALKAMA

Valtuutettu tarkastaja Authorized inspection representative Уполномоченный инспектор
Sachverständiger Inspecteur autorisé

Yhtiön nimi Company Name: SSAB Europe Oy Osoite Address: PL 93, P.O Box 93
Kotipaikka Registered Office: HÄMEENLINNA FIN-92101 RAAHE, FINLAND

Puhelin Telephone: 020 5911
+358 20 5911

Y-tunnus Business ID: 2389445-7



Project:

Client: SSAB Europe Oy, Raahе Steel Works,
Raahе, Finland

Office: Helsinki

Clients Order Number: A20123

Date: 12 October 2020

Order Status: InComplete

Inspection Dates

First: 12 October 2020

Final: 12 October 2020

This certificate is issued to SSAB Europe Oy, Raahе Steel Works to certify that the material described herein has been accepted at their works.

The material inspected was stated intended for BE GROUP OY AB, PL 54,
15101 LAHTI FINLAND, against their order number P084213.

Description: Four (4) HOT ROLLED STEEL PLATES
For details see the attached manufacturer's inspection certificate no. A20123-001B.

Specification: SA516 GR 60 MTLTV ASME SA-516-2019 TOLERANCES ACC. TO EN 10029:2010 CLASS C

Scope of inspection carried out:

This certificate is based on Lloyd's Register's Materials Quality Scheme MQS 007
which is audited three times a year.

Manufacturer's Inspection Certificate and Test Report reviewed and endorsed (attached).

Material inspected by Manufacturer.

Identification of plates: Manufacturer's Brand, Quality, Cast No. and LR

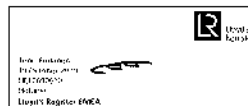

Timo Rinkinen
Surveyor to Lloyd's Register EMEA

A subsidiary of Lloyd's Register Group Limited

Lloyd's Register Group Limited, its affiliates and subsidiaries and their respective officers, employees or agents are, individually and collectively, referred to in this clause as 'Lloyd's Register'. Lloyd's Register assumes no responsibility and shall not be liable to any person for any loss, damage or expense caused by reliance on the information or advice in this document or howsoever provided, unless that person has signed a contract with the relevant Lloyd's Register entity for the provision of this information or advice and in that case any responsibility or liability is exclusively on the terms and conditions set out in that contract.

EN 10 204-3.2/LR (2004)

Tilaja Purchaser
BE GROUP OY AB
PL 54
15101 LAHTI FINLAND

Vastaanottaja Consignee
BE GROUP OY AB
PAAKARLANTIE 3
20240 TURKU FINLAND

Päivämäärä Date
12.10.2020 HEL 2090020/9 A

Tilaus nro Order No.
P084213

Tilausvahvistus Order Confirmation
20123

Asiakkaan merkki Shipping mark

Valmistajan merkki
Mark of the Manufacturer



Todistus Certificate
4C0LR

Laivaus Shipping

Laatumerkintä Quality Marking
SA516GR60MTLV

Tarkastajan leima
Stamp of Inspector

Mxx

LR

Toimitustyyppi Delivery type
PART DELIVERY

Sulatus nro levy nro Cast No. Plate No.
XXXXX XXX XX XXX

Vastaanottajan leima
Stamp of Surveyor

Muut leimaukset
Other Stamps

Tuote Product
HEAVY PLATES
Laji Grade
SA516 GR 60 MTLTV ASME SA-516-2019
Laatuselvitys Quality Specifications
PRESS.VESSEL STEEL ASME CODE SEC II ED 2019 SA20

Toleranssit Tolerances
EN 10029:2010 CLASS C

Tekniset vaatimukset ja/tai viralliset määräykset Technical terms of Delivery and/or Official Regulations

Positio Item	Mitat mm Dimensions mm	Merkki Marke	Kpl Pcs	Paino kg Weight kg	Sulatus levy nro Cast plate No	SP nro SP No	UT UT	MT MT
-----------------	---------------------------	-----------------	------------	-----------------------	-----------------------------------	-----------------	----------	----------

NORMALIZED STEEL PLATES

FLATNESS MAX 6MM/M. .SURFACE CONDITION EN 10 163-2:2005 CLASS B3

001	10.00 X 2450	X	8000	2100173300				
			2	3136	59077	032	032	
001	10.00 X 2450	X	8000					
			2	3136	59077	033	033	

*** 4 6272

Raabe Steel Works

Testaus ja tarkastus Testing and Inspection

Minna Valkama

MINNA VALKAMA

Valtuutettu tarkastaja Authorized inspection representative

This is to certify that the material described above has been manufactured and tested with satisfactory results in accordance with the above mentioned standard and Quality.

This Mill Sheet and Test Certificate is issued by the manufacturer in accordance with the arrangements authorized by Lloyd's Register EMEA in a Manufacturing Survey Agreement based on LR Materials Quality Scheme MQS 007. I certify that these arrangements are being kept under review by regular and systematic auditing of the approved manufacturing and Quality Control Procedures.

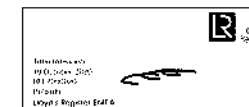

Yhtiön nimi Company Name: SSAB Europe Oy
Kotipaikka Registered Office: HÄMEENLINNA

Osoite Address: PL 93, P.O Box 93
FIN-92101 RAAHE, FINLAND

Puhelin Telephone: 020 5911
+358 20 5911

Y-lunnus Business ID: 2389445-7

Sulatus nro Cast No Schmelzen Nr No de coulée № Плавки	Koe nro Test No Prüf Nr. Essai No № Пробы	Positio Item Pos. Poste Поз.	Cekv Ceq Câq Cég Секв	Analyysi % Chemical composition % Chemisch Zusammensetzung % Composition Chimique % Анализ плавки % (*=ppm)																Päivämäärä Date Datum Date Дата	
				C	SI	MN	P	S	AL	NB	V	TI	CU	CR	NI	MO	N	B	12.10.2020	MLK	
59077		001	.33	.128	.30	1.14	.007	.004	.037	.000	.006	.004	.013	0.04	0.04	.003	.004	.0003			

CEQ=C+Mn/6+(Cr+Mo+V)/5+(Ni+Cu)/15

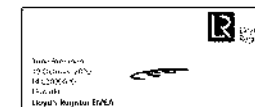

Raabe Steel Works

Testaus ja tarkastus Testing and Inspection Испытание и контроль качества
Prüfung und Kontrolle Essais et Contrôle

Steel manufactured and supplied by Raabe Steel Works is free from radiation.
Производимая на металлургическом комбинате «Raabe Steel Works» и поставляемая
заказчику сталь не излучает радиации.

Minna Valkama

MINNA VALKAMA

Valtuutettu tarkastaja Authorized inspection representative Уполномоченный инспектор
Sachverständiger Inspecteur autorisé

Yhtiön nimi Company Name: SSAB Europe Oy Osoite Address: PL 93, P.O Box 93
Kotipaikka Registered Office: HÄMEENLINNA FIN-92101 RAAHE, FINLAND

Puhelin Telephone: 020 5911
+358 20 5911

Y-tunnus Business ID: 2389445-7

Tilaja Purchaser
BE GROUP OY AB
PL 54
15101 LAHTI FINLAND

Vastaanottaja Consignee
BE GROUP OY AB
PAAKARLANTIE 3
20240 TURKU FINLAND

Päivämäärä Date
12.10.2020

Tilaus nro Order No.
P084213

Tilausvahvistus Order Confirmation
20123

Asiakkaan merkki Shipping mark

Valmistajan merkki
Mark of the Manufacturer



Todistus Certificate
4A1TUV

Laivaus Shipping

Laatumerkintä Quality Marking
P265GH

Tarkastajan leima
Stamp of Inspector

Mxx

Toimitustyyppi Delivery type
PART DELIVERY

Sulatus nro levy nro Cast No. Plate No.
XXXXX XXX XX XXX

Vastaanottajan leima
Stamp of Surveyor

Muut leimaukset
Other Stamps

Tuote Product
HEAVY PLATES

Toleranssit Tolerances
EN 10029:2010 CLASS C

Tekniset vaatimukset ja/tai viralliset määräykset Technical terms of Delivery and/or Official Regulations

Laji Grade
P265GH EN 10028-2:2017
Laatuselvitys Quality Specifications
PRESSURE VESSEL STEEL

PED 2014/68/EU/AD 2000-W1

Positio Item	Mitat mm Dimensions mm	Merkki Marke	Kpl Pcs	Paino kg Weight kg	Sulatus levy nro Cast plate No	SP nro SP No	UT	MT
-----------------	---------------------------	-----------------	------------	-----------------------	-----------------------------------	-----------------	----	----

NORMALIZED STEEL PLATES

FLATNESS MAX 6MM/M. .SURFACE CONDITION EN 10 163-2:2005 CLASS B3

001	10.00 X 2450	X	8000	2100173300	2	3136	59077	032	032
001	10.00 X 2450	X	8000		2	3136	59077	033	033

*** 4 6272

BESICHTIGUNG UND MASSKONTROLLE OHNE FEHLBEFUND

Raabe Steel Works

Testaus ja tarkastus Testing and Inspection

Täten todistamme, että toimitus on tilausvahvistuksen mukainen.
We hereby certify that the material described above has been tested and complies with the terms of the order confirmation.

Approved acc. to AD 2000-Merkblatt W 0 and certified acc. to PED (2014/68/EU) by
Notified Body for Pressure Equipment of TÜV NORD Systems GmbH & Co. KG
(Reg. No.: 0045).

Minna Valkama

MINNA VALKAMA

Valtuutettu tarkastaja Authorized inspection representative

Yhtiön nimi Company Name: SSAB Europe Oy
Kotipaikka Registered Office: HÄMEENLINNA

Osoite Address: PL 93, P.O Box 93
FIN-92101 RAAHE, FINLAND

Puhelin Telephone: 020 5911
+358 20 5911

Y-lunnus Business ID: 2389445-7

Tilaja Purchaser
BE GROUP OY AB
PL 54
15101 LAHTI FINLAND
Tilaus nro Order No.
P084213

Tilausvahvistus Order Confirmation
20123

Vastaanottaja Consignee
BE GROUP OY AB
PAAKARLANTIE 3
20240 TURKU FINLAND
Asiakkaan merkki Shipping mark

Päivämäärä Date
12.10.2020
MLK

Valmistajan merkki
Mark of the Manufacturer



Laji Grade
P265GH

Lisävaatimukset Additional requirements

Jatkuvavalettua happiterästä
Oxygen steel, continuous casting

Laatuselitys Quality Specifications
PRESSURE VESSEL STEEL

PED 2014/68/EU/AD 2000-W1

Fully killed, Fine grain practiced

Pos. Item	Sulatus k. erä nro Cast. test No	T-tila Cond	Vetokoe Tensile test													Taivutuskoee Bend test		Huom Nb	Päästö Tempering °C						
			K2	°C	RP02 MPa	RT05 MPa	REL MPa	REH MPa	1	RM MPa 2	3	50	A % 80	200	RE / RM	RM * A5	1			RAZ % 2	3	Keskiarvo Average	K5	D = X t	
001	59077 032	N F1			314					323	457			35											
		1C +300			192																				
001	59077 033	N F1			311					320	456			34											

K2: F1=TOP,TRANSV, 1C=RP0.2

N=NORMALIZED

Pos. Item	Sulatus k. erä nro Cast. test No	Iskukoe Impact test				FA %			LE (mm)			Eriskokeet Special tests				Huom Nb	Päästö Tempering °C			
		K3	°C	1	2	3	Keskiarvo Average	W (mm)	1	2	3	Keskiarvo Average	K4	°C	1			2	Keskiarvo Average	
001	59077 032	116	-020	101	105	103	103													
001	59077 033	116	-020	94	98	101	98													

K3: 116=CH-V/ISO-V(J),7.5X10, TOP,TRANSV, KV600

Raabe Steel Works

Täten todistamme, että toimitus on tilausvahvistuksen mukainen.
We hereby certify that the material described above has been tested and complies with the terms of the order confirmation.

Testaus ja tarkastus Testing and Inspection

Minna Valkama

MINNA VALKAMA

Valtuutettu tarkastaja Authorized inspection representative

Yhtiön nimi Company Name: SSAB Europe Oy
Kotipaikka Registered Office: HÄMEENLINNA

Osioite Address: PL 93, P.O Box 93
FIN-92101 RAAHE, FINLAND

Puhelin Telephone: 020 5911
+358 20 5911

Y-tunnus Business ID: 2389445-7

Sulatus nro Cast No Schmelzen Nr No de coulée № Плавки	Koe nro Test No Prüf Nr. Essai No № Пробы	Positio Item Pos. Poste Поз.	Cekv Ceq Câq Cég Секв	Analyysi % Chemical composition % Chemisch Zusammensetzung % Composition Chimique % Анализ плавки % (*=ppm)															Päivämäärä Date Datum Date Дата	
				C	SI	MN	P	S	AL	NB	V	TI	CU	CR	NI	MO	N	B	12.10.2020	MLK
59077		001	.33	.128	.30	1.14	.007	.004	.037	.000	.006	.004	.013	0.04	0.04	.003	.004	.0003		

CEQ=C+Mn/6+(Cr+Mo+V)/5+(Ni+Cu)/15

Raahe Steel Works

Testaus ja tarkastus Testing and Inspection Испытание и контроль качества
Prüfung und Kontrolle Essais et Contrôle

Steel manufactured and supplied by Raahe Steel Works is free from radiation.
Производимая на металлургическом комбинате «Raahe Steel Works» и поставляемая
заказчику сталь не излучает радиации.



MINNA VALKAMA

Valtuutettu tarkastaja Authorized inspection representative Уполномоченный инспектор
Sachverständiger Inspecteur autorisé

Yhtiön nimi Company Name: SSAB Europe Oy Osoite Address: PL 93, P.O Box 93
Kotipaikka Registered Office: HÄMEENLINNA FIN-92101 RAAHE, FINLAND

Puhelin Telephone: 020 5911
+358 20 5911

Y-tunnus Business ID: 2389445-7



Project:

Client: SSAB Europe Oy, Raahе Steel Works,
Raahе, Finland

Office: Helsinki

Clients Order Number: A19617

Date: 25 September 2020

Order Status: Complete

Inspection Dates

First: 25 September 2020

Final: 25 September 2020

This certificate is issued to SSAB Europe Oy, Raahе Steel Works to certify that the material described herein has been accepted at their works.

The material inspected was stated intended for BE GROUP OY AB, PL 54,
15101 LAHTI FINLAND, against their order number P083419.

Description: Seven (7) HOT ROLLED STEEL PLATES
For details see the attached manufacturer's inspection certificate no. A19617-002A.

Specification: P265GH EN 10028-2:2017 TOLERANCES ACC. TO EN 10029:2010 CLASS C

Scope of inspection carried out:

This certificate is based on Lloyd's Register's Materials Quality Scheme MQS 007
which is audited three times a year.

Manufacturer's Inspection Certificate and Test Report reviewed and endorsed (attached).

Material inspected by Manufacturer.

Identification of plates: Manufacturer's Brand, Quality, Cast No. and LR

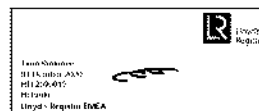

Timo Rinkinen
Surveyor to Lloyd's Register EMEA

A subsidiary of Lloyd's Register Group Limited

Lloyd's Register Group Limited, its affiliates and subsidiaries and their respective officers, employees or agents are, individually and collectively, referred to in this clause as 'Lloyd's Register'. Lloyd's Register assumes no responsibility and shall not be liable to any person for any loss, damage or expense caused by reliance on the information or advice in this document or howsoever provided, unless that person has signed a contract with the relevant Lloyd's Register entity for the provision of this information or advice and in that case any responsibility or liability is exclusively on the terms and conditions set out in that contract.

EN 10 204-3.2/LR (2004)

 Tilaja Purchaser
 BE GROUP OY AB
 PL 54
 15101 LAHTI FINLAND

 Vastaanottaja Consignee
 BE GROUP OY AB
 PAAKARLANTIE 3
 20240 TURKU FINLAND
 Asiakkaan merkki Shipping mark

 Päivämäärä Date
 25.09.2020 HEL 2090019/11

 Tilaus nro Order No.
 P083419

 Tilausvahvistus Order Confirmation
 19617

 Valmistajan merkki
 Mark of the Manufacturer

 Todistus Certificate
 4C0LR

Laivaus Shipping

 Laatumerkintä Quality Marking
 P265GH

 Tarkastajan leima
 Stamp of Inspector

Mxx

LR

 Toimitustyyppi Delivery type
 REST DELIVERY

 Sulatus nro levy nro Cast No. Plate No.
 XXXXX XXX XX XXX

 Vastaanottajan leima
 Stamp of Surveyor

 Muut leimaukset
 Other Stamps

 Tuote Product
 HEAVY PLATES
 Laji Grade
 P265GH EN 10028-2:2017
 Laatuselvitys Quality Specifications
 PRESSURE VESSEL STEEL

 Toleranssit Tolerances
 EN 10029:2010 CLASS C

Tekniset vaatimukset ja/tai viralliset määräykset Technical terms of Delivery and/or Official Regulations

Positio Item	Mitat mm Dimensions mm	Merkki Marke	Kpl Pcs	Paino kg Weight kg	Sulatus levy nro Cast plate No	SP nro SP No	UT	MT
-----------------	---------------------------	-----------------	------------	-----------------------	-----------------------------------	-----------------	----	----

NORMALIZED STEEL PLATES
FLATNESS MAX 6MM/M. .SURFACE CONDITION EN 10 163-2:2005 CLASS B3

001	5.00 X 2000	X	6000	2100173113			3	1440	45256	141	141
001	5.00 X 2000	X	6000				2	960	45256	641	641
001	5.00 X 2000	X	6000				2	960	45256	642	642

*** 7 3360

Raabe Steel Works

Testaus ja tarkastus Testing and Inspection

MINNA VALKAMA

Valtuutettu tarkastaja Authorized inspection representative

This is to certify that the material described above has been manufactured and tested with satisfactory results in accordance with the above mentioned standard and Quality.

This Mill Sheet and Test Certificate is issued by the manufacturer in accordance with the arrangements authorized by Lloyd's Register EMEA in a Manufacturing Survey Agreement based on LR Materials Quality Scheme MQS 007. I certify that these arrangements are being kept under review by regular and systematic auditing of the approved manufacturing and Quality Control Procedures.

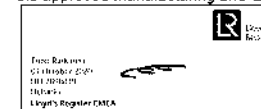
 Yhtiön nimi Company Name: SSAB Europe Oy
 Kotipaikka Registered Office: HÄMEENLINNA

 Osoite Address: PL 93, P.O Box 93
 FIN-92101 RAAHE, FINLAND

 Puhelin Telephone: 020 5911
 +358 20 5911

Y-lunnus Business ID: 2389445-7

Sulatus nro Cast No Schmelzen Nr No de coulée № Плавки	Koe nro Test No Prüf Nr. Essai No № Пробы	Positio Item Pos. Poste Поз.	Cekv Ceq Câq Cég Секв	Analyysi % Chemical composition % Chemisch Zusammensetzung % Composition Chimique % Анализ плавки % (*=ppm)														Päivämäärä Date Datum Date Дата		
				C	SI	MN	P	S	AL	NB	V	TI	CU	CR	NI	MO	N	B	25.09.2020	MLK
45256		001	.32	.144	.26	0.99	.011	.003	.026	.000	.006	.003	.008	0.04	0.04	.004	.006	.0003		

CEQ=C+Mn/6+(Cr+Mo+V)/5+(Ni+Cu)/15

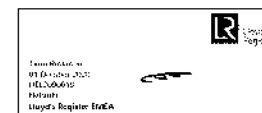

Raabe Steel Works

Testaus ja tarkastus Testing and Inspection Испытание и контроль качества
Prüfung und Kontrolle Essais et Contrôle

Steel manufactured and supplied by Raabe Steel Works is free from radiation.
Производимая на металлургическом комбинате «Raabe Steel Works» и поставляемая
заказчику сталь не излучает радиации.

Minna Valkama

MINNA VALKAMA

Valtuutettu tarkastaja Authorized inspection representative Уполномоченный инспектор
Sachverständiger Inspecteur autorisé

Yhtiön nimi Company Name: SSAB Europe Oy Osoite Address: PL 93, P.O Box 93
Kotipaikka Registered Office: HÄMEENLINNA FIN-92101 RAAHE, FINLAND

Puhelin Telephone: 020 5911
+358 20 5911

Y-tunnus Business ID: 2389445-7



Project:

Client: SSAB Europe Oy, Raahе Steel Works,
Raahе, Finland

Office: Helsinki

Clients Order Number: A19617

Date: 25 September 2020

Order Status: Complete

Inspection Dates

First: 25 September 2020

Final: 25 September 2020

This certificate is issued to SSAB Europe Oy, Raahе Steel Works to certify that the material described herein has been accepted at their works.

The material inspected was stated intended for BE GROUP OY AB, PL 54,
15101 LAHTI FINLAND, against their order number P083419.

Description: Seven (7) HOT ROLLED STEEL PLATES
For details see the attached manufacturer's inspection certificate no. A19617-002B.

Specification: SA516 GR 60 MTLTV ASME SA-516-2019 TOLERANCES ACC. TO EN 10029:2010 CLASS C

Scope of inspection carried out:

This certificate is based on Lloyd's Register's Materials Quality Scheme MQS 007
which is audited three times a year.

Manufacturer's Inspection Certificate and Test Report reviewed and endorsed (attached).

Material inspected by Manufacturer.

Identification of plates: Manufacturer's Brand, Quality, Cast No. and LR

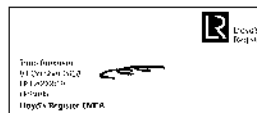

Timo Rinkinen
Surveyor to Lloyd's Register EMEA

A subsidiary of Lloyd's Register Group Limited

Lloyd's Register Group Limited, its affiliates and subsidiaries and their respective officers, employees or agents are, individually and collectively, referred to in this clause as 'Lloyd's Register'. Lloyd's Register assumes no responsibility and shall not be liable to any person for any loss, damage or expense caused by reliance on the information or advice in this document or howsoever provided, unless that person has signed a contract with the relevant Lloyd's Register entity for the provision of this information or advice and in that case any responsibility or liability is exclusively on the terms and conditions set out in that contract.

Form 1123Local (2013 12)

Tilaja Purchaser
BE GROUP OY AB
PL 54
15101 LAHTI FINLAND

Vastaanottaja Consignee
BE GROUP OY AB
PAAKARLANTIE 3
20240 TURKU FINLAND

Päivämäärä Date
25.09.2020 HEL 2090019/11.A

Tilaus nro Order No.
P083419

Tilausvahvistus Order Confirmation
19617

Asiakkaan merkki Shipping mark

Valmistajan merkki
Mark of the Manufacturer



Todistus Certificate
4C0LR

Laivaus Shipping

Laatumerkintä Quality Marking
SA516GR60MTLV

Tarkastajan feima
Stamp of Inspector

Mxx

LR

Toimitustyyppi Delivery type
REST DELIVERY

Sulatus nro levy nro Cast No. Plate No.
XXXXX XXX XX XXX

Vastaanottajan feima
Stamp of Surveyor

Muut leimaukset
Other Stamps

Tuote Product
HEAVY PLATES
Laji Grade
SA516 GR 60 MTLTV ASME SA-516-2019
Laatuselvitys Quality Specifications
PRESS.VESSEL STEEL ASME CODE SEC II ED 2019 SA20

Toleranssit Tolerances
EN 10029:2010 CLASS C

Tekniset vaatimukset ja/tai viralliset määräykset Technical terms of Delivery and/or Official Regulations

Positio Item	Mitat mm Dimensions mm	Merkki Marke	Kpl Pcs	Paino kg Weight kg	Sulatus levy nro Cast plate No	SP nro SP No	UT UT	MT MT
-----------------	---------------------------	-----------------	------------	-----------------------	-----------------------------------	-----------------	----------	----------

NORMALIZED STEEL PLATES

FLATNESS MAX 6MM/M. .SURFACE CONDITION EN 10 163-2:2005 CLASS B3

001	5.00 X 2000	X	6000	2100173113				
			3	1440	45256	141	141	
001	5.00 X 2000	X	6000					
			2	960	45256	641	641	
001	5.00 X 2000	X	6000					
			2	960	45256	642	642	

*** 7 3360

Raabe Steel Works

Testaus ja tarkastus Testing and Inspection

Minna Valkama

MINNA VALKAMA

Valtuutettu tarkastaja Authorized inspection representative

Yhtiön nimi Company Name: SSAB Europe Oy
Kotipaikka Registered Office: HÄMEENLINNA

Osoite Address: PL 93, P.O Box 93
FIN-92101 RAAHE, FINLAND

Puhelin Telephone: 020 5911
+358 20 5911

This Mill Sheet and Test Certificate is issued by the manufacturer in accordance with the arrangements authorized by Lloyd's Register EMEA in a Manufacturing Survey Agreement based on LR Materials Quality Scheme MQS 007. I certify that these arrangements are being kept under review by regular and systematic auditing of the approved manufacturing and Quality Control Procedures.

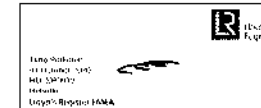

Y-lunnus Business ID: 2389445-7

Tilaja Purchaser
BE GROUP OY AB
PL 54
15101 LAHTI FINLAND
Tilaus nro Order No.
P083419

Tilausvahvistus Order Confirmation
19617

Vastaanottaja Consignee
BE GROUP OY AB
PAAKARLANTIE 3
20240 TURKU FINLAND
Asiakkaan merkki Shipping mark

Päivämäärä Date
25.09.2020 MLK

Valmistajan merkki
Mark of the Manufacturer



Laji Grade
SA516 GR 60 MTLTV

Lisävaatimukset Additional requirements

Jatkuvavalettua happiterästä
Oxygen steel, continuous casting

Laatuselitys Quality Specifications

PRESS.VESSEL STEEL ASME CODE SEC II ED 2019 SA20

Fully killed, Fine grain practiced

N 900C,T=1.1(MIN)XTHICKN(MM)

Pos. Item	Sulatus k. erä nro Cast. test No	T-tila Cond	Tensile test													Taivutuskoee Bend test		Huom Nb	Päästö Tempering °C						
			K2	°C	RP02 MPa	RT05 MPa	REL MPa	REH MPa	1	RM MPa 2	3	50	A % 80	200	RE / RM	RM * A5	1			RAZ % 2	3	Keskiarvo Average	K5	D = X t	
001	45256 141	N F1			339			349	477				38		27										
001	45256 641	N F1			336			344	469				41		29										
001	45256 642	N F1			341			351	475				43		31										

K2: F1=TOP,TRANSV.

N=NORMALIZED

Pos. Item	Sulatus k. erä nro Cast. test No	Iskukoe Impact test				FA %			LE (mm)			Eriskokeet Special tests				Huom Nb	Päästö Tempering °C		
		K3	°C	1	2	3	Keskiarvo Average	W (mm)	1	2	3	Keskiarvo Average	K4	°C	1			2	Keskiarvo Average
001	45256 141	V1E	-051	28	27	26	27												
001	45256 641	V1E	-051	44	44	47	45												
001	45256 642	V1E	-051	43	39	42	41												

K3: V1E=CH-V(JYA/SA370,2.5X10, TOP, LONGIT.

Raah Steel Works

Täten todistamme, että toimitus on tilausvahvistuksen mukainen.
We hereby certify that the material described above has been tested and complies with the terms of the order confirmation.

Testaus ja tarkastus Testing and Inspection

Minna Valkama

MINNA VALKAMA

Valtuutettu tarkastaja Authorized inspection representative

Yhtiön nimi Company Name: SSAB Europe Oy
Kotipaikka Registered Office: HÄMEENLINNA

Osioite Address: PL 93, P.O Box 93
FIN-92101 RAAHE, FINLAND

Puhelin Telephone: 020 5911
+358 20 5911

Y-tunnus Business ID: 2389445-7

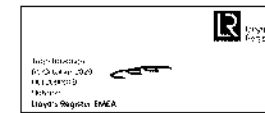

Sulatus nro Cast No Schmelzen Nr No de coulée № Плавки	Koe nro Test No Prüf Nr. Essai No № Пробы	Positio Item Pos. Poste Поз.	Cekv Ceq Câq Cég Секв	Analyysi % Chemical composition % Chemisch Zusammensetzung % Composition Chimique % Анализ плавки % (*=ppm)														Päivämäärä Date Datum Date Дата		
				C	SI	MN	P	S	AL	NB	V	TI	CU	CR	NI	MO	N	B	25.09.2020	MLK
45256		001	.32	.144	.26	0.99	.011	.003	.026	.000	.006	.003	.008	0.04	0.04	.004	.006	.0003		

CEQ=C+Mn/6+(Cr+Mo+V)/5+(Ni+Cu)/15

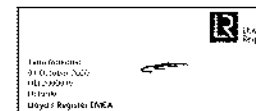

Raabe Steel Works

Testaus ja tarkastus Testing and Inspection Испытание и контроль качества
Prüfung und Kontrolle Essais et Contrôle

Steel manufactured and supplied by Raabe Steel Works is free from radiation.
Производимая на металлургическом комбинате «Raabe Steel Works» и поставляемая заказчику сталь не излучает радиации.

Minna Valkama

MINNA VALKAMA

Valtuutettu tarkastaja Authorized inspection representative Уполномоченный инспектор
Sachverständiger Inspecteur autorisé

Yhtiön nimi Company Name: SSAB Europe Oy Osoite Address: PL 93, P.O Box 93
Kotipaikka Registered Office: HÄMEENLINNA FIN-92101 RAAHE, FINLAND

Puhelin Telephone: 020 5911
+358 20 5911

Y-tunnus Business ID: 2389445-7

Tilaja Purchaser
BE GROUP OY AB
PL 54
15101 LAHTI FINLAND

Vastaanottaja Consignee
BE GROUP OY AB
PAAKARLANTIE 3
20240 TURKU FINLAND

Päivämäärä Date
25.09.2020

Tilaus nro Order No.
P083419

Tilausvahvistus Order Confirmation
19617

Asiakkaan merkki Shipping mark

Valmistajan merkki
Mark of the Manufacturer



Todistus Certificate
4A1TUV

Laivaus Shipping

Laatumerkintä Quality Marking
P265GH

Tarkastajan leima
Stamp of Inspector

Mxx

Toimitustyyppi Delivery type
REST DELIVERY

Sulatus nro levy nro Cast No. Plate No.
X X X X X X X X X X X X X X X

Vastaanottajan leima
Stamp of Surveyor

Muut leimaukset
Other Stamps

Tuote Product
HEAVY PLATES
Laji Grade
P265GH EN 10028-2:2017
Laatuselvitys Quality Specifications
PRESSURE VESSEL STEEL

Toleranssit Tolerances
EN 10029:2010 CLASS C

Tekniset vaatimukset ja/tai viralliset määräykset Technical terms of Delivery and/or Official Regulations

PED 2014/68/EU/AD 2000-W1

Positio Item	Mitat mm Dimensions mm	Merkki Marke	Kpl Pcs	Paino kg Weight kg	Sulatus levy nro Cast plate No	SP nro SP No	UT	MT
-----------------	---------------------------	-----------------	------------	-----------------------	-----------------------------------	-----------------	----	----

NORMALIZED STEEL PLATES

FLATNESS MAX 6MM/M. .SURFACE CONDITION EN 10 163-2:2005 CLASS B3

001	5.00 X 2000	X	6000	2100173113	3	1440	45256	141	141
001	5.00 X 2000	X	6000		2	960	45256	641	641
001	5.00 X 2000	X	6000		2	960	45256	642	642

*** 7 3360

BESICHTIGUNG UND MASSKONTROLLE OHNE FEHLBEFUND

Raabe Steel Works

Testaus ja tarkastus Testing and Inspection

Täten todistamme, että toimitus on tilausvahvistuksen mukainen.
We hereby certify that the material described above has been tested and complies with the terms of the order confirmation.

Approved acc. to AD 2000-Merkblatt W 0 and certified acc. to PED (2014/68/EU) by
Notified Body for Pressure Equipment of TÜV NORD Systems GmbH & Co. KG
(Reg. No.: 0045).

Minna Valkama

MINNA VALKAMA

Valtuutettu tarkastaja Authorized inspection representative

Yhtiön nimi Company Name: SSAB Europe Oy
Kotipaikka Registered Office: HÄMEENLINNA

Osoite Address: PL 93, P.O Box 93
FIN-92101 RAAHE, FINLAND

Puhelin Telephone: 020 5911
+358 20 5911

Y-lunnus Business ID: 2389445-7

Tilaja Purchaser
BE GROUP OY AB
PL 54
15101 LAHTI FINLAND
Tilaus nro Order No.
P083419

Tilausvahvistus Order Confirmation
19617

Vastaanottaja Consignee
BE GROUP OY AB
PAAKARLANTIE 3
20240 TURKU FINLAND
Asiakkaan merkki Shipping mark

Päivämäärä Date
25.09.2020 MLK

Valmistajan merkki
Mark of the Manufacturer



Laji Grade
P265GH

Lisävaatimukset Additional requirements

Jatkuvavalettua happiterästä
Oxygen steel, continuous casting

Laatuselitys Quality Specifications
PRESSURE VESSEL STEEL

PED 2014/68/EU/AD 2000-W1

Fully killed, Fine grain practiced

Pos. Item	Sulatus k. erä nro Cast. test No	T-tila Cond	Vetokoe Tensile test											Taivutuskoee Bend test		Huom Nb	Päästö Tempering °C						
				K2	°C	RP02 MPa	RT05 MPa	REL MPa	REH MPa	1	RM MPa 2	3	50	A % 80	200			RE / RM	RM * A5	1	RAZ % 2	3	Keskiarvo Average
001	45256 141	N	F1			339					349	477			38						27		
001	45256 641	N	F1			336					344	469			41						29		
				1C	+300	229																	
001	45256 642	N	F1			341					351	475			43						31		

K2: F1=TOP,TRANSV. 1C=RP0.2

N=NORMALIZED

Pos. Item	Sulatus k. erä nro Cast. test No	Iskukoe Impact test	FA %					LE (mm)			Erikoiskokeet Special tests					Huom Nb	Päästö Tempering °C						
			K3	°C	1	2	3	Keskiarvo Average	W (mm)	1	2	3	Keskiarvo Average	K4	°C			1	2	Keskiarvo Average			
001	45256 141	118	-020	102	100	101	101																
001	45256 641	118	-020	120	118	113	117																
001	45256 642	118	-020	141	119	131	130																

K3: 118=CH-V(J),TX10, TOP, TRANSV, KV600

Raabe Steel Works

Täten todistamme, että toimitus on tilausvahvistuksen mukainen.
We hereby certify that the material described above has been tested and complies with the terms of the order confirmation.

Testaus ja tarkastus Testing and Inspection

MINNA VALKAMA

Valtuutettu tarkastaja Authorized inspection representative

Yhtiön nimi Company Name: SSAB Europe Oy
Kotipaikka Registered Office: HÄMEENLINNA

Osioite Address: PL 93, P.O Box 93
FIN-92101 RAAHE, FINLAND

Puhelin Telephone: 020 5911
+358 20 5911

Y-tunnus Business ID: 2389445-7

Sulatus nro Cast No Schmelzen Nr No de coulée № Плавки	Koe nro Test No Prüf Nr. Essai No № Пробы	Positio Item Pos. Poste Поз.	Cekv Ceq Câq Cég Секв	Analyysi % Chemical composition % Chemisch Zusammensetzung % Composition Chimique % Анализ плавки % (*=ppm)														Päivämäärä Date Datum Date Дата		
				C	SI	MN	P	S	AL	NB	V	TI	CU	CR	NI	MO	N	B	25.09.2020	MLK
45256		001	.32	.144	.26	0.99	.011	.003	.026	.000	.006	.003	.008	0.04	0.04	.004	.006	.0003		

CEQ=C+Mn/6+(Cr+Mo+V)/5+(Ni+Cu)/15

Raahe Steel Works

Testaus ja tarkastus Testing and Inspection Испытание и контроль качества
Prüfung und Kontrolle Essais et Contrôle

Steel manufactured and supplied by Raahe Steel Works is free from radiation.
Производимая на металлургическом комбинате «Raahe Steel Works» и поставляемая
заказчику сталь не излучает радиации.



MINNA VALKAMA

Valtuutettu tarkastaja Authorized inspection representative Уполномоченный инспектор
Sachverständiger Inspecteur autorisé

Yhtiön nimi Company Name: SSAB Europe Oy Osoite Address: PL 93, P.O Box 93
Kotipaikka Registered Office: HÄMEENLINNA FIN-92101 RAAHE, FINLAND

Puhelin Telephone: 020 5911
+358 20 5911

Y-tunnus Business ID: 2389445-7

IMATRA

26.8.2020

461291

SE5971

Digitally protected by Ovako

Customer's order number 015094		Manufacturer's order number 157342 1		
Customer/consignee Ovako Metals Oy Ab Tuotekatu 3 33840 Tampere		Buyer Ovako Metals Oy Ab Tuotekatu 3 33840 Tampere		
Customer reference number 015094-5130/96-721009				
Product Round bar As rolled Hot rolled, cold drawn		Steel grade IMATRA 550		
		Specification IS 2722.01.05		
Charge 40640	Abbreviation Z2P	Diameter/dimensions 40 mm	Tolerance type h09	Reduction ratio 82,83 :1

CAST ANALYSIS

	C %	SI %	MN %	P %	S %	CR %	NI %	MO %	
Min					0,020				
Result	0,13	0,23	1,14	0,007	0,033	0,12	0,15	0,06	
Max	0,20	0,55	1,60	0,025	0,040				
	V %	TI %	CU %	ALS %	AS %	SN %	B %	CA %	
Min								0,0020	
Result	0,05	0,0014	0,25	0,009	0,008	0,012	0,0002	0,0045	
Max	0,09		0,30						
	N %	NB %	CO %	PB %	W %	SB %	CEV %		
Min									
Result	0,014	0,002	0,014	0,0016	0,005	0,003	0,39		
Max							0,47		

TENSILE TEST FROM 1/3 RADIUS EN ISO 6892-1

	Rp0.2 MPa	Rm MPa	A %	Z %
Min	500	550	12	
Result	671	681	14	61
Max		750		

This material meets also the requirements of S355J2C+C according to EN 10277:2018
Steel production process: Electric Arc Furnace, Vacuum Degassing and Continuous Casting

Country of origin: Finland

The products supplied are in compliance with the requirements of the order

This certificate is issued electronically and is valid without a signature

26.8.2020

461291

Customer's order number 015094	Manufacturer's order number 157342 1			
Customer/consignee Ovako Metals Oy Ab Tuotekatu 3 33840 Tampere	Buyer Ovako Metals Oy Ab Tuotekatu 3 33840 Tampere			
Customer reference number 015094-5130/96-721009				
Product Round bar As rolled Hot rolled, cold drawn	Steel grade IMATRA 550			
	Specification IS 2722.01.05			
Charge 40640	Abbreviation Z2P	Diameter/dimensions 40 mm	Tolerance type h09	Reduction ratio 82,83 :1

Takala Esa
Authorized Representative

Certificate of Final Inspection

For pressure equipment

Order No: **T21/16**
The product: **Plate & Shell Heat Exchanger**
Manufacturing No: **61132**
Type: **3HH-66/2/1**
Conformity assessment:

Design

According to the Technical Data Sheet of the product.

Materials

Checked the marking and traceability of materials of main pressure bearing parts to the material certificates.

Welding

Visually checked according to EN ISO 17637
In accordance with EN ISO 5817, quality level C
Checked welding log and welder signs.

Non-destructive testing

Required non-destructive testing has been carried out satisfactory.

Pressure test

		Plate pack*	Shell
Design pressure	kPa	-100 / 2 799	-100 / 2 799
Test pressure	kPa	4 020	4 020
Pressuring fluid		Water	Water
Pressure holding time	min	30	30
Carried out by		R. Laakso	R. Laakso
Date		15.04.2021	15.04.2021

Remarks

*Plate stack tested externally.

To certify the satisfactory inspection

Digitally signed for and behalf of:



VAHTERUS

Plate & Shell Heat Exchanger
23600 Kalanti Finland



Tipo
Type

PSHE 3HH-66/2/1

Ano construído
Year built

Fabricante/Nr.
Manuf. Nr.

61131

Lado das placas
Plate side

Lado do casco
Shell side

Pressão de projeto (min/máx)
Design pressure (min/max)

-100/2799

kPa(g)
(kgf/cm²)

(-1/28.5)

-100/2799

kPa(g)
(kgf/cm²)

(-1/28.5)

PMTA (corroído e quente)
MAWP (hot and corroded)

2799 (28.5)

kPa(g)
(kgf/cm²)

2799 (28.5)

kPa(g)
(kgf/cm²)

Temperatura de projeto
Design temperature (min/max)

0/130

°C

0/130

°C

Volume

5.2

L

8.1

L

Pressão de teste hidrostático
Test pressure

4020 (41.0)

kPa(g)
(kgf/cm²)

4020 (41.0)

kPa(g)
(kgf/cm²)

Data do teste
Test date

Médo
Medium

Óleo

Oil

Refrigerante / Água

Refrigerant / Water

Peso (vazio/in operation)
Weight (empty/in operation)

105 / 118

Kg

Norma de projeto/ano ed
Design code

PED 2014/68/EU + AD 2000 Calculation + NIR-13

Categoria/Grupo/Classe
Category/Group/Class

IV / 5 / B

Sobrepresura de corrosão
Corrosion Allowance

SS: 0 CS: 1

mm

Materiais
Materials

AISI316L (Placas) P236GH

VAHTERUS

User Manual for Vahterus Plate & Shell Heat Exchangers

English

VAHTERUS

User Manual for Vahterus Plate & Shell Heat Exchangers

Contents

1	General	7
1.1	Introduction	7
1.2	Products	8
1.3	Structure	11
1.4	Technical specifications	11
2	Assembly of the Heat Exchanger	13
2.1	Lifting	13
2.2	Pipes	14
2.2.1	General	14
2.2.2	Steam application (Condensers)	16
2.3	Insulation	17
2.4	Pressure test	17
2.5	Mounting brackets	18
3	Permitted Conditions for Operating	19
3.1	Design	19
3.2	Fluids	20
3.3	Flow rates	22
4	Operation	23
4.1	Principle of the Heat Exchanger	23

4.1.1	Liquid–Liquid	24
4.1.2	Condenser	25
4.1.3	DX-Evaporator	25
4.1.4	Flooded Evaporator	26
4.1.5	Droplet Separator	27
4.1.6	Steam Generator (Kettle)	28
4.1.7	Exhaust Gas Economiser (EGE)	28
4.2	General start-up	29
4.3	General shut down	30
4.4	Start-up and shut down of steam applications	31
4.5	Recommended periodical inspections of PSHEs	36
5	Cleaning the Heat Exchanger	37
5.1	General	37
5.2	Recommendations for cleaning	38
5.2.1	Backwards flow	39
5.2.2	Chemical cleaning	40
5.2.3	Mechanical cleaning	41
5.2.4	Analysis after cleaning	42
5.3	Openable model	42
5.3.1	Preparations	43
5.3.2	Opening the exchanger and removing the plate pack	43
5.3.3	Mounting the plate pack	45
5.3.4	Bolt/nut tightening pattern	46
6	Expandable Plate Pack	47
7	Spare Parts / Special Tools	48
8	Packing and Storage	48

VAHTERUS

9	Troubleshooting	51
9.1	Complaints report	56
9.2	Measures for replacement	56
9.3	Information about the repair	56
9.4	Criteria of limiting conditions for the equipment	57
10	Recycling	57

1 General

1.1 Introduction

The operating instructions for the Vahterus Plate & Shell Heat Exchangers (PSHEs) are made up of the Technical Data sheet, Dimensional Drawing and this Operation & Maintenance manual.

This manual is your general guide to the proper installation, operation and maintenance of the Vahterus Plate & Shell Heat Exchanger and PSHE droplet separator. Please read it and follow the instructions carefully. Vahterus accepts no liability for damage caused by the incorrect installation, operation or maintenance of the unit.

1.2 Products



Plate & Shell Fully Welded

A welded pack of circular plates inside a welded pressure vessel. The applications for this type are liquid–liquid, condenser, evaporator and cascade. This model cannot be opened. It can be single or multi pass. (See Chapter 4.1: Principle of Heat Exchanger)



Plate & Shell Openable

A fully welded and removable plate pack inside an openable shell.



Plate & Shell Compact

All connections are on the end plate.
Can be single or multi pass.



Plate & Shell VES

Heat exchanger with external droplet separator.

1.2 Products continues from last page:



Plate & Shell Combined

Heat exchanger with combined droplet separator.



Plate & Shell EGE

Exhaust gas economiser.

1.3 Structure

Vahterus Plate & Shell Heat Exchangers are designed and manufactured in compliance with legislation relating to pressure equipment. The design code used is given on the Vahterus Technical Data sheet. The codes generally used are:

- ASME VIII Div.1, based on an individual design for each heat exchanger.
- Pressure Equipment Directive (CE): the design is based on PED classification and modules, e.g. type approvals by NoBo.

1.4 Technical specifications

General range of parameters:

- Volume: from 0.0002 m³ to 5 m³.
- Temperature: from -196°C to +600°C.

Pressure:

- 10 / 16 / 25 / 40 / 60 bar(g) standard range
- up to 170 bar(g) on request

Materials:

- Carbon Steel (P235GH, P265GH, P355NL2, SA516Gr70, SA333 etc.)
- AISI 316/316L, 1.4404 / 304L, 1.4403
- Titanium Gr. 1

VAHTERUS

- Hastelloy (C22 & C276)
- Nickel 201
- SMO 254, EN 1.4547
- AISI 904, EN 1.4539
- Duplex, EN 1.4462
- Other materials on request

Working mediums:

- Liquid of all groups
- Gas of all groups
- Steam (superheated & saturated) of all groups
- 2 phase mediums (i.e. liquid-gaseous mixture) of all groups



- Refrigerants group 1
 - *R170 (ethane)*
 - *R1150 (ethylene)*
 - *R290 (propane)*
 - *R717 (ammonia)*
 - *R1270 (propylene)*

- Refrigerants group 2
 - *R134a*
 - *R744 (CO₂)*
 - *R404a*
 - *R410a*
 - *R407F*
 - *R507a*
 - *All the other refrigerants from group 2*

2 Assembly of the Heat Exchanger

2.1 Lifting

Plenty of space should be provided around the heat exchanger for mounting, insulation and maintenance. With the openable model, there should be available space equal to the total length at the front in order to remove the plate pack. Ensure that there is adequate space above the heat exchanger in order to lift it freely. Most of the heat exchangers are provided with welded lifting lugs or lifting eye lugs. If lifting lugs are not provided, lift the heat exchanger with a textile belt around the shell.

Lifting (eye) lug 	Lifting force (direct lift) 
1t (welded)	1,000 kg
3t (welded)	3,000 kg
5t (welded)	5,000 kg
7t (welded)	7,000 kg
M16 (DIN 582)	700 kg
M20 (DIN 582)	1,200 kg

NB

When heat exchangers are combined with droplet separators, their considerable overall weight should be taken into account, and the lifting gear and lugs must be in the correct range. It is essential that the entire unit is supported by a crane or hoist, using the lugs, until it is bolted into position. If necessary, the combined unit can be provided with permanent extra support by fixing the lugs to the surrounding support structures.

Do not use the mounting brackets or nozzles to lift the heat exchanger.

Vahterus will assist in the planning of the lifting if needed, and separate lifting instructions are available. Please contact Vahterus Service.

WARNING!

Do not weld anything to the heat exchanger (including the shell, end plates and the sides of the pipes) without the manufacturer's permission, since this could undermine the durability of its pressure envelope and internal structures.

2.2 Pipes

2.2.1 General

Install the unit so that the piping and heat exchanger can be drained easily. The heat exchanger is not normally provided with separate drain and ventilation connections. If your process requires these, they should be installed in the pipelines as close as possible to the heat exchanger, or, if it is necessary to have them installed in the exchanger, this should be specified when the exchanger is ordered.

Ensure the following:

1. All piping to be fixed to the exchanger is to be flushed prior to connecting the unit.
2. All connections are marked and should be connected according to the GA drawing.
3. The piping system must be flexible so that thermal expansion does not overload the nozzles and so that the heat exchanger is not subjected to vibration.
4. All pipe connections to and from the heat exchanger must be equipped with shut-off valves. Those with slow valve action are recommended. It should be possible to increase and reduce flow rates gradually when the system is being shut down or started.
5. If there are solids in the process fluids, the use of filters is recommended. Further information is available from Vahterus Service.
6. The piping must be equipped with a relief valve to prevent unintentional excess of design pressure.
7. If multiple units are being arranged in parallel, the flow should be evenly distributed amongst the exchangers.

Openable model:

Connections between the plate pack on the openable model and the pipes must be made either with flange or threaded connections.

2.2.2 Steam Application (Condensers)

The pipelines should be manufactured according to best steam flow manufacturing practices. In steam applications the unit is placed horizontally to prevent condensate from remaining on the surface of the plates. It is recommended that, where necessary, a steam trap (drain) is installed in front of and behind the heat exchanger and a droplet separator in front of it. The separator in front of the exchanger should be installed before the valve. This will prevent condensate from accumulating behind the valve.

When the water vapour is on the shell side, the heat exchanger is provided with a striker plate, which is welded to the HOT IN connection to prevent water hammer. However, additional measures should be taken to prevent water hammer in the heat exchanger.

WARNING!

When the valve is closed, condensate might accumulate in the steam pipeline if no attention has been paid to drainage. When the valve is opened, accumulated water passes into the heat exchanger at high speed, possibly resulting in mechanical damage.

NB

If the exchanger is operating in a partial vacuum or if the pressure on the steam side is able in some cases to lower the pressure on the condensate side, the use of a condensate pump should be considered.

When a condensate side control is being used, the condensation temperature on the hot side must be no higher than the evaporating temperature on the cold side; e.g. if there is water on the cold side, the pressure of the steam must be lower than the pressure of the water, to prevent the water from boiling.

2.3 Insulation

If the temperature on the shell side is below -10°C or above 65°C, insulation is recommended to avoid burns or frostbite.

2.4 Pressure test

All PSHE units have been pressure-tested, as follows:

- a)** all plate packs – leak test (pneumatic pressure test under water)
- b)** whole unit – hydraulic pressure test

If you need to perform a pressure test prior to using the heat exchanger, the test pressure is given on the Technical Data sheet and on the nameplate.

The pressure should be increased slowly to prevent pressure shocks. During manufacturing, in certain cases water is not an acceptable pressurising medium for the media (refrigerant or oils) in the user's process, so the pressure test is waived and an additional NDE is carried out on the welds.

NB

Pressure testing of the plate pack in the openable heat exchanger should always be carried out with the plate pack positioned in the shell and the bolts on the cover plate tightened, in accordance with the instructions in this manual. When pneumatic leak or pressure testing is being carried out, ensure that conditions are safe, given the possibility that there could be a pressure discharge similar to an explosion should the heat exchanger or testing equipment break.

Never apply pressure to the plate pack outside the shell.

2.5 Mounting Brackets

Vahterus standard brackets are only designed to bear the weight of the heat exchanger. The design does not allow for specific requirements, such as stress and strain caused by the piping, wind load or earthquakes.

3 Permitted Conditions for Operating

3.1 Design

Never exceed the design pressures and temperatures marked on the nameplate and Technical Data sheet. Ambient temperatures must not be higher/lower than the design temperature range.

Environmental load, load on connections caused by the piping, wind load and earthquakes are not taken into account in the design strength calculations, unless mentioned separately.

The pipework in the heat exchanger and the mounting brackets must not be loaded down by external forces, unless mentioned separately in the strength calculations.

Corrosion allowance is indicated in the strength calculations: for carbon steel it is at least 1 mm. Any greater corrosion allowance requirement must be stated when the heat exchanger is ordered.

Fatigue: 500 full pressure cycles are allowed without separate calculations. If this number is exceeded, you should test the heat exchanger (pressure test and possible NDE tests) with reference to local laws.

Please advise us of any possible risk of external fire.

Safety appliances should be specified/designed and acquired by the customer, since they are not provided by Vahterus.

3.2 Fluids

The structural materials are selected based on the information (media, temperatures, flows) provided by the customer. You can also contact Vahterus for material and flow director material options.

If the heat exchanger is used in conditions that differ from those for which it was designed (listed on the Technical Data sheet), its ability to function must be checked. For example, if the viscosity of the fluid varies according to conditions that differ from the information on the Technical Data sheet and could result in a difference in pressure of more than 200 kPa between the exchanger and the incoming and outgoing connectors, Vahterus should be contacted to re-assess the load situation.

Before approving the heat exchanger materials, please ensure that they will stand up to the conditions to which they will be subjected during his process. Acid-resistant steel is prone to forms of corrosion, e.g. intergranular corrosion, pitting corrosion, stress corrosion and biological corrosion. The chloride content of water can cause corrosion in AISI 316L/ 1.4404 plate materials in a short space of time. When water is boiling, in particular, it causes chloride precipitation and this can lead to corrosion at quite small concentrations.

Other factors causing a risk of corrosion are pH, the liquid's flow rate, dirt on the plate, impurities, etc., whose effect should be assessed for each individual process. If there is a risk of corrosion, more durable materials such as AISI 904L, SMO 254, Duplex or titanium should be considered.

NB

For special instructions regarding the quality of water in steam generators, contact Vahterus Sales. Please inform us if unstable fluids are used in the process.

General recommendation for water quality when AISI 316L plate material is used in +20°C		
Variable	Unit	Recommended quality limits for water for AISI 316L
Hydrogen ion concentration	pH	6-9
Alkalinity (as CaO3)	mg/l	< 300
Chloride	mg/l	< 500 mg/l at 25°C < 200 mg/l at 50°C < 60 mg/l at 80°C 0 mg/l, when T > 100°C * Contact Vahterus when > 100°C
Sulphate	mg/l	< 100
KMnO4 - consumption	mg/kg	< 20
Aluminium	mg/l	< 0.3
Iron (Fe)	mg/l	< 0.3
Manganese	mg/l	< 0.1
Sodium + Potassium	mg/l	< 200
Conductivity	mS/m	< 200
Calcium	mg/l	< 20

3.3 Flow rates

Flow rates should be kept as near as possible to the design values. Lower flow rates can cause unexpected changes to the heat exchanger and make the plate surfaces dirty. If a heat exchanger with essentially greater flow rates is required, please ask us to check the suitability of the exchanger.

4 Operation

4.1 Principle of the Heat Exchanger

The purpose of a heat exchanger is to transfer heat from one to another flow of fluid via a corrugated heat transfer plate.

The construction is such that the flows alternate through the plate pack. The flows can be controlled as counter-current, co-current or cross-flow.

Structure of the Vahterus Plate & Shell heat exchanger

The Plate & Shell heat exchanger consists of circular plates welded into a pack, which is then mounted in a pressure vessel.

The flow on the plate side is through the connections on the end plates via the plate pack.

The flow on the shell side is through the shell connections via the plate pack using a flow director.

The construction may be either fully welded or openable. The openable type has a removable cover plate so that the plate pack can be taken out.

The following are the various applications of a PSHE exchanger:

4.1.1 Liquid-Liquid

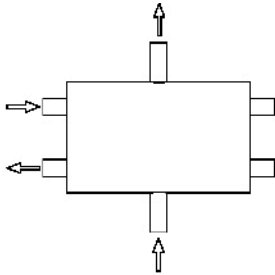

1-pass

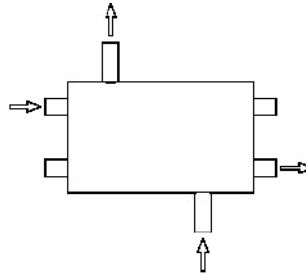

1, 3-pass

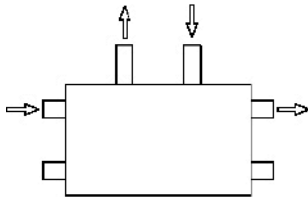

2, 4-pass

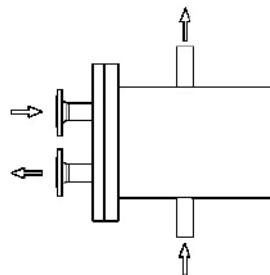

1-pass openable

In liquid-liquid applications, the hot and cold sides can be mounted to either side of the exchanger. In general, the hot side will be on the plate side and the cold liquid on the shell side. Both sides are clearly marked on the drawings and heat exchangers. General recommendation for flow directions are hot side down and cold side up, but special directions can be specified during heat exchanger heat transfer calculation.

4.1.2 Condenser

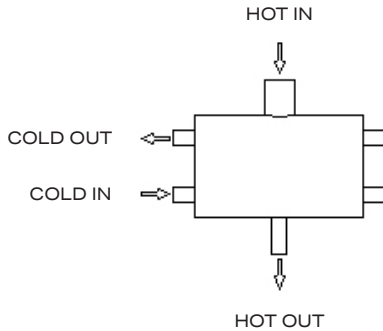

In condensing applications, the steam is on the shell side, with the cold side on the plate side. Shell side (steam) flow enters the exchanger at the top of the shell and the condensate exits at the bottom. Plate side flow is counter-current: the exchanger operates on the counter-current principle. Steam on the end plate side/cold side in the shell and vent condenser designs are also possible.

4.1.3 DX-Evaporator

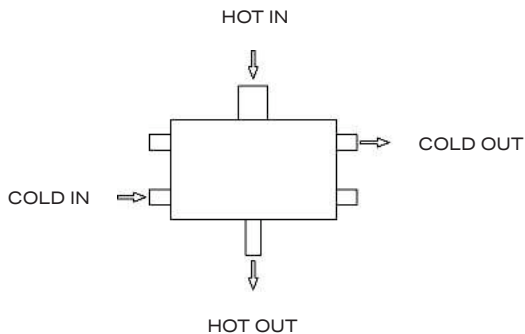

4.1.3 DX-Evaporator continues from last page:

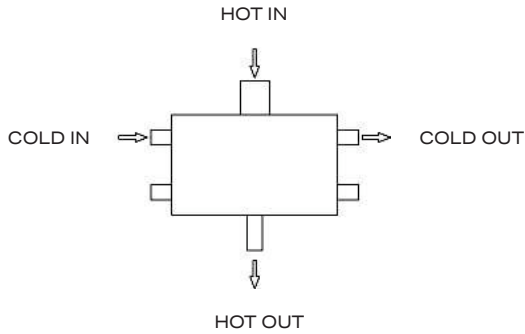

Evaporation always takes place on the plate side and cooling on the shell side.

4.1.4 Flooded Evaporator

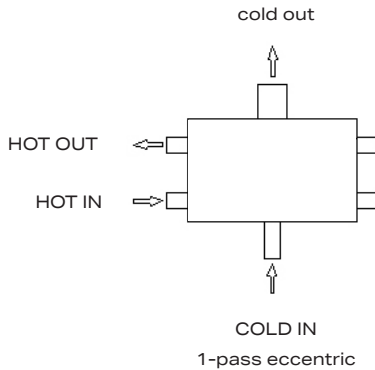

Evaporation generally takes place on the shell side. With special applications, however, it can take place on the pack side.

4.1.5 Droplet Separator

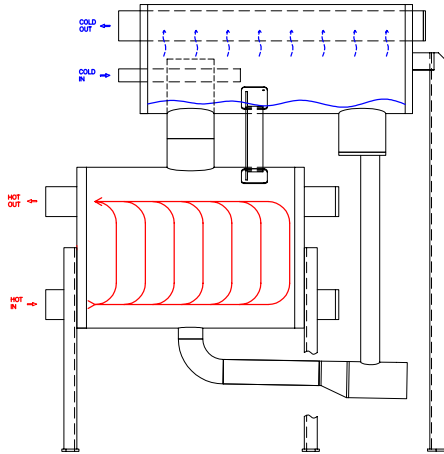

The heat exchanger system is the same as in 4.1.4, with the addition of a droplet separator and recirculation pipe.

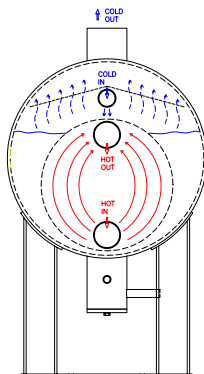

In the combined heat exchanger the droplet separator is integrated within the exchanger's shell.

VAHTERUS

4.1.6 Steam Generator (Kettle)

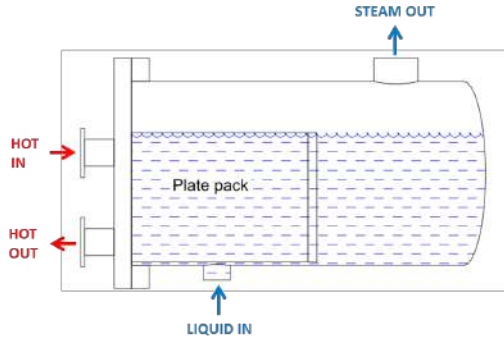
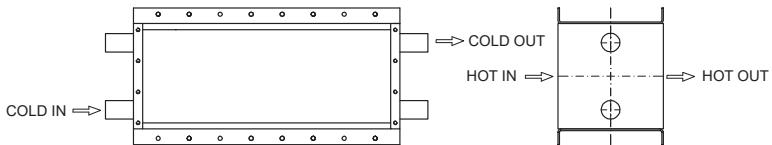

Plate pack positioned in large shell. Steam generator application.

4.1.7 Exhaust Gas Economiser (EGE)



For cooling or heating gases.

4.2 General start-up

The following instructions are general, and process-specific demands must be taken into account by the user.

Check the following before start-up:

- Pipe connections comply with the drawings and are securely supported/fastened.
- Drain valves are closed.
- The heat exchanger and pipelines are properly vented.
- Any safety appliances are correctly connected.
- There are no risk factors in the pipes that could cause shock pressure (water hammer) or sudden changes in pressure.

First, start the flow on the cold side, and then start and gradually increase the flow on the hot side. If there is a risk of freezing, or the liquid being used has high viscosity, the start-up sequence must be checked and determined by the user according to process requirements.

The general heating rate is max. 5°C/minute.

The pressure may be increased gradually. See also section 3.2.

Check the system for pressure pulses caused by pumps or control valves. Continuous pulsing and vibration may cause fatigue in the plates.

VAHTERUS

To begin the heat exchanger process, follow steps a–f, starting first on the cold side. Then repeat for the hot side.

- a) Close the inlet shut-off valve.
- b) Open the outlet shut-off valve.
- c) Open the vent valve, if the heat exchanger is provided with one; otherwise vent from the nearest vent valve to the heat exchanger in the pipework.
- d) Start the pump.
- e) Slowly open the inlet valve according to the instructions.
- f) Close the vent valve when all the air has been removed from the system. If the heat exchanger is working properly, it can be used on an ongoing basis.

Openable model:

When the openable model is being started up, always check the bolts and tighten them if necessary.

4.3 General shut down

If the heat exchanger process is to be halted, follow steps a–d below, starting first on the hot side. Then repeat for the cold side.

- a) Slowly close the inlet valves.
- b) Switch off the pumps.

- c) Close the outlet valves.
- d) Drain and vent the heat exchanger.

Gradually decrease the flow on the hot side until it stops completely. Then close the cold side.

NB

Valves must be set to open gradually. Sudden opening and closing of the valves will subject the exchanger to thermal shock and may cause material fatigue. In steam applications, never leave the hot side on when the liquid side is turned off. Turn the steam OFF first and ON last. In steam processes, it must be noted that cooling water side pressure must be higher than steam pressure in the condensate side controlled unit. If pressure is lower, cooling water can evaporate and there is a risk of plate damage.

4.4 Start-up and shut down of steam applications

It is necessary to vent air off from the heat exchanger before starting the operation. The following procedure should be followed:

Air venting process

1. Close the inlet shut-off valve.
2. Open the outlet shut-off valve.
3. Open the vent valve, if the heat exchanger is provided with one; otherwise, vent from the nearest vent valve to the heat exchanger in the pipeline.

VAHTERUS

4. Start up the pump.
5. Slowly open the inlet valve according to the instructions.
6. Close the vent valve when all the air has been removed from the system.
7. Begin the actual start-up procedure.

After the venting procedure, please check the additional information for different units.

Steam condenser with steam side control:

Be aware: If the cold side flow is turned fully on before opening the steam valve, the steam side start-up will lead to a vacuum condition when starting up.

1. Partly open the cooling water side. All valves must be opened gradually to prevent thermal shocks to the heat exchanger.
2. Check that the heat exchanger and steam lines are empty of condensate if the system is steam side controlled. The condensate outlet pipe also needs to be empty of condensate. To ensure a safe start-up, good condensate level control in the system is recommended.
3. Open the steam valve gradually, allowing condensing to start. The temperature increase must be done step by step, max. 20°C/step, and then allowed to stabilise (the temperature increasing rate at start-up is max. 5°C/minute). The temperature is raised by increasing steam pressure.
4. If the unit is cold (below 0°C), the correct heating rate is 100°C/hour for the first 100°C. After that, the temperature increasing rate is max. 5°/minute.
5. Full capacity is reached by opening both sides gradually to full open position.

Steam condenser with condensate side control:

1. The steam side must be filled with water when starting up the unit.
2. Check that the steam lines are empty of condensate.
3. Partly open the cooling water side. Valves must be opened gradually to prevent thermal shocks to the heat exchanger.
4. Open the steam condensate valve gradually, allowing condensing to start. The temperature increase must be done step by step, max. 20°C/step and then allowed to stabilise (the temperature increasing rate at start-up is max. 5°C/minute). The temperature is raised by increasing pressure. The steam side pressure must always be lower than the cooling side pressure. (Figure 1 and 2)
5. If the unit is cold (below 0°C), the correct heating rate is 100°C/hour for the first 100°C. After that, the temperature increasing rate is max. 5°/minute.

ATTENTION!

- It is not possible to measure the condensate level when the steam condenser is operated with condensate side control.
- In condensate controlled units, the capacity is controlled by controlling the condensate level inside the unit according to the cold side outlet temperature. Condensate temperature cannot be used to control the condensate level inside the unit.

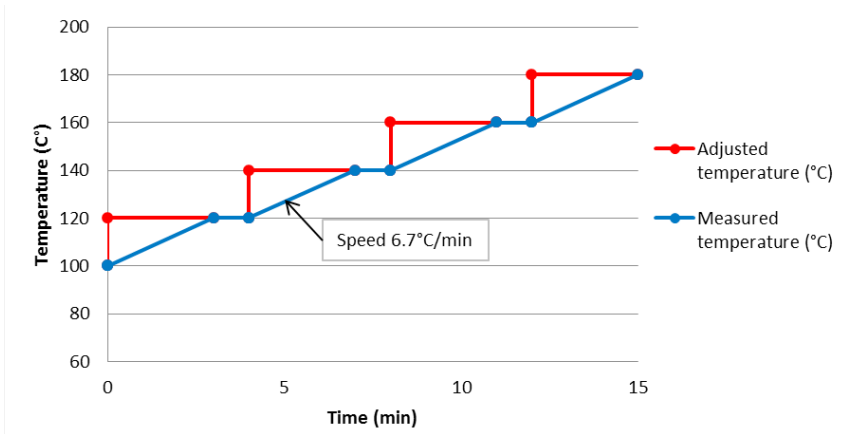

Fig. 1. When the rate of temperature increase is higher than 5°C/minute, the time between the incremental steps has to be taken into account.

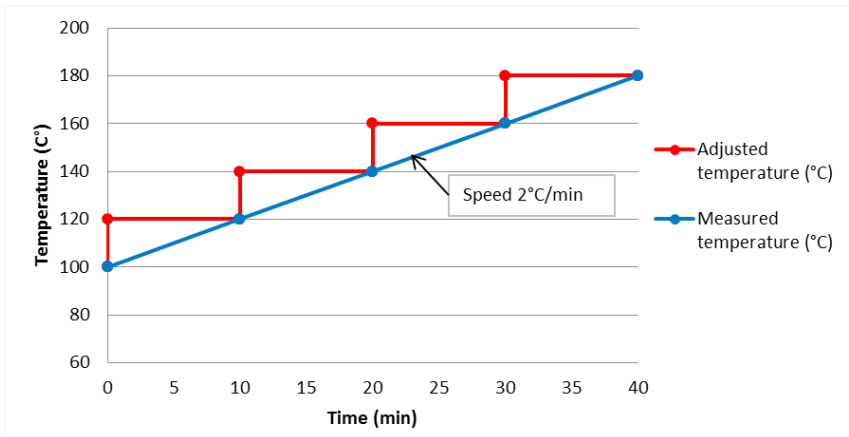

Fig. 2. When the rate of temperature increase is lower than 5°C/minute, the temperature can be increased immediately after it has reached the adjusted temperature.

Steam generator:

1. Check that the heat exchanger cold side is flooded with the condensate before opening the secondary side flow.
2. First, open the hot side to start heating up. Open the valve gradually to prevent thermal shocks.
3. Open the inlet valve of the primary side, allowing liquid to enter the generator. After that, open the outlet valve (start-up valve if any).
4. If the unit is cold, the correct heating speed is 100°C/hour for the first 100°C. After that, the heating rate can be doubled.
5. Gradually continue opening the hot/cold side valves to reach the required capacity.

Shut down:

If the process is to be stopped, begin shutting down the hot side following the steps below, then repeat the same for the cold side.

1. Slowly close the inlet valves. Gradually decrease the flow until it stops completely.
2. Switch off the pumps.
3. Close the outlet valve.
4. Drain and vent the heat exchanger.

4.5 Recommended periodical inspections of Plate & Shell heat exchangers

Fully welded heat exchangers:

After 5 years

- *Internal inspection of shell chamber with endoscope*

After 10 years

- *Pressure test*

Openable heat exchangers:

After 5 years

- *Internal inspection of shell chamber with endoscope*

After 10 years

- *Pressure test*
- *Internal inspection by opening the unit*
- *Visual check of shell chamber and plate pack*

Local requirements for pressure vessel inspections should also be followed. The inspection periods will be re-evaluated by the inspector after every inspection according to the findings, and shortened if necessary.

5 Cleaning the heat exchanger

5.1 General

The rules and requirements for cleaning a heat exchanger vary from type to type. If there is a risk of fouling, the unit's performance should be monitored by measuring temperature and pressure loss. When losses are greater than permitted, the heat exchanger should be cleaned.

5.2 Recommendations for cleaning

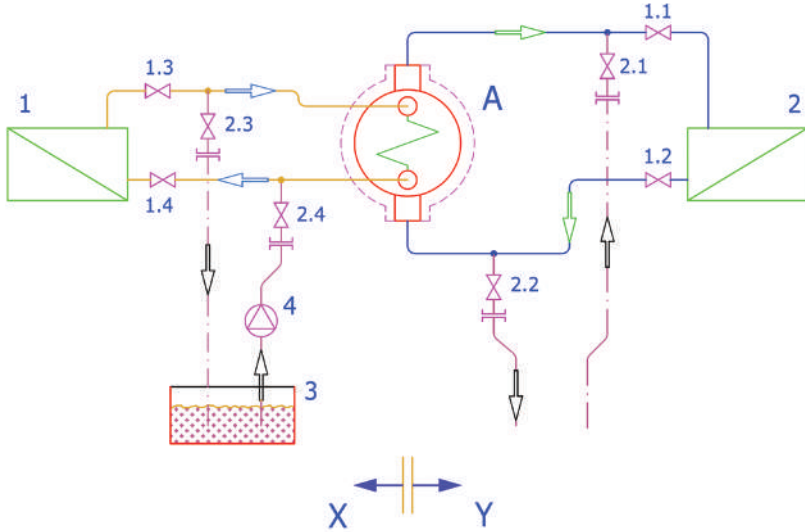

X = cleaning with chemicals

Y = cleaning with backwards flow

A = Vahterus heat exchanger

1 – 2 = heat or cold users or suppliers

1.1 – 1.4 = system shut-off valves

3 = circulating tank

2.1 – 2.4 = shut-off valves for cleaning

4 = pump for chemicals

Fig. 3 Cleaning methods

5.2.1 Backwards flow

In most cases loose materials such as organic compounds gathered on the surface of the plates can be removed by inverting the flow or through back flow washing with warm water or a cleaning medium. Warm water or cleaning medium is flushed at high speed on the primary and/or secondary side in the opposite direction to that of the normal operation (approx. 2–3 times the normal velocity). The valves in the connection pipes must be closed and the drain valves mounted on the pipelines opened. The dirty medium must be discharged and disposed of in accordance with local requirements.

Description of the backwards flow system:

- Close valves 1.1 and 1.2. The temperature of the heat exchanger must be between 10°C and 30°C.
- Drain off the liquid from the side to be cleaned by opening valve 2.2.
- Connect a hose to valve 2.1.
- Water should flow through the heat exchanger for 10–15 minutes.
- Check that organic compounds and dirt are removed.
- Stop the water flow, close valve 2.1.
- Fill the heat exchanger with system liquid in accordance with the start-up procedure detailed above. Close valve 2.2.

If the surface remains dirty, a specific detergent should be used.

5.2.2 Chemical cleaning

A chemical cleaning company experienced in cleaning of plate heat exchangers is recommended.

The cleaning process should involve the use of common cleaning agent brands, which normally contain additives that make for more effective cleaning and prevent corrosion. In order to achieve a good result, the cleaning agent should be chosen based on the dirt and impurities in the process and/or heat exchanger.

The use of an unsuitable cleaning agent may result in worsening the impurity problem.

NB

- Before cleaning the heat exchanger with chemicals, check the resistance of all materials to that chemical.
- After chemical treatment, the plates must be rinsed carefully with clean water.
- If, during cleaning on the coolant side, a high temperature occurs in the heat exchanger, ensure that the pressure on the refrigerant side does not exceed the design pressure of the heat exchanger or the equipment connected to it.
- Before cleaning, remove the refrigerant, and ensure that the refrigerant side is not trapped.

Example of a procedure for cleaning the secondary side with chemicals:

1. Close the valves 1.3 and 1.4. The temperature of the heat exchanger should be between 10°C and 30°C.
2. Connect the hoses of the chemical cleaning system to the valves 2.3 and 2.4.

3. Fill the tank with the chemical solution.
4. Switch on the pump (4) and let it run for 30–40 minutes. During cleaning, intermittently check the concentration and activity of the chemicals on the inlet and outlet side of the heat exchanger. Stop cleaning when there is no longer any change.
5. If dirt has been removed, drain the chemicals from the heat exchanger and the tank, and neutralise the applied chemicals.
6. Wash the plate surface with clean water using back flow.
7. Put the heat exchanger back into normal operation, as described in section 4.

It may be necessary to clean the surface with chemicals more than once.

Handle chemicals and dirt in accordance with safety, environmental, governmental regulations and laws.

WARNING!

Before cleaning, check that the solution is suitable for the flow director material identified on the heat exchanger's Technical Data sheet.

5.2.3 Mechanical cleaning

It is possible to clean openable and EGE models mechanically with a high pressure water jet using hot or cold water. Contact Vahterus for further information.

WARNING!

The high pressure water jet may compress the dirt and impurities into the plate gaps and block the flow passages.

5.2.4 Analysis after cleaning

Analyse if pollution could be avoided by:

- Installing strainers
- Decreasing temperatures (installing desuperheater)
- Increasing system pressure
- Refreshing the medium more frequently, or at shorter intervals
- Adjusting the concentration of the medium
- Increasing the flow between the plates
- Changing the capacity control to a system with constant flow.

5.3 Openable model

The plate pack in openable heat exchangers can be taken out of the shell and cleaned using a high pressure cleaner. When removing it, follow these instructions in order to avoid damaging the plate pack and flow directors.

WARNING!

Never apply pressure to the plate pack outside the shell. The plate pack's support structures are not designed to withstand forces resulting from pressure exerted on it, which may cause an accident.

5.3.1 Preparations

It is recommended that the unit should be moved to a location that is spacious enough to carry out any required service or maintenance. Drain the exchanger on both the plate and shell sides and open all the pipe connections before moving the unit. If the exchanger cannot be moved, only open the connection pipes on the plate side and ensure that there is enough room in front of it to remove the plate pack (the minimum space needed is the entire length of the exchanger).

When removing the plate pack from the shell, measure the pack length from the gasket surface to the end of the pack, and the shell length from the gasket surface to the end plate. The plate pack must be supported by the end plate when installed in the shell. If the plate pack is replaced, measure the shell to ensure the fit of the new plate pack. See section 9.2.

5.3.2 Opening the exchanger and removing the plate pack

Option 1 (recommended)

Move the unit to a more spacious area and turn it so that the end plate connections are facing upwards (plate pack vertical).

Remove some of the bolts from the cover plate and install guide bars (4-6) in the bolt

VAHTERUS

holes before removing the remainder of the bolts. Remember to mark the position of the cover plate relative to the shell to ensure that the plate pack is put back in the same position.

The plate pack is fixed to the cover plate. Pull the cover plate carefully out from the shell using the lifting lugs and try to protect the flow directors.

NB

Ensure that the exchanger is supported properly and that it remains stable and upright while service and maintenance are being carried out.

Fig. 4. Vertical overhauling of the plate pack (option 1)

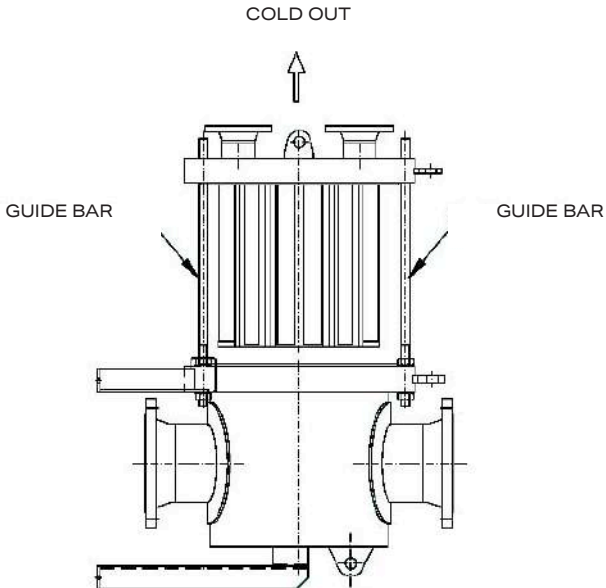

Option 2

When pulling the plate pack out, keep it horizontal, if necessary by using lifting straps. Place the straps in the lifting lugs on the blind flange. When the plate pack is almost entirely out of the shell, place two wooden blocks under the plate pack to protect the flow directors. Place the lifting straps in such a way that they support the plate pack, as in Figure 5.

Fig. 5. Horizontal overhauling of the plate pack

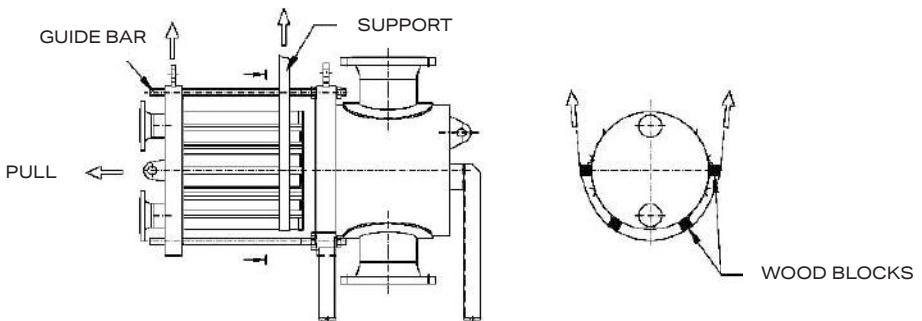

5.3.3 Mounting the plate pack

Before reinstalling the plate pack, the flow directors must be checked, and if necessary, corrected. If the flow director rubbers are damaged and need replacing, please contact Vahterus.

Change the gasket between the cover plate and flange; details of the gasket can be found on the Technical Data sheet.

VAHTERUS

Use the guide bars to ensure that the plate pack is repositioned successfully and safely. Check the position of the plate pack relative to the shell.

Lubricate the flow director rubbers, with vegetable oil, for example, to facilitate repositioning.

When the plate pack is being mounted in the shell, the position of the flow directors must be checked continuously.

5.3.4 Bolt/nut tightening pattern

When tightening bolts, **never** use an impact tool. It is important to tighten the bolts to the same torque value. Always use a torque wrench or other calibrated tightening tool.

The sequence in which the bolts are tightened has a substantial bearing upon the distribution of the pressure on the gasket. Improper bolting may move the flange out of alignment. A gasket will usually allow for a small amount of distortion of this kind. Always tighten the bolts in a cross bolt tightening pattern. See the drawing, where the sequence is numbered.

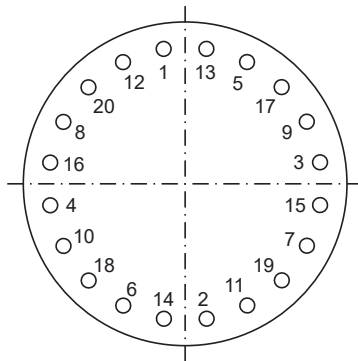

Always screw in the nut or bolt by hand. This ensures that the thread remains in satisfactory condition (if the nut will not screw in by hand, check the thread, replace damaged parts and start again).

Tighten the connections using a minimum of 5 revolutions, following the sequence. The following procedure is recommended:

Revolution 1 – Start the bolt tightening by hand following the sequence, after which all of them should be evenly tightened by hand.

Revolution 2 – Using a torque wrench, tighten the bolts, following the sequence. Use a maximum of 30% of the eventual tightening torque. Check the position of the gasket between the cover plate and flange.

Revolution 3 – Tighten using 60% of the eventual torque, following the sequence.

Revolution 4 – Tighten to full torque in a clockwise direction.

The tightening torque on lubricated bolts is stated in the GA drawing supplied with the exchanger.

6 Expandable Plate Pack

An openable pack model may be expandable to facilitate the cleaning of the pack, for which separate instructions are available. Contact Vahterus for further information.

7 Spare Parts / Special Tools

Openable heat exchanger:

- Flow directors
- Plate pack
- Gasket between the cover plate and flange
- Guide bars

These parts can be supplied when the exchanger serial number is provided.

8 Packing and Storage

The equipment is supplied checked and packed on the manufacturing site. After delivery, please check that the packaging and equipment have not been damaged during transportation. Check that the gasket remains on the sealing face between the cover plate and flange. If any damage is found please contact Vahterus, as well as the transport company responsible for the shipment.

Each heat exchanger leaves the factory in a sturdy wooden box. The boxes are made from Finnish pine harvested in a sustainable forest.

The wood is free from quarantine pests and other injurious pests. The wood is ISPM15 compliant and supplied with the following saw-mill stamp.



Fig. 6. Standard packing

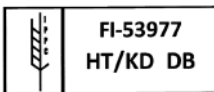

Fig. 7. IPPC-stamp for wooden boxes. The packing materials are recyclable into energy or other uses.

VAHTERUS

Heat exchangers must be stored indoors and covered for greater protection against dust, in a location providing temperatures from +1°C to +40°C and relative humidity up to 90%.

Ensure that no liquids, dust, etc. come into contact with the equipment during storage.

The equipment must be stored in an area free from construction activities and vehicle transit that could cause accidental damage.

The equipment must not come into contact with the ground.

Adequate free space must be available around equipment to guarantee periodic inspections and free movement.

The maximum storage period is 12 months.

Long term storage period (5 years) is possible, if the equipment is ordered with nitrogen filling.

Upon the expiry of assigned parameters (assigned storage period, assigned service life) operation of the equipment is stopped, equipment is inspected, repaired (if necessary) and new assigned parameters are established (assigned service life and/or assigned storage period). If the repair is not possible (or not reasonable) the equipment is disposed of.

9 Troubleshooting

If the exchanger is not working properly after start-up, please check the following before contacting your Vahterus representative:

Problem	Cause	Checks	Action	NB
Poor performance	Exchanger/ connections connected incorrectly	Check flow directions of connections. Do they comply with the design/ drawing?	Change the piping connections. Change direction of flow	
	Incorrect pressure	Check pressure and temperatures on both sides	Correct or adjust valves	Contact the manufacturer and provide the following values: pressures, pressure differences, temperatures and flow rates

VAHTERUS

Problem	Cause	Checks	Action	NB
	Pressure difference	Measure flow rates and pressure difference		
	Temperature	Compare these values to the PSHE's thermo-technical data sheet		
	Liquid flow	Check pump operation	Change pump	
Very poor performance and low pressure difference	Flow director damaged by pressure shock or unsuitable process fluid	Check the information on the name plate: are the temperature, and liquids correct? Check the process data if it is available	Contact the manufacturer	

Problem	Cause	Checks	Action	NB
External leakage between cover plate and flange (openable model)	Leaking gasket	Look for leak	Tighten bolts. If retightening does not stop the leak, remove cover plate and change gasket	The Technical Data sheet contains details of the gasket. See tightening torque in section 5.3.4
Internal leak (fluid mix)	Plate cracked due to water hammer or thermal shock	Check that plate side liquid is visible on shell side (leaking fluid will be visible on the outlet pipe)	Contact Vahterus	
	Hole in plate due to corrosion	Close plate or shell side valves and use a metre to see if the pressure is falling		

VAHTERUS

Problem	Cause	Checks	Action	NB!
	Pressure shock	Check the process data, if available	Contact the manufacturer	
	Mechanical wear	Pressurise shell and find leak. Localise leak e.g. with colouring agent	Contact the manufacturer	
Very poor performance and very high pressure difference	Shell or plate side channels clogged with accumulation of debris or scale	Carefully measure pressure loss on both sides to find the cause of the problem.	Clean exchanger according to instructions (section 5)	Run scheduled maintenance/ check work plan
	Filter clogged	Open filter and check its condition	Clean/ change filter	

Problem	Cause	Checks	Action	NB!
	Issue with valve and process controls	Check operation of valves	Open, adjust or change valves	
Gradual decline in heat transfer performance	Slow build-up of impurities on plate surfaces on the plate or shell side	Remove the plate pack (openable model) and examine the heat transfer surfaces. Welded models can be checked using an endoscope. If the shell side is clean, fouling of the plate side is responsible for the retardation of heat transfer	Clean exchanger according to instructions (section 5). Replace gasket and plate pack (openable model)	Run scheduled maintenance/ check work plan

9.1 Complaints report

If you wish to complain about a Vahterus product, ask for a notification of defect report at: sales@vahterus.com. Please include as many details as possible, and especially the following:

- General information (including serial number)
- Design and operation
- Type of problem and observations
- Status of process

When you have completed the report, please contact your Vahterus representative.

9.2 Measures for replacements

If there is a need to replace a plate pack for an openable heat exchanger, take the measurements at four different points inside the shell – see diagram below.

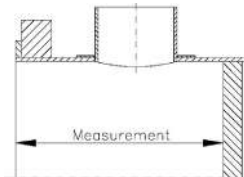

9.3 Information about the repair

The repair must be performed by a qualified technician under the full responsibility of

the user, according to rules that are in force in the country of the user, and original design drawings. If necessary, please contact Vahterus for more information.

9.4 Criteria of limiting conditions for the equipment

- Mechanical wear (abrasion), scratches, corrosion damage that exceeds the corrosion allowance for the wall thickness provided in the strength calculation.
- Mechanical damage to the plates that causes media to mix.
- Dents, ovality, wear of equipment (or elements) over permissible values.
- Cracks of all kinds.
- Defects in welds exceeding acceptable values, including single slags and gas inclusions.
- Corrosion and cracking of the metal in the zone of the welds and close to the corrosion spots.
- Damage to the gaskets of flange connections or weakening of bolting.

10 Recycling

The metals used in our heat exchangers are recyclable, for example to make steel. The rubber from the flow directors is not recyclable and must be disposed of according to local waste disposal regulations.

VAHTERUS

Safety

Before a Vahterus heat exchanger can be put into operation, the user must be sure that:

- Sufficient safety valves have been installed and adequate safety measurements have been taken into account.
- The plate pack or plate insert of an openable unit is never pressurised when outside the shell.
- Sufficient measures have been taken to prevent possible corrosion of the pressure vessel, particularly under the insulation.

Vahterus Oy
Pruukintie 7
23600 Kalanti, Finland
+358 2 84 070

Vahterus is certified by Kiwa Inspecta:

ISO 9001

ISO 3834-2

ISO 14001

ISO 45001

vahterus.com



MANUAL DE FUNCIONAMENTO E MANUTENÇÃO

Todos os direitos reservados.
Não é permitida a cópia, reprodução ou publicação sob qualquer forma
deste manual para qualquer fim sem a
autorização da Vahterus Oy.
Plate & Shell e Plate & Ring são marcas registadas da
Vahterus Oy.

C303-3-FI-rev.2 /23.06.2010

1 GERAL	4
1.1 INTRODUÇÃO	4
1.2 PRODUTOS.....	4
1.3 ESTRUTURA.....	5
2 MONTAGEM DO PERMUTADOR DE CALOR.....	6
2.1 ELEVAÇÃO.....	6
2.2 TUBOS	7
2.2.1 GERAL.....	7
2.2.2 APLICAÇÕES DE VAPOR (CONDENSADOR).....	8
2.3 ISOLAMENTO	8
2.4 TESTE DE PRESSÃO.....	9
2.5 SUPORTES DE MONTAGEM	9
3 CONDIÇÕES DE OPERAÇÃO PERMITIDAS	10
3.1 CONCEPÇÃO	10
3.2 FLUIDOS.....	10
3.3 TAXAS DE FLUXO.....	11
4 OPERAÇÃO E INICIALIZAÇÃO	12
4.1 FUNÇÃO DO PERMUTADOR DE CALOR	12
4.1.1 LÍQUIDO – LÍQUIDO.....	13
4.1.2 CONDENSADOR.....	13
4.1.3 DX- EVAPORADOR.....	14
4.1.4 EVAPORADOR INUNDADO	14
4.1.5 SEPARADOR DE GOTAS	14
4.1.6 GERADOR DE VAPOR (KETTLE)	15
4.1.7 PERMUTADOR DE GÁS	15
4.2 INICIAR	15
4.3 DESLIGAR.....	17
5 LIMPAR O PERMUTADOR DE CALOR	18
5.1 GERAL.....	18
5.2 RECOMENDAÇÕES PARA LIMPEZA	18
5.3 MODELO QUE PODE SER ABERTO.....	19
5.3.1 PREPARATIVOS	20
5.3.2 ABERTURA DO PERMUTADOR E REMOÇÃO DO CONJUNTO DE PLACAS.....	20
5.3.3 MONTAGEM DO CONJUNTO DE PLACAS.....	22
5.3.4 PADRÃO DE APERTO DAS PORCAS/PARAFUSOS	22
6 PEÇAS DE SUBSTITUIÇÃO / FERRAMENTAS ESPECIAIS	24
7 RESOLUÇÃO DE PROBLEMAS	25
7.1 RELATÓRIO DE RECLAMAÇÃO	27
7.2 MEDIÇÕES PARA SUBSTITUIÇÃO.....	28

1 GERAL

1.1 INTRODUÇÃO

Este manual é o seu guia geral para a correta instalação, operação e manutenção da Vahterus Plate e do Permutador de Calor Shell (PSHE).

Leia este manual e siga as instruções dadas.

O PSHE é uma placa permutadora de calor totalmente soldada sem quaisquer juntas entre as placas.

A Vahterus não aceita qualquer responsabilidade pelos danos causados por uma incorreta instalação, operação ou manutenção da unidade

1.2 PRODUTOS

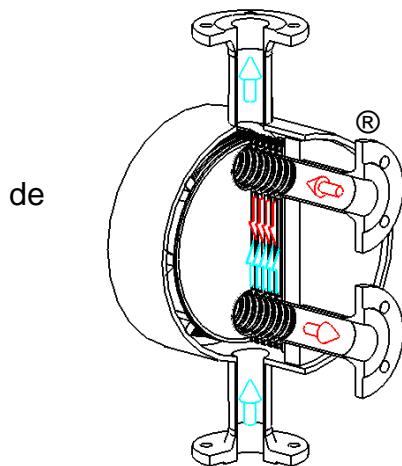

Plate & Shell ®

Modelo totalmente soldado – um conjunto placas circulares soldadas dentro de um recipiente de pressão soldado. As aplicações para este tipo são líquido-líquido, condensador, evaporador e cascata. Este modelo não pode ser aberto. Este permutador de calor pode ser de passagem única ou múltipla. (Consulte o capítulo 4: Fundamentos de permutadores de calor.)

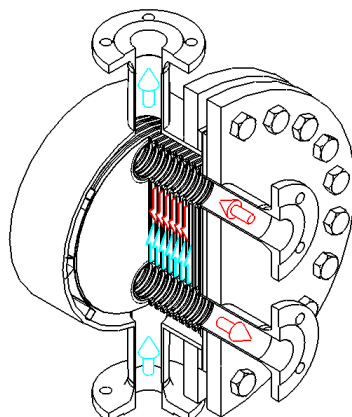

Plate & Shell ®

®
Modelo que pode ser aberto. Conjunto de placas totalmente soldadas dentro de um invólucro que pode ser aberto. O conjunto de placas pode ser retirado do invólucro

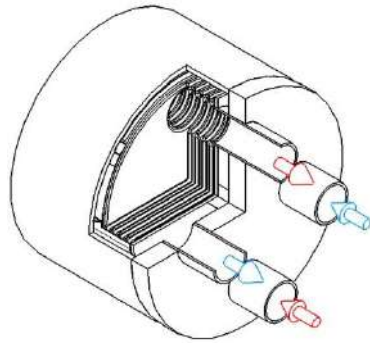

Plate & Shell ®
Compacto

Todas as ligações estão na placa de extremidade. Poder ser de passagem única ou múltipla.

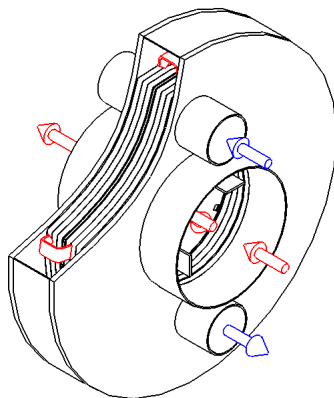

Plate & Ring ®

Um conjunto soldado de placas circulares. Utilizado com aplicações de gás.

1.3 ESTRUTURA

A Vahterus Plate e o Permutador de Calor Shell são concebidos e fabricados de acordo com a legislação referente a equipamentos de pressão.

O código de concepção utilizado é dado na folha de Dados Técnicos da Vahterus. Os códigos geralmente utilizados são:

□□ASME VIII Div.1, com base numa concepção individual para cada um dos permutadores de calor.

□□PED 97/23/EC: a concepção é baseada na homologação. O número de homologação e classificação DEP (Diretiva de Equipamento de Pressão) são mostrados na folha de Dados Técnicos.

2 MONTAGEM DO PERMUTADOR DE CALOR

2.1 ELEVAÇÃO

Deve ser reservado bastante espaço em torno do permutador de calor para a montagem, isolamento e manutenção. Com o modelo que pode ser aberto, deve existir na parte da frente espaço disponível igual ao comprimento total de forma a permitir a remoção do conjunto de placas.

Assegure-se que existe espaço adequado por cima do permutador de forma a que a sua elevação possa ser realizada livremente.

Os permutadores de calor são fornecidos com presilhas de içamento soldadas ou olhais.

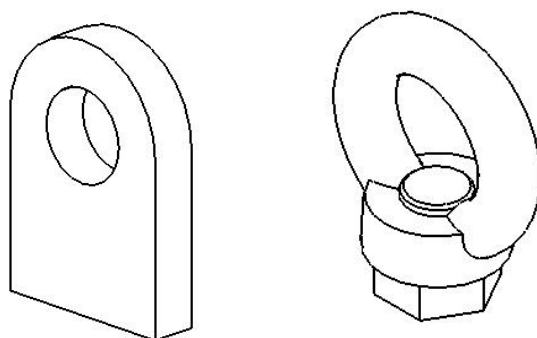

Presilha (olhal) de içamento	Força de elevação (elevação direta)
1T (Soldado)	1.000 kg
3T (Soldado)	3.000 kg
5T (Soldado)	5.000 kg
7T (Soldado)	7.000 kg
18T (Soldado)	18.000 kg
M16 (DIN 582)	700 kg
M20 (DIN 582)	1.200 kg

NOTA

Quando são combinados permutadores de calor com separadores de gotas deve-se ter em conta o peso total do conjunto. É essencial que toda a unidade seja suportada por uma grua ou elevada pelos olhais de içamento até os parafusos de fixação serem apertados.

Se necessário o conjunto pode ter um suporte extra permanente utilizando os olhais de içamento nas estruturas de suporte circundantes.

Não utilize os suportes de montagem ou os bocais para elevar o permutador de calor.

AVISO



Não solde nada ao permutador de calor (incluindo o invólucro, placas das extremidades e as laterais dos canos) sem a autorização do fabricante, uma vez que tal ato pode danificar as estruturas internas do permutador de calor.

2.2 TUBOS

2.2.1 GERAL

Instale a unidade de forma que os tubos e o permutador de calor possam ser facilmente drenados.

O permutador de calor não é normalmente fornecido com ligações de drenagem e ventilação separadas. Se o processo do cliente requer que estas sejam separadas, devem ser instaladas na tubagem o mais perto possível do permutador de calor, ou se precisarem ser instaladas no permutador, devem ser especificadas em separado quando da encomenda do permutador.

Verifique o seguinte:

1. As tubagens a serem montadas no permutador devem ser lavadas antes de serem ligadas à unidade.
2. Todas as ligações estão marcadas e devem ser executadas de acordo com o desenho da disposição geral.
3. O sistema de tubagem deve ser flexível de forma que a expansão térmica não afete os bocais de ligação e para evitar que o permutador de calor esteja sujeito a vibrações.
4. Todas as ligações dos tubos do permutador de calor devem estar equipadas com válvulas de corte. É recomendado o uso de válvulas com abertura lenta. Deve ser possível aumentar as taxas de fluxo gradualmente e reduzi-las também gradualmente quando o sistema está para ser desligado.
5. Se existirem sólidos nos fluidos processados, é recomendado a utilização de filtros. Qualquer informação adicional pode ser obtida junto ao departamento de vendas da Vahterus.
6. A tubagem deve ser equipada com uma válvula de descarga de forma a prevenir o excesso não intencional da pressão acima dos valores da concepção.
7. Se estiverem a ser combinadas múltiplas unidade em paralelo, deve-se assegurar que o fluxo seja distribuído uniformemente por todos os permutadores.

Modelo que pode ser aberto

As ligações entre o conjunto de placas no modelo que pode ser aberto e os tubos devem ser realizadas com flange ou roscadas.

2.2.2 APLICAÇÕES DE VAPOR (CONDENSADOR)

As tubagens devem ser concebidas tendo em conta um bom fluxo de vapor.

Em aplicações com vapor a unidade é colocada horizontalmente para prevenir que a condensação permaneça na superfície das placas.

É recomendado, onde necessário, a instalação de um purgador de vapor (dreno) na frente e na parte posterior do permutador de calor e um separador de humidade na parte da frente. Os separadores na frente do permutador são instalados antes da válvula. Isto vai prevenir o acúmulo de condensação após a válvula.

Quando o vapor de água está do lado do invólucro, o permutador de calor é fornecido com um batente, que é soldado na ligação HOT IN para prevenir o impacto da água. No entanto, o cliente deve também tentar evitar por outros meios o impacto da água no permutador de calor.

AVISO



Quando a válvula está fechada, a condensação pode se acumular na tubagem se não for dada atenção ao escoamento. Quando a válvula está aberta, a água acumulada passa a alta velocidade para o permutador de calor, possivelmente resultando em danos mecânicos.

NOTA

Se o permutador estiver em operação num vácuo parcial ou haja a possibilidade, em alguma circunstância, da pressão do lado do vapor causar uma baixa na pressão no lado da condensação, deve ser considerado o uso de uma bomba de condensação.

Quanto for usado um regulador de condensação, a temperatura de condensação no lado quente não pode ser superior à temperatura de evaporação do lado frio, por exemplo, se existir água no lado frio, a pressão do vapor deve ser menor que a pressão da água, para prevenir que a água ferva.

2.3 ISOLAMENTO

Se a temperatura no lado do invólucro for inferior a $-10\text{ }^{\circ}\text{C}$ ou acima de $65\text{ }^{\circ}\text{C}$, é recomendado a aplicação de isolamento para evitar queimaduras.

2.4 TESTE DE PRESSÃO

Todas as unidade PSHE sofrem testes de pressão da seguinte forma:

- a) todos os conjuntos de placas – teste de fugas (teste de pressão pneumática debaixo de água)
- b) unidade em si – teste de pressão (teste de pressão hidrostático)

Se houver necessidade de efetuar um teste de pressão antes da utilização do permutador de calor, a pressão de teste é dada na folha de Dados Técnicos e na chapa de identificação da unidade.

NOTA

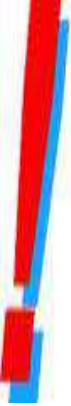

O teste de pressão no conjunto das placas no permutador de calor que pode ser aberto deve ser sempre realizado com o conjunto das placas posicionado no invólucro e os parafusos da placa de cobertura devidamente apertados, de acordo com as instruções deste manual.

Quando estiver a ser efetuado um teste de fuga pneumático ou de pressão, certifique-se que existem todas as condições de segurança, uma vez que pode ocorrer uma descarga de pressão similar a uma explosão no caso do permutador ou equipamento de teste estar defeituoso.

NUNCA APLIQUE PRESSÃO AO CONJUNTO DAS PLACAS FORA DO INVÓLUCRO.

2.5 SUPORTES DE MONTAGEM

Os suportes de montagem padrão da Vahterus foram concebidos para suportar somente o peso do permutador de calor. A concepção não permite requerimentos específicos, tais como a tensão e esforço causado pelo tubo, cargas de vento ou sismos.

3 CONDIÇÕES DE OPERAÇÃO PERMITIDAS

3.1 CONCEPÇÃO

As pressões e temperaturas de concepção são registradas na placa de identificação e na folha de Dados Técnicos.

Nunca exceda as pressões e temperaturas de concepção. As temperaturas ambientais não podem ser mais elevadas ou inferiores à gama de temperaturas especificadas.

A carga ambiental, carga nas ligações causadas pela tubagem, carga de vento e sismos não são tidos em conta nos cálculos de forma durante a concepção, a não ser que estejam mencionados separadamente.

A tubagem no permutador de calor e os suportes de montagem não devem ser sobrecarregados por forças externas, a não ser que esteja mencionado separadamente nos cálculos de força.

A tolerância de corrosão está indicada nos cálculos de força: para aço carbono é de pelo menos 1 mm. Qualquer requerimento de tolerância de corrosão superior deve ser mencionado quando da encomenda do permutador de calor.

Fadiga: 1.000 ciclos de pressão completos permitidos sem cálculos separados. Se este número for excedido, o cliente deve testar o permutador de calor (testes de pressão e possivelmente testes NDE) com referência às leis locais.

Risco de possível fogo externo: o cliente deve aconselhar o fabricante.

Os aparelhos de segurança devem ser especificados/concebidos e adquiridos pelo cliente, uma vez que não são fornecidos pela Vahterus Oy.

3.2 FLUIDOS

Os materiais estruturais são seleccionados com base na informação (médias, temperaturas, fluxos) fornecidos pelo cliente. Pode-se também contactar a Vahterus para obter as opções referentes a materiais e direccionadores de fluxos.

Se o permutador de fluxo for utilizado em condições que difiram daquelas para as quais foi concebido (folha de Dados de Engenharia Térmica), é necessário verificar a sua capacidade para funcionar nas condições atuais. Por exemplo, se a viscosidade do fluido variar de acordo com as condições e diferir da informação na folha de Dados Técnicos e puder resultar numa diferença na pressão de mais de 200 kPa entre o permutador e os conectores de entrada e saída, a Vahterus deve ser contactada para reavaliar as condições de carga.

Quando o cliente aprovar os materiais do permutador de calor, este tem que assegurar que os mesmos vão suportar as condições às quais vão estar sujeitos durante o seu processo. Aço resistente a ácido é ainda susceptível de ser afetado por forma de corrosão, por exemplo, corrosão intergranular, corrosão por ferrugem, corrosão por tensão e corrosão biológica. O conteúdo de cloreto da água pode causar corrosão nos materiais AISI 316L/ .4404 das superfícies num curto espaço de tempo. Quando a água está a ferver, em particular, provoca precipitação com cloreto e isto pode levar a corrosão em concentrações muito baixas. Outros fatores que podem causar risco de corrosão são o PH, a taxa de fluxo dos líquidos, sujeira na placa, impurezas, etc., cujos efeitos devem ser levados em conta para cada processo individual. Se existir um risco de corrosão, devem ser considerados materiais com uma maior durabilidade tais como AISI 904L, SMO 254, Duplex ou titânio.



NOTA

Para instruções especiais sobre a qualidade da água em geradores de vapor, contate o departamento de vendas da Vahterus.

Restrições quando do uso de placa de permutação em material DC01 (aço carbono):

- Aplica-se às seguintes substâncias: NH_3 , CO_2 , óleos e compostos CaCl_2 .
- Gama de temperatura ente -50 e $+100^\circ\text{C}$
- Pressão máxima permitida por concepção de 40 barg, para pressões mais altas contate o fabricante.
- Os compostos CaCl_2 podem ser somente usados num sistema fechado no qual a temperatura não seja superior a 20°C em qualquer circunstância. Todo o ar deve ser expelido do sistema.
- O conteúdo de água em NH_3 , CO_2 ou óleos deve ser o menor possível (praticamente zero).

O cliente deve informar o fabricante se forem usados fluidos instáveis no processo.

3.3 TAXAS DE FLUXO

As taxas de fluxo devem ser mantidas o mais perto possível dos valores de concepção.

Taxas de fluxo inferiores podem causar alterações inesperadas no permutador de calor e sujar as superfícies da placa.

Se deseja utilizar o permutador de calor essencialmente com maiores taxas de fluxo, a aptidão do permutador deve ser verificada com o fabricante.

4 OPERAÇÃO E INICIALIZAÇÃO

4.1 FUNÇÃO DO PERMUTADOR DE CALOR

O propósito do permutador de calor é o de transferir calor de um fluxo ou fluido para outro através de uma placa ondulada de transferencia de calor.

Este é construído de tal forma que o fluxo alterna através do conjunto de placas. O fluxo pode ser controlado como contracorrente, concorrente ou fluxo cruzado.

Estrutura do Vahterus Plate e permutador de calor Shell[®] :

O Plate e permutador de calor Shell[®] consistem em placas circulares soldadas num conjunto, que é depois montado num recipiente de pressão.

O fluxo no lado da placa passa pelas ligações nas placas de extremidade através do conjunto de placas.

O fluxo no lado do invólucro passa pelas ligações do mesmo através do conjunto de placas utilizando um direcionador de fluxo.

A construção poder ser totalmente fechado e soldado ou com possibilidade de abertura. O tipo com possibilidade de abertura tem uma placa de cobertura removível de forma que o conjunto das placas possa ser removido, para limpeza, por exemplo.

Estas são as várias aplicações de um permutador PSHE:

4.1.1 LÍQUIDO – LÍQUIDO

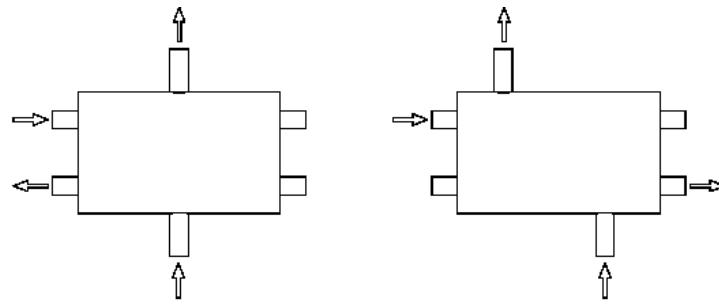

1 - passagem

1. 3 - passagem

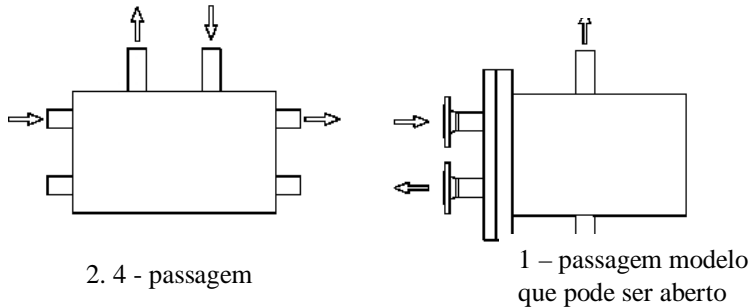

2. 4 - passagem

1 - passagem modelo
que pode ser aberto

Em aplicações líquido-líquido, os lados quente e frio podem ser montados em qualquer dos lados do permutador. De uma forma geral, o lado quente pode ser no lado da placa e o lado frio no lado do invólucro. Os lados quente e frio estão claramente marcados nos desenhos e permutadores de calor.

4.1.2 CONDENSADOR

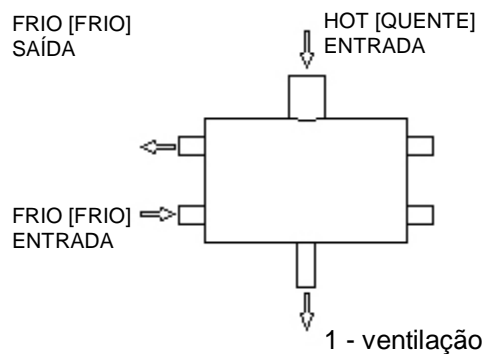

Em aplicações de condensação, o vapor é no lado do invólucro, com o frio no lado da placa. O fluxo (vapor) do lado do invólucro entra no permutador no topo do invólucro e o fluxo condensado sai pela parte de baixo. O fluxo do lado da placa é contracorrente: o permutador funciona sob o princípio contracorrente.

Também são possíveis configurações com vapor no lado frio/lado da placa e concepções de condensador de ventilação.

4.1.3 DX- EVAPORADOR

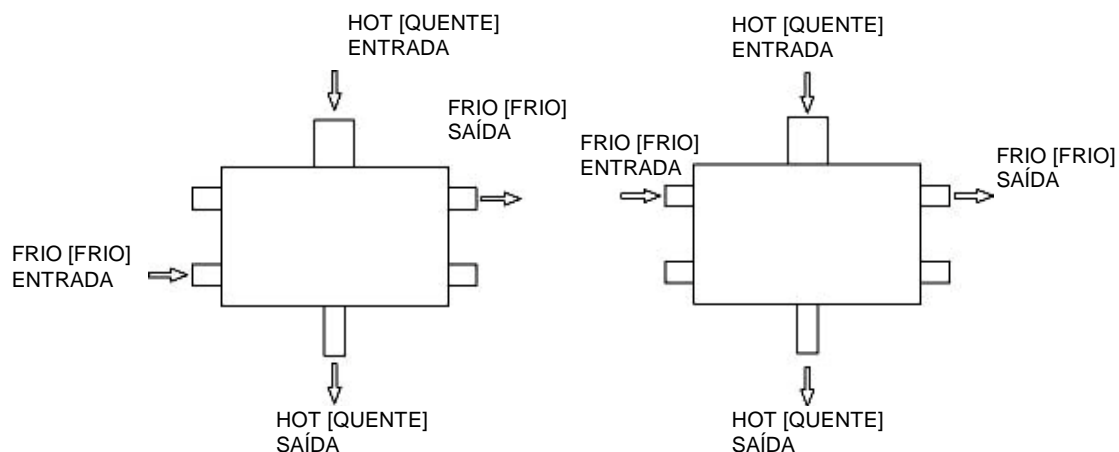

1. 3 - passagem

2, 4 – passagem / lado do conjunto
1 – passagem / lado do invólucro

A vaporização ocorre sempre no lado da placa e o arrefecimento no lado do invólucro.

4.1.4 EVAPORADOR INUNDADO

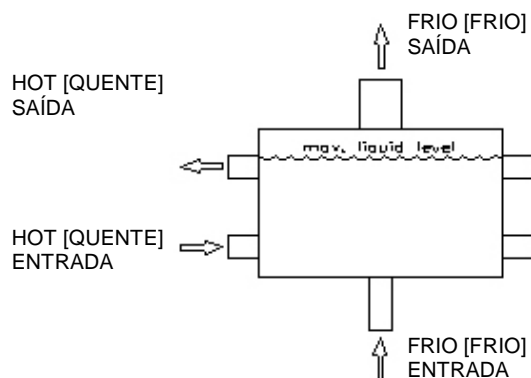

1 - passagem
excêntrico

Evaporação normalmente ocorre no lado do invólucro. No entanto, com aplicações especiais, a evaporação pode ocorrer do lado do conjunto de placas.

4.1.5 SEPARADOR DE GOTAS

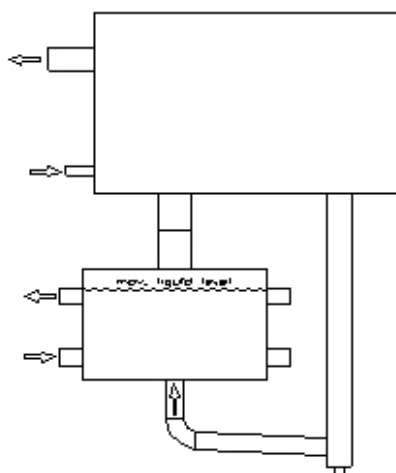

O sistema de permuta de calor é o mesmo do que em 4.1.4, com a adição de um separador de gotas e tubo de recirculação.

No permutador de calor combinado o separador de gotas é integrado com o invólucro do permutador

4.1.6 GERADOR DE VAPOR (KETTLE)

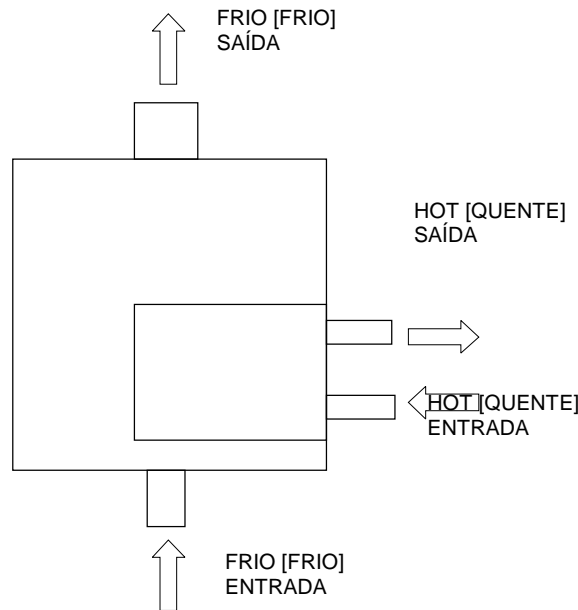

Posição do conjunto de placas num invólucro grande. Aplicação de gerador de vapor.

4.1.7 PERMUTADOR DE GÁS

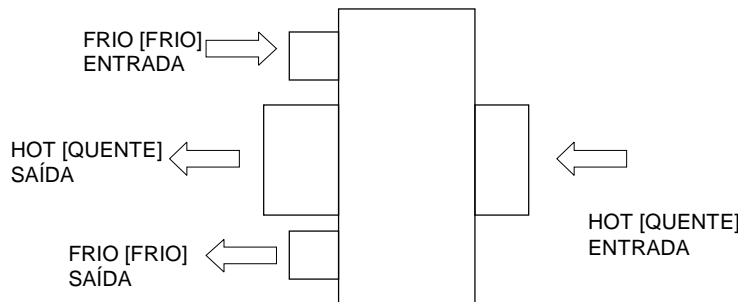

Para gases de aquecimento ou arrefecimento

4.2 INICIAR

Verifique o seguinte antes de iniciar:

- Que as ligações dos tubos estão em conformidade com os desenhos e que estão devidamente apertadas/suportadas.
- Que as válvulas de escoamento estão fechadas.
- Que quaisquer aparelhos de segurança estão devidamente conectados.
- Que não existem fatores de risco nos tubos que possam causar choques de pressão (impacto de água) ou mudanças súbitas na pressão.

Primeiro iniciar o fluxo no lado frio, e depois iniciar e vá aumentando gradualmente o fluxo no lado quente.

Se, no entanto, o líquido que estiver a ser usado tiver alta viscosidade, iniciar o lado quente primeiro.

Com o evaporador inundado, iniciar sempre primeiro o lado quente.

Se o permutador de calor estiver a ser iniciado em condições frias (abaixo dos 0°C), é recomendado que limite a taxa à qual a temperatura aumenta até 100°C por hora.

A pressão pode ser diretamente aumentada para a pressão de operação.

Consulte também a secção 3.2.

Para dar início ao processo de permuta de calor, siga os passos a-f, iniciando primeiro pelo lado frio. Depois repita para o lado quente.

- a) Feche a válvula de corte de entrada.
- b) Abra a válvula de corte de saída.
- c) Abra a válvula de ventilação, se o permutador estiver equipado com uma, se não faça a ventilação na tubagem usando a válvula que estiver mais perto do permutador de calor.
- d) Inicie a bomba.
- e) Gradual e lentamente abra a válvula de entrada de acordo com as instruções.
- f) Feche a válvula de ventilação quando todo o ar tiver sido removido do sistema.

Se o permutador de calor estiver funcionando devidamente pode ser utilizado de uma forma contínua.

Modelo que pode ser aberto

Quando o modelo que pode ser aberto estiver a ser inicializado, verifique sempre também os parafusos e aperte-os se necessário.

4.3 DESLIGAR

Se tiver que parar o processo de permuta de calor, siga os passos a-d abaixo, começando primeiro no lado quente. Depois repita para o lado frio.

- a) Lentamente feche as válvulas de entrada.
- b) Desligue as bombas.
- c) Feche as válvulas de saída.
- d) Drene e faça a ventilação do permutador de calor.

Gradualmente diminua o fluxo no lado quente até que pare completamente. Depois feche o lado frio.



NOTA

As válvulas devem estar definidas para uma abertura gradual. Uma abertura ou fechamento súbito das válvulas vai submeter o permutador a um choque térmico e pode causar fadiga no material.

Em aplicações de vapor, nunca deixe a válvula de vapor ligada quando o lado do líquido estiver desligado. DESLIGUE o vapor primeiro e LIGUE no fim.

5 LIMPAR O PERMUTADOR DE CALOR

5.1 GERAL

As regras e requisitos para limpar o permutador de vapor variam de tipo para tipo. Se existir o risco de entupimento, o desempenho da unidade deve ser monitorado medindo a temperatura e perda de pressão. Quando as perdas forem maiores que o permitido, o permutador de calor deve ser limpo.

5.2 RECOMENDAÇÕES PARA LIMPEZA

Retrolavagem:

A sujeira que puder se acumular na superfície das placas pode, na maioria dos casos, ser removida lavando-se o sistema com água quente. Água limpa é bombeada a alta velocidade contra a direção normal do fluxo (em ambos ou apenas num dos lados). As válvulas nos tubos são fechadas e as válvulas para a lavagem são abertas. Toda a água suja deve ser tratada de acordo com as regras universais e legislação local.

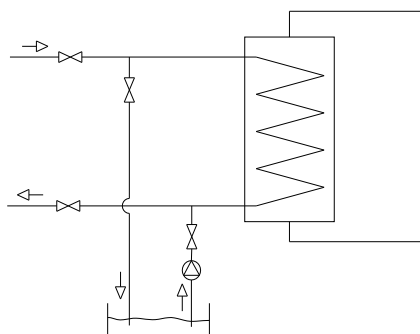

Limpeza química:

A limpeza química deve estar a cargo de uma empresa com conhecimentos e experiência na limpeza de permutadores de calor. O processo de limpeza deve envolver a utilização de agentes de limpeza comuns, que normalmente contêm aditivos que tornam a limpeza mais eficiente e previnem a corrosão.

As seguintes soluções alcalinas e ácidas podem também ser usadas para a limpeza química de permutadores de calor: soda, solução alcalina a 2% (NaOH) ou 0.5 % ácido nítrico ou 5% ácido sulfamídico (NÃO ácido sulfúrico), que pode ser usado até 60°C. Pode também ser usado ácido fosfórico em concentrações de 5%.

Causa do entupimento	Agentes de limpeza recomendados
Sulfato de cálcio, silicatos	Ácido cítrico, nítrico, fosfórico ou sulfamídico
Carbonato de cálcio	Ácido nítrico a 10%
Alumina, óxidos de metais, sedimento/lama	Ácido cítrico, nítrico, fosfórico ou sulfamídico (solução a 5%)
Perceves, mexilhão, algas, lascas de madeira	Retrolavagem Limpeza ultra-sônica
Crescimento biológico	Carbonato de sódio ou hidróxido de sódio

AVISO

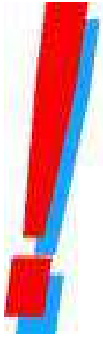

Se o material do invólucro for aço carbono, não utilize ácido nítrico para limpeza da parte do invólucro, e reduza a concentração de ácido sulfamídico para 2%.

O ácido sulfamídico hidrolisa com a temperatura e o passar do tempo, assim utilize sempre solução recém preparada.

Após o tratamento com soda, ácido ou detergente, o permutador deve ser muito bem enxaguado para remover estas substâncias.

Nunca utilize ácido clorídrico para limpar permutadores de calor, mesmo em baixas concentrações

Nunca utilize ácidos fosfórico ou sulfamídico para limpar permutadores de calor de titânio, mesmo em baixas concentrações.



Antes de limpar, verifique que a solução é adequada para o material do direcionador de fluxo. O tipo de material está indicado na folha de dados do permutador de calor.

5.3 MODELO QUE PODE SER ABERTO

O conjunto de placas no modelo de permutadores de calor que pode ser aberto pode ser retirado do invólucro e limpo com uma máquina de lavar de alta pressão. Quando remover o conjunto das placas siga estas instruções de forma a evitar danificar o conjunto de placas e direcionadores de fluxo.



AVISO

NUNCA APLIQUE PRESSÃO AO CONJUNTO DAS PLACAS FORA DO INVÓLUCRO. AS ESTRUTURAS DE SUPORTE DO CONJUNTO DE PLACAS NÃO ESTÃO CONCEBIDAS PARA SUPORTAR FORÇAS RESULTANTES DA PRESSÃO EXERCIDA SOBRE ELAS, POIS A APLICAÇÃO DE PRESSÃO PODE CAUSAR UM ACIDENTE.

5.3.1 PREPARATIVOS

È recomendado que mova a unidade para um local com espaço suficiente de forma a executar qualquer trabalho de assistência ou manutenção necessário. Drene o permutador em ambos os lados da placa e do invólucro e liberte as ligações dos tubos antes de mover a unidade. Se o permutador não puder ser movido, liberte somente os tubos de conexão no lado da placa e assegure-se que existe espaço suficiente na frente para remover o conjunto de placas (o espaço mínimo necessário é o comprimento total do permutador).

5.3.2 ABERTURA DO PERMUTADOR E REMOÇÃO DO CONJUNTO DE PLACAS

Opção (recomendada)

Mova a unidade para uma área espaçosa e a posicione de forma que as ligações da placa de extremidade estejam viradas para cima (conjunto de placas na vertical).

Remova alguns dos parafusos da placa de cobertura e instale barras guia (4-6) nos furos dos parafusos antes de remover os restantes. Não se esqueça de marcar a posição da placa de cobertura em relação ao invólucro para assegurar que o conjunto de placas será colocado na mesma posição!!

O conjunto de placas é apertado à placa de cobertura. Puxe a placa de cobertura cuidadosamente para fora do invólucro utilizando os olhais de içamento e tente proteger os direcionadores de fluxo.



Assegure-se que o permutador é devidamente suportado e que se mantém estável e direito enquanto a assistência e manutenção é executada.



Diagrama 1

Opção 2

Quando puxar para fora o conjunto de placas, mantenha-as horizontais, se necessário recorrendo a cintas de içamento. Coloque as cintas nos olhais de içamento do rebordo. Quando o conjunto de placas estiver praticamente todo fora do invólucro, coloque dois blocos de madeira por baixo do conjunto de placas para proteger os direcionadores de fluxo. Coloque as cintas de içamento de tal forma que estas suportem o conjunto de placas, como no diagrama 2.

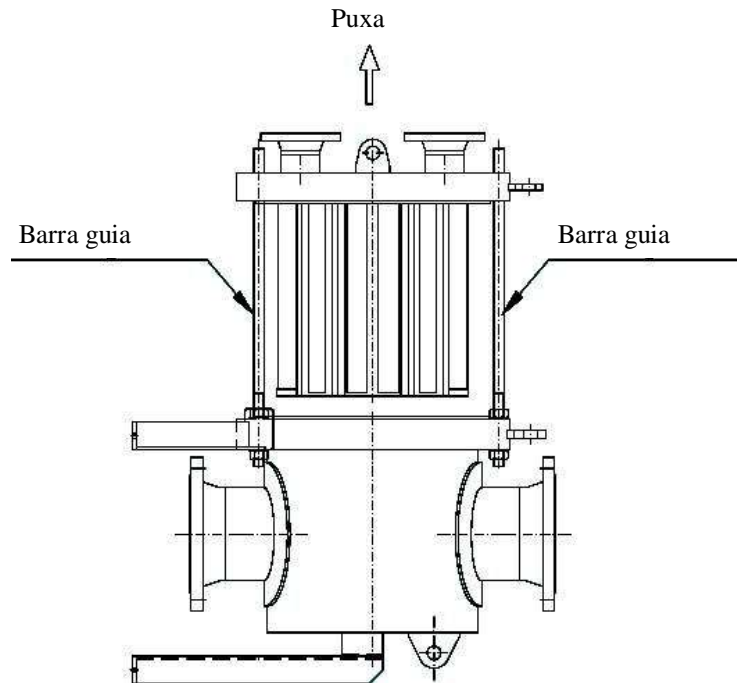

Diagrama 2

5.3.3 MONTAGEM DO CONJUNTO DE PLACAS

Antes de reinstalar o conjunto de placas, os direcionadores de fluxo devem ser verificados e corrigidos se necessário. Se as borrachas dos direcionadores de fluxo estiverem danificadas e for necessário a sua substituição, contacte o fabricante.

Substitua a junta entre a placa de cobertura e o rebordo, podem ser encontrados detalhes sobre a junta na folha de Dados Técnicos.

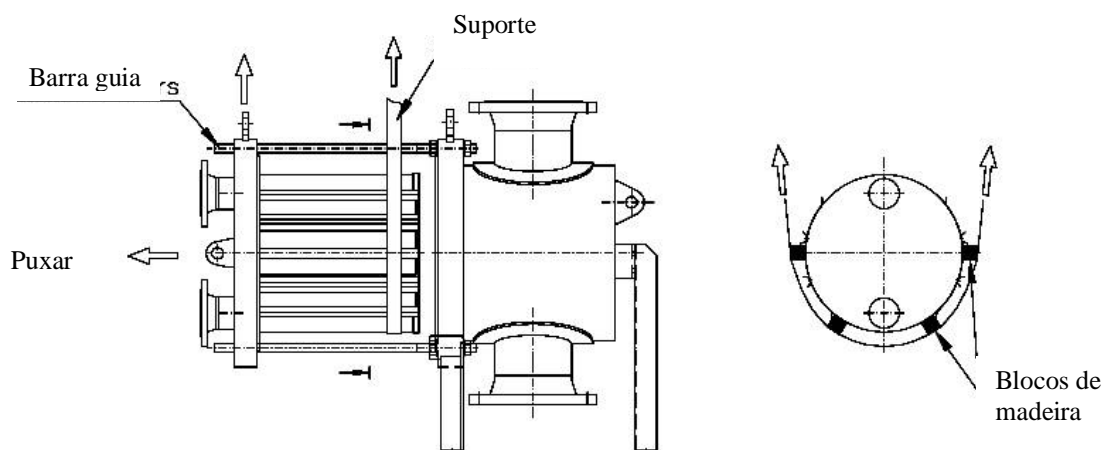
Utilize as barras guia para se assegurar que o conjunto de placas é reposicionado com sucesso e em segurança. Verifique a posição do conjunto de placas relativamente ao invólucro.

Lubrifique as borrachas dos direcionadores de fluxo com óleo vegetal, por exemplo, para facilitar o reposicionamento.

Quando o conjunto de placas estiver a ser montado no invólucro, deve verificar continuamente a posição dos direcionadores de fluxo.

5.3.4 PADRÃO DE APERTO DAS PORCAS/PARAFUSOS

Quando estiver a apertar os parafusos, **nunca** utilize uma ferramenta de impacto. É importante apertar os parafusos com o mesmo valor de torque. Utilize sempre uma chave de torque ou outra ferramenta de aperto calibrada.

A sequência na qual os parafusos são apertados tem um grande impacto na distribuição de pressão na junta. Um aperto incorreto pode colocar o rebordo fora de alinhamento. Uma junta normalmente permite uma pequena distorção deste tipo. Aperte sempre os parafusos num padrão cruzado em estrela. Veja o desenho em baixo, onde a sequência está numerada.

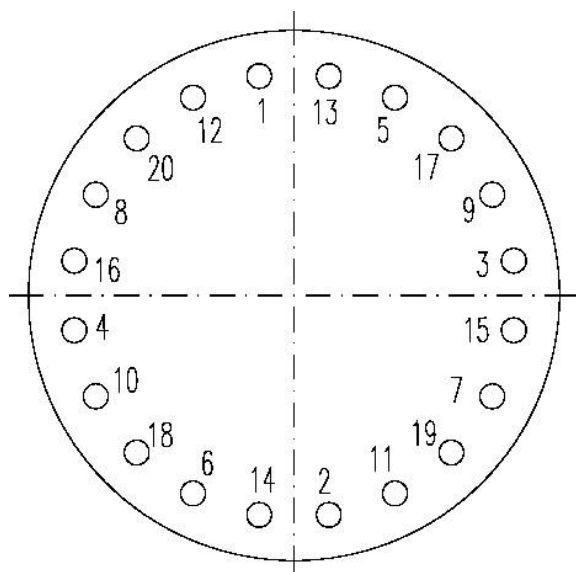

Enrosque sempre a porca ou parafuso à mão. Isto assegura que a rosca se mantém em boas condições (se a porca não apertar à mão, verifique a rosca, substitua se danificada e volte a tentar).

Aperte as conexões usando um mínimo de 5 rotações, seguindo a sequência. É recomendado o seguinte procedimento:

Rotação 1 – Aperte o início da porca manualmente seguindo a sequência, após o qual aperte todos manualmente e uniformemente.

Rotação 2 – Utilizando a chave de torque, aperte os parafusos, seguindo a sequência. Utilize um máximo de 30% do eventual valor de torque. Verifique a posição da junta entre a placa de cobertura e o rebordo.

Rotação 3 – Aperte utilizando 60% do eventual valor de torque, seguindo a sequência.

Rotação 4 – Aperte com o valor total do torque no sentido dos ponteiros do relógio.

O valor do torque de aperto para parafusos lubrificados está mencionado no desenho da disposição geral (GA) fornecido com o permutador.

6 PEÇAS DE SUBSTITUIÇÃO / FERRAMENTAS ESPECIAIS

Permutador de calor que pode ser aberto

- Direcionadores de fluxo
- Conjunto de placas
- Junta entre a placa de cobertura e o rebordo
- Barras guia

Estas peças podem ser fornecidas quando é informado o número de série do permutador.

7 RESOLUÇÃO DE PROBLEMAS

Se o permutador de calor não estiver funcionando devidamente após o início, verifique os seguintes pontos:

Problema	Causa	Verificar	Ação	NOTA
Fraco desempenho	<p>Permutador/ conexões incorretas</p> <p>Pressão</p> <p>Diferença de pressão</p> <p>Temperatura</p> <p>Fluxo de líquido</p>	<p>Verifique a direção dos fluxos nas conexões. Estão de acordo com a concepção/desenho?</p> <p>Verifique a pressão e temperaturas em ambos os lados.</p> <p>Faça a medição das taxas de fluxo e diferenças de pressão.</p> <p>Compare estes valores com dados termodinâmicos da folha técnica do PSHE</p> <p>Verifique a operação da bomba.</p>	<p>Altere as conexões da tubagem. Mude a direção do fluxo.</p> <p>Corrija ou ajuste as válvulas.</p> <p>Substitua as bombas.</p>	<p>Contate o fabricante e forneça os seguintes valores: pressões, diferenças de pressão, temperaturas e taxas de fluxo.</p>
Fuga externa entre a placa de cobertura e o rebordo (modelo que pode ser aberto)	Junta com fuga.	Procure a fuga.	Volte a apertar os parafusos. Se o novo aperto não parar a fuga, remova a placa de cobertura e substitua a junta.	A folha de Dados Técnicos contém os detalhes sobre a junta. Veja o torque de aperto na secção 5.3.4.
Fuga interna (mistura de fluidos)	<p>Placa rachada devido a impacto de água ou choque térmico.</p> <p>Furo na placa devido a corrosão</p> <p>Choque de pressão</p> <p>Desgaste mecânico</p>	<p>Verifique se o líquido do lado da placa é visível do lado do invólucro (o fluido da fuga será visível no tubo de saída).</p> <p>Feche as válvulas do lado da placa ou do invólucro e utilize um medidor para ver se a pressão falha</p> <p>Verifique os dados do processo, se disponíveis.</p> <p>Coloque o invólucro sobre pressão e procure a fuga. Localize a fuga com, por exemplo, um agente colorido.</p>	<p>Contate o fabricante.</p> <p>Contate o fabricante.</p> <p>Contate o fabricante.</p>	

Problema	Causa	Verificar	Ação	NOTA
Muito fraco desempenho e grande diferença de pressão.	Canais do invólucro ou lado da placa entupidos devido ao acúmulo de detritos.	Faça uma medição completa e rigorosa da perda de pressão em ambos os lados para verificar a atual causa do problema.	Limpar permutador de acordo com as instruções (seção 6)	Efetue a manutenção programada / verifique plano de funcionamento.
Degradação gradual no desempenho da permuta de calor.	Filtro entupido	Abra o filtro e verifique a sua condição.	Limpe/substitua o filtro.	Efetue a manutenção programada / verifique plano de funcionamento.
	Válvula e controles do processo.	Verifique a operação das válvulas.	Tome as medidas necessárias: abra, ajuste ou substitua.	
Degradação gradual no desempenho da permuta de calor.	Acúmulo lento de impurezas nas superfícies das placas no lado destas ou no lado do invólucro.	Remova o conjunto de placas (modelo que pode ser aberto) e examine as superfícies do permutador de calor. Modelos soldados podem ser verificados utilizando um endoscópio, se possível. Se o lado do invólucro estiver limpo, o entupimento no lado da placa é responsável pelo retardamento na transferência de calor.	Limpar permutador de acordo com as instruções (seção 6) Substitua a junta e o conjunto de placas (modelos que podem ser abertos).	Efetue a manutenção programada / verifique plano de funcionamento.
	Muito fraco desempenho e baixa diferença de pressão.	Direcionadores de fluxo danificados por choque de pressão ou fluido de processamento impróprio.	Verifique a informação na placa de identificação: estão as temperaturas, e líquidos corretos? Verifique os dados do processo se estiverem disponíveis.	

Se, após verificação, a capacidade do permutador de calor ou a perda de pressão estiverem num nível inaceitável, contate o seu representante Vahterus.

7.1 RELATÓRIO DE RECLAMAÇÃO

Se tiver necessidade de reclamar um produto Vahterus, peça uma notificação de relatório de defeito a sales@vahterus.com.

Por favor inclua o maior número de detalhes possível, e especialmente os seguintes dados:

- Informação geral (número de série)
- Concepção e operação
- Tipo de problema e observações
- Estado do processo

Quando tiver completado o relatório contate um representante da Vahterus.

7.2 MEDIÇÕES PARA SUBSTITUIÇÃO

Se existir a necessidade de substituir o conjunto de placas para um permutador de calor que pode ser aberto, efetue as medições em quatro pontos dentro do invólucro – consulte o diagrama abaixo.

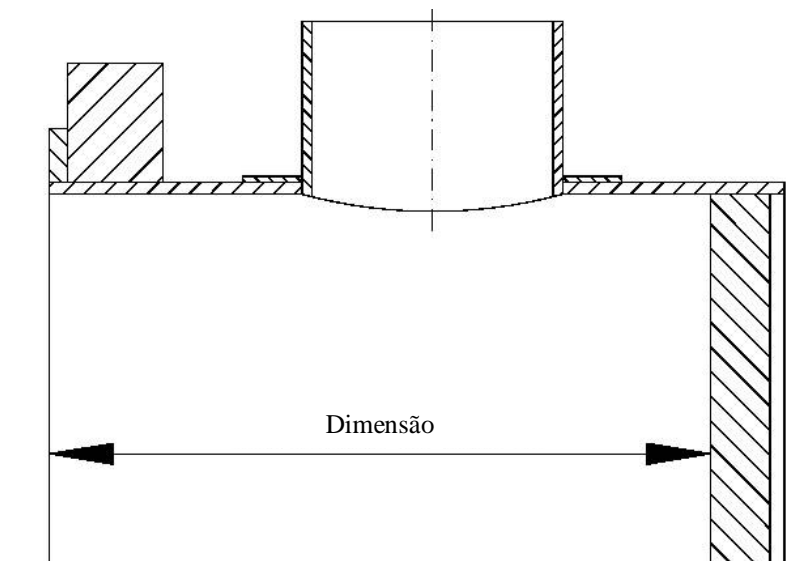

Vahterus Oy
Pruukintie 7
23600 Kalanti
Finlândia
Tel. +358 2 840 70
Fax +358 2.840 7299
sales@vahterus.com





7) NR12

LAUDO DE CONFORMIDADE

EM ATENDIMENTO A NORMA REGULAMENTADORA N° 12,
PORTARIA MTB N.º 98, DE 08 DE FEVEREIRO DE 2018

ENG. RESPONSÁVEL
RENATO CRISTI
ENG. MECÂNICO E
SEGURANÇA DO TRABALHO
CREA 5069876228

LAUDO DE CONFORMIDADE PARA PORTFÓLIO DE
PRODUTOS DE REFRIGERAÇÃO INDUSTRIAL DA EMPRESA
JOHNSON CONTROLS, UNIDADE SOROCABA.

UNIDADE COM COMPRESSOR PARAFUSO
MODELO RWF II 100 ATÉ RWF II 1080

E

UNIDADE DE REFRIGERAÇÃO POR AMÔNIA (PAC)
MODELO PAC 100 ATÉ PAC 1080

Sumário

1.	LISTA DE ABREVIATURAS E SIGLAS	6
2.	OBJETIVO.....	7
3.	INTRODUÇÃO	7
4.	DADOS DA EMPRESA CONTRATANTE	7
5.	DADOS DA EMPRESA CONTRATADA.....	7
6.	REFERÊNCIAS NORMATIVAS.....	8
7.	METODOLOGIA	8
8.	CONCEITOS.....	8
9.	PRINCIPAIS ITENS AVALIADOS	10
10.	IDENTIFICAÇÃO DOS EQUIPAMENTOS	12
10.1.	COMPRESSOR TIPO PARAFUSO, MODELO RWF II 100 ATÉ RWF II 1080.....	12
10.2.	PAC COM COMPRESSOR TIPO PARAFUSO MODELO PAC 100 ATÉ PAC 1080.	15
10.3.	TIPOS DE COMPONENTES	17
11.	IDENTIFICAÇÃO DOS RISCOS.....	19
12.	RISCOS PERTINENTES ÀS UNIDADES RWF II 100 ATÉ RWF II 1080	20
13.	RISCOS PERTINENTES ÀS UNIDADES PAC 100 ATÉ PAC 1080.....	21
14.	AVALIAÇÃO DE RISCO E PROPOSTAS DE REDUÇÃO DE RISCO.....	21
15.	CRITÉRIOS PARA AVALIAÇÃO DE RISCO	22
16.	CLASSIFICAÇÃO DA CATEGORIA APÓS IMPLEMENTAÇÕES RECOMENDADAS	29
17.	IMPLEMENTAÇÕES REALIZADAS NOS EQUIPAMENTOS.....	30
18.	CHECK LIST NR-12.....	32
19.	REFERÊNCIAS TÉCNICAS SOBRE AS NORMAS DE SEGURANÇA	37
20.	CONSIDERAÇÕES FINAIS	38
21.	CONCLUSÃO	38

Lista de Figuras

FIGURA 1 – UNIDADE COMPRESSORA PARAFUSO RWF II COM UNISAB III.....	12
FIGURA 2 – UNIDADE COMPRESSORA PARAFUSO RWF II COM QUANTUM HD.....	13
FIGURA 3 – UNIDADE COMPRESSORA PARAFUSO RWF II COM UNISAB III/QUANTUM HD.....	15
FIGURA 4 – CONTROLADOR UNISAB III.....	17
FIGURA 5 – CONTROLADOR QUANTUM HD.....	18
FIGURA 6 – UNIDADE RWF II.....	20
FIGURA 7 – UNIDADE PAC COM COMPRESSOR PARAFUSO.....	21

Lista de tabelas

TABELA 1 – PORTFÓLIO DE PRODUTOS MODELO RWF II 100 ATÉ RWF II 1080.....	14
TABELA 2 – PORTFÓLIO DE PRODUTOS PAC 100 ATÉ PAC 1080.....	16
TABELA 3 – IDENTIFICAÇÃO DE RISCOS.....	19
TABELA 4 – NÍVEL DE PERFORMANCE E NÍVEL DE INTEGRIDADE DE SEGURANÇA.....	21
TABELA 5 – SISTEMAS DE CLASSIFICAÇÃO DE SEGURANÇA.....	22
TABELA 6 – DETERMINAÇÃO DO PLr.....	24
TABELA 7 – SEVERIDADE / FREQUÊNCIA / POSSIBILIDADE.....	24

1. LISTA DE ABREVIATURAS E SIGLAS

- ABNT** Associação Brasileira de Normas Técnicas
- Cat** Categoria de Segurança equivalente a CC
- CC** Control Category (Categoria de Controle), também conhecida como Categoria de Segurança (B, 1, 2, 3, 4); a categoria já decisivamente dita à qualidade relacionada à segurança de um SRP/CS. Enquanto CC B e CC 1 lida com a qualidade do componente usado, categorias mais altas demandam componentes adicionais (canais) que conseguem compensar a falha de componentes individuais.
- CCF** Common Cause Failure (Falhas de Causa Comum): Falhas com uma causa comum, nas quais componentes que simultaneamente processam a mesma coisa várias vezes por razões de segurança falha na mesma hora. Por exemplo - um carro onde todos os 4 breques têm mal funcionamento na mesma hora.
- DC** Diagnostic Coverage (Cobertura de Diagnóstico): Grau de cobertura de diagnóstico, a capacidade para detectar falhas, que normalmente é automática
- EC** Europe Community (Comunidade Europeia)
- EN** European Standards (Norma Europeia)
- F** Frequência e/ou tempo de exposição (ISO 13849-1:2015)
- FE** Frequência de Exposição (HRN)
- GS** Grau de Severidade (HRN)
- HRN** Hazard Rating Number (Número de classificação do perigo)
- IEC** International Electrotechnical Commission (Comissão Internacional de Eletrotécnica)
- ISO** International Organization for Standardization (Organização Internacional de Normalização)
- MTTFd** Mean Time to Failure dangerous (Tempo Médio para uma Falha Perigosa): Tempo para que uma falha perigosa de um componente ou mecanismo ocorra. Essa informação não deve ser confundida com o serviço de vida garantido.
- NBR** Norma Brasileira de Referência
- NP** Número de Pessoas expostas ao Risco (HRN)
- NR** Norma Regulamentadora
- P** Possibilidade de evitar o dano (ISO 13849-1:2015)
- PFHd** Probabilty of a dangerous Failure per Hour (Probabilidade de falha perigosa por hora).
- PL** Performance Level (Nível de Performance) - ISO 13849-1:2015.
- PLr** Performance Level required (Nível de Performance requerido) - ISO 13849-1:2015.
- PO** Probabilidade de Ocorrer (HRN)
- S** Severidade do ferimento (ISO 13849-1:2015)
- SIL** Safety Integrity Level (Nível de integridade de segurança) - IEC 62061:2015
- SRB** Sicherheits-Relais-Baustein (Relé de Segurança).
- SRP/CS** Safety Related Parts / Control Systems (Parte de Segurança Relacionada de Sistemas de Controle)

2. OBJETIVO

Avaliar as condições de segurança de projeto e fabricação do portfólio de produtos da empresa Johnson Controls BE do Brasil, localizada na cidade do Sorocaba, estado de São Paulo. Apresentar e implementar um plano de ação para reduzir ao máximo os riscos presentes nos equipamentos fabricados pela empresa. Classificá-los na categoria de riscos adequada, utilizando as normas NBR 14.153 e ISO 14.121 como referência, e por fim, emitir ART (Anotação de Responsabilidade Técnica) sobre o portfólio de produtos, assegurando que o engenheiro de segurança no trabalho responsável por este laudo e a companhia Johnson Controls BE do Brasil tomaram todas as medidas protetivas possíveis para tornar os equipamentos produzidos pela empresa adequados à Norma Regulamentadora 12, portaria MTB N.º 98, de 08 de fevereiro de 2018.

3. INTRODUÇÃO

Neste documento serão relatadas as condições de segurança do portfólio de produtos referentes às unidades compressoras do tipo parafuso, modelo RWF II 100 até RWF II 1080 e PAC 100 até PAC 1080.

O procedimento de avaliação de riscos é descrito com os seus requisitos de saúde e segurança essenciais relacionados ao projeto e construção das máquinas, tendo como princípios básicos identificar perigos que possam ser gerados pela máquina, estimar os riscos, levando em consideração a severidade de possíveis lesões e danos à saúde e a probabilidade de seu acontecimento, avaliar os riscos, visando determinar quando a redução de risco é requerida, de acordo com o objetivo das normas de segurança e eliminar ou reduzir os riscos através de medidas de segurança, seguindo procedimentos e normas técnicas, conforme prevê a norma regulamentadora 12 portaria MTB N.º 98, de 08 de fevereiro de 2018.

4. DADOS DA EMPRESA CONTRATANTE

JOHNSON CONTROLS BE DO BRASIL LTDA
AV INDEPENDENCIA, 2757, IPORANGA
SOROCABA - SP, CEP 18087-101
CNPJ: 01.092.686/0023-66
I.E.: 669747350114

5. DADOS DA EMPRESA CONTRATADA

PROTECT ENGENHARIA.
CREA: 2199540 - CNPJ: 27.675.444/0001-83
I.M.: 25.743 - I.E.: 717.158.267.119
ENDEREÇO: RUA MARIA ANTONIETA MAGANHATO BRICHES, 47.
BAIRRO: DOMINGUINHO, VOTORANTIM/SP, CEP 18114-210.

6. REFERÊNCIAS NORMATIVAS

PROFISSIONAL RESPONSÁVEL: RENATO CRISTI

COMPETÊNCIAS: ENG^o MECÂNICO

 ENG^o DE SEGURANÇA DO TRABALHO

REGISTRO (CREA-SP): 5069876228

7. METODOLOGIA

Foram realizadas visitas na fábrica Johnson Controls BE do Brasil, em Sorocaba/SP, para acompanhar a elaboração do projeto e a fabricação de unidades compressoras RWF II e PAC com compressor parafuso. Foram considerados também, avaliação dos manuais técnicos, desenhos das máquinas em 3D e acervos fotográficos. Os riscos foram identificados através de procedimentos previstos nas normas NBR 14.153 e ISO 14.121 e um plano de ação foi adotado para reduzir os riscos presentes nas máquinas. Foi acompanhado todo o processo de implementação do plano de ação e após identificar que as ações recomendadas foram aplicadas nos projetos e máquinas fabricadas pela Johnson Controls BE do Brasil, este laudo de conformidade foi registrado no conselho de Engenharia do Estado de São Paulo pelo responsável técnico apresentado no item 6 deste documento.

8. CONCEITOS

- **Arranjo físico e instalações**

Nos locais de instalação de máquinas e equipamentos, as áreas de circulação devem ser devidamente demarcadas e em conformidade com as normas técnicas oficiais.

As vias principais de circulação nos locais de trabalho e as que conduzem às saídas devem ter no mínimo 1,20 m (um metro e vinte centímetros) de largura. As áreas de circulação devem ser mantidas permanentemente desobstruídas.

Os espaços ao redor das máquinas e equipamentos devem ser adequados ao seu tipo e ao tipo de operação, de forma a prevenir a ocorrência de acidentes e doenças relacionados ao trabalho.

A distância mínima entre máquinas, em conformidade com suas características e aplicações, deve garantir a segurança dos trabalhadores durante sua operação, manutenção, ajuste, limpeza e inspeção, e permitir a movimentação dos segmentos corporais, em face da natureza da tarefa.

As áreas de circulação e armazenamento de materiais e os espaços em torno de máquinas devem ser projetados, dimensionados e mantidos de forma que os trabalhadores e os transportadores de materiais, mecanizados e manuais, movimentem-se com segurança.

- **Máquina**

Elemento que integra a linha, com função predefinida dentro do conjunto ou cadeia de valor.

- **Equipamento**

Componente ou acessório da máquina delimitado por uma função específica.

- **Proteção mecânica fixa**

São aquelas fixadas por parafusos que só podem ser retirados com ferramentas, não podendo ser parafusos do tipo borboleta, manoplas ou de qualquer outra modalidade que permita a sua remoção com as mãos, conforme ABNT NBR NM 272.

- **Proteção mecânica móvel**

São aquelas que permitem movimentação durante o ciclo normal de operação, mas que requerem recurso de intertravamentos de segurança, conforme ABNT NBR NM 273, ou dispositivo de bloqueio, conforme modalidade da máquina e modo de operação e conforme natureza dos riscos.

- **Parada de emergência**

Conforme item 3.1 da NBR 13759, a parada de emergência tem a função de impedir o aumento ou reduzir o risco existente a pessoas e danos à máquina ou ao trabalho em andamento e também de ser iniciada por uma simples ação humana, quando a função de parada normal não for adequada para este fim.

Segundo o item 4.4.3 da NBR 13759 os acionadores de parada de emergência devem ter cor vermelha. Existindo uma superfície posterior ao acionador e, sendo possível, deve ter uma etiqueta na cor amarela com textos na cor preta na língua Portuguesa. Os acionamentos de emergência devem atender as seguintes condições: Botão tipo cogumelo vermelho com acionamento tipo soco, com trava mecânica, que requer a ação de girar para destravar.

Requer rearme manual (reset), ou seja, o destravamento do botão de emergência não pode habilitar o acionamento da máquina sem que seja acionado o botão de rearme;

Garante a pronta parada dos movimentos da máquina;

Monitoramento por interface de segurança (pela sua condição de atuador à distância) deve ser monitorado por interface de segurança adequada, na forma definida pela ABNT NBR NM ISO 1415.

- **Rearme**

Comando obrigatório para ser utilizado após acionamento do comando de emergência da máquina, ou por parada da máquina pelo sistema de intertravamento de segurança das proteções móveis ou pela AOPD. (Active Opto- electronic Protective Device)

A máquina somente poderá ser religada, após o REARME ter sido acionado. Esta atuação não pode permitir a partida da máquina pelo botão liga, sem antes ter sido restabelecida pelo REARME.

Os botões de REARME estão disponíveis nos displays dos controladores Unisab III e Quantum HD.

- **Sinalização de segurança conforme NR-26**

A sinalização tem como objetivo chamar a atenção dos operadores sobre os riscos existentes no local, para que possam adotar as medidas de controles seguras para o trabalho e devem atender os requisitos da NR-26 na íntegra.

9. PRINCIPAIS ITENS AVALIADOS

- **Proteção fixa**

Proteção fixada de tal modo (por exemplo: parafusos, porcas, soldagem) que somente poderá ser aberta ou removida com o uso de ferramentas ou destruição do meio de fixação.

- **Instalações e dispositivos elétricos**

As instalações elétricas das máquinas e equipamentos devem ser projetadas e mantidas de modo a prevenir, por meios seguros, os perigos de choque elétrico, incêndio, explosão e outros tipos de acidentes, conforme previsto na NR 10.

Devem ser aterrados, conforme as normas técnicas oficiais vigentes, as instalações, carcaças, invólucros, blindagens ou partes condutoras das máquinas e equipamentos que não façam parte dos circuitos elétricos, mas que possam ficar sob tensão.

- **Perigos elétricos**

10.2 Medidas de controle

10.2.8 Medidas de proteção coletiva

10.2.9 Medidas de proteção individual

10.3 Segurança em projetos

10.4 Segurança na construção, montagem, operação e manutenção

10.5 Segurança em instalações elétricas desenergizadas

- 10.6 Segurança em instalações elétricas energizadas
- 10.8 Habilitação, qualificação, capacitação e autorização dos trabalhadores
- 10.9 Proteção contra incêndio e explosão
- 10.10 Sinalização de segurança
- 10.12 Situação de emergência

- **Ergonomia**

Item 12.102 que menciona: "os locais destinados ao manuseio de materiais em processos nas máquinas e equipamentos devem ter altura e ser posicionados de forma a garantir as boas condições posturais, visualização, movimentação e operação".

- **Partes quentes**

Devem ser adotadas medidas de proteção contra queimaduras causadas pelo contato da pele com superfícies aquecidas de máquinas e equipamentos, tais como a redução da temperatura superficial, isolamento com materiais apropriados e barreiras, sempre que a temperatura da superfície for maior do que o limiar de queimaduras do material do qual é constituída, para um determinado período de contato.

De acordo com a norma de segurança de máquinas ABNT NBR 13970, medidas de engenharia, organizacionais e de proteção individual podem ser aplicadas, isoladas ou combinadas para proteções contra queimaduras.

- **Textos em português**

Item 12.119. As inscrições das máquinas e equipamentos devem:
a) ser escritas na língua portuguesa - Brasil; e b) ser legíveis.

- **Plaqueta indelével**

Item 12.123. As máquinas e equipamentos fabricados a partir da vigência desta Norma (24.12.2010) devem possuir em local visível as seguintes informações indeléveis:

- a) razão social, CNPJ e endereço do fabricante ou importador;
- b) informação sobre tipo, modelo e capacidade;
- c) número de série ou identificação, e ano de fabricação;
- d) número de registro do fabricante/importador ou do profissional legalmente habilitado no CREA
- e) peso da máquina ou equipamento.

10. IDENTIFICAÇÃO DOS EQUIPAMENTOS

10.1. COMPRESSOR TIPO PARAFUSO, MODELO RWF II 100 ATÉ RWF II 1080.

Equipamento concebido para uso industrial destinado a sistemas de refrigeração, composto por motor elétrico, sistema compressor do tipo parafuso com carcaça fundida em aço especial com rotores assimétricos e permite a regulação da vazão do volume interno. Utiliza filtro de sucção de fácil limpeza e seu acionamento é feito através de um eixo macho e permite a regulação da capacidade contínua de 10% a 100%. O equipamento é capaz de operar com praticamente todos os tipos de fluidos refrigerantes.



Figura 1 - Unidade Compressora tipo Parafuso RWF II com Controlador Unisab III

Todo o sistema é comandado por controladores dedicados para refrigeração industrial. Este laudo assegura a utilização de dois modelos de controladores, sendo eles intitulados como Unisab III ou Quantum HD Unity Compressor. Estes controladores possuem a capacidade de controlar a pressão, temperatura, superaquecimento de sucção e descarga, pressão de óleo, corrente do motor, capacidade do compressor, horímetro e causas de mensagem de alerta e alarme. Seus parâmetros de segurança estão em conformidade com a NR-12.



Figura 2 - Unidade Compressora Parafuso RWF II com Controlador Quantum HD

A tabela a seguir contempla todo o portfólio de produtos de compressores tipo parafuso modelo RWF II 100 até RWF II 1080. A análise preliminar, classificação de riscos, ações de contenção e validade deste laudo atende a todo portfólio, visto que os riscos a serem contidos são os mesmos para qualquer um dos modelos do manual.

Informações adicionais ao equipamento podem ser acessados através do manual do fabricante (70.610-IOM).

Modelo RWF II	Modelo Compressor	Máxima Rotação [RPM]	Potência do motor Elétrico [HP]	Tensão de Alimentação [VCA]	Frequência [Hz]	Tipo de Partida	Tensão de Comando para Operador [VCC]								
100	SGC 1913	4500	60 até 1000	220	50	Controlador Inversor de Frequência	24								
119 SS															
134	SGC 1918														
159 SS															
177	SGC 2313	4500						440	60	Chave de partida Tipo Softstarter	24				
209 SS															
222	SGC 2317														
264 SS															
270	SGC 2321														
316	SGC 2813	4200										460	50	Chave de partida Tipo Softstarter	24
375 SS															
399	SGC 2817														
472 SS															
480	SGC 2821														
546	SGC 2824														
496	SGCH/B 3511	3600	480	60	Chave de partida Tipo Softstarter	24									
676	SGCH/B3515														
856	SGCH/B 3519														
	SGXH/B 3519														
1080	SGXH 3524														

Tabela 1: Portfólio de Produtos modelo RWF II 100 até RWF II 1080.

10.2. PAC COM COMPRESSOR TIPO PARAFUSO MODELO PAC 100 ATÉ PAC 1080.

Uma unidade resfriadora de líquido PAC é uma máquina que trabalha com amônia como fluido refrigerante e é baseada no ciclo de refrigeração por compressão de vapor. O fluido refrigerante é succionado do separador de líquido na forma de vapor de baixa pressão e é comprimido pelo compressor de gases até um nível de pressão superior. É conduzido ao condensador, onde passa de vapor superaquecido para líquido sub-resfriado, através da troca de calor em um trocador de calor do tipo placas, aquecendo água de torre. Através de um controle de nível, este refrigerante é expandido e entra no evaporador como uma mistura bifásica de líquido e vapor. Circulando através das placas do evaporador, ele vai evaporando e trocando calor com o fluido secundário que está sendo resfriado. Ao final deste resfriamento do produto, a amônia segue para o separador de líquido, onde acontecerá a separação do líquido e do vapor – o qual será, novamente, succionado pelo compressor. O chiller PAC é um sistema auto-circulante que trabalha pelo princípio de termossifão no evaporador, dispensando o uso de bombas de amônia para circulação. Assim como as unidades compressoras RWF II, as unidades PAC também possuem suas variações, conforme tabela abaixo. A análise preliminar, classificação de riscos, ações de contenção e validade deste laudo atende a todo portfólio, visto que os riscos a serem contidos são os mesmos para qualquer um dos modelos do manual. Informações adicionais ao equipamento podem ser acessados através do manual do fabricante.



Figura 3 - Unidade Compressora Parafuso RWF II com controlador Unisab III ou Quantum HD

Modelo PAC	Modelo RWF II	Modelo Compressor	Máxima Rotação [RPM]	Potência do motor Elétrico [HP]	Tensão de Alimentação [VCA]	Frequência [Hz]	Tipo de Partida	Tensão de Comando [VCC]
PAC 100	100	SGC 1913	4500	60 A 1000	220 Ou 380 Ou 440 Ou 460 Ou 480	50 Ou 60	Controlador Inversor de Frequência	24
PAC 119	119 SS							
PAC 134	134	SGC 1918						
PAC 159	159 SS							
PAC 177	177	SGC 2313	4500					
PAC 209	209 SS							
PAC 222	222	SGC 2317						
PAC 264	264 SS							
PAC 270	270	SGC 2321						
PAC 316	316	SGC 2813					4200	
PAC 375	375 SS							
PAC 399	399	SGC 2817						
PAC 472	472 SS							
PAC 480	480	SGC 2821						
PAC 546	546	SGC 2824						
PAC 496	496	SGCH/B 3511	3600					
PAC 676	676	SGCH/B3515						
PAC 856	856	SGCH/B 3519						
		SGXH/B 3519						
PAC 1080	1080	SGXH 3524						

Tabela 2: Portfólio de Produtos PAC 100 até PAC 1080.

10.3. TIPOS DE COMPONENTES

- **Compressor Tipo Parafuso**

Uma máquina de deslocamento positivo que possui dois rotores acoplados, montados em mancais para fixar suas posições na câmara de trabalho numa tolerância estreita em relação à cavidade cilíndrica. A máquina tem o objetivo de comprimir fluido refrigerante.

- **Chave de Partida Tipo Softstarter**

Entende-se como Softstarter um dispositivo eletrônico composto por pontes de tiristores (SCR's) acionadas por um circuito eletrônico, com a finalidade de controlar a tensão de partida do motor, bem como sua deserregização.

- **Controlador Inversor de Frequência**

Entende-se como inversor de frequência um tipo de controlador que tem a função de acionar um motor elétrico e ao mesmo tempo variar a frequência e a tensão que é fornecida ao motor com o objetivo de controlar a sua velocidade e potência consumida.

- **Motor Elétrico**

Entende-se como motor elétrico tipo gaiola de esquilo uma máquina destinada a converter energia elétrica em energia mecânica.

- **Controlador Unisab III**

Compreende-se controlador Unisab III como um controlador lógico dedicado para Refrigeração Industrial, que tem a finalidade de controlar unidades compressoras Tipo Parafuso e Alternativo (Pistões). Este controlador foi desenvolvido pela empresa Sabroe, marca propriedade da empresa Johnson Controls.



Figura 4 - Controlador Unisab III

- **Controlador Quantum HD**

Compreende-se controlador Quantum HD Unity Compressor como um controlador lógico dedicado para Refrigeração Industrial, que tem a finalidade de controlar unidades compressoras Tipo Parafuso e Alternativo (Pistões). Este controlador foi desenvolvido pela empresa Frick, marca propriedade da empresa Johnson Controls. Manual de operação do Quantum HD conforme NR 10



Figura 5 - Controlador Quantum HD

11. IDENTIFICAÇÃO DOS RISCOS

Riscos Mecânicos

Base Normativa: ABNT NBR ISO 12.100; ABNT NBR I 4.153; EN/ISO 14.121 - Tabela B.1

Item	Origem	Risco Existente (x)
1	Aceleração, Desaceleração	
2	Cantos Vivos	X
3	Aproximação de um Elemento Móvel a uma Parte Fixa	
4	Corte De Peças	
5	Elementos Elásticos	
6	Queda De Objetos	
7	Gravidade	
8	Altura A Partir Do Solo	X
9	Alta Pressão	X
10	Instabilidade	
11	Energia Cinética	X
12	Mobilidade Da Máquina	
13	Elementos Móveis	
14	Elementos Rotativos	X
15	Superfície Áspera, escorregadia	
16	Arestas Cortantes	
17	Energia Armazenada	X
18	Vácuo	

Item	Consequências Potenciais	
1	Atropelamento	
2	Arremessos	X
3	Esmagamento	
4	Corte Ou Mutilação	
5	Segurar Ou Prender	
6	Enroscar	
7	Fricção Ou Abrasão	
8	Impacto	X
9	Injeção	X
10	Raspagem	
11	Escorregamento, Tropeço E Queda	X
12	Perfuração	
13	Sufocamento	

Riscos Elétricos

BASE NORMATIVA: ABNT NBR ISO 12.100; ABNT NBR I 4.153; EN/ISO 14.121 - Tabela B.1

Item	Origem	Risco Existente (x)
1	Arcos	
2	Fenômenos Eletromagnéticos	X
3	Partes Vivas	
4	Baixa Rigidez Dielétrica	
5	Partes Vivas Sobre Condições de Falhas	
6	Curtos Circuitos	X
7	Radiação Térmica	X

Item	Consequências Potenciais	Risco Existente (x)
1	Queimadura	X
2	Efeitos Químicos	X
3	Efeitos em Implantes Médicos	
4	Eletrocussão, Choque	X
5	Queda ou Arremesso	
6	Incêndio	X
7	Projeção de Fagulhas	

12. RISCOS PERTINENTES ÀS UNIDADES RWF II 100 ATÉ RWF II 1080

Os pontos críticos onde se apresentam os riscos estão indicados na ilustração a seguir.



Figura 6 – Unidade RWF II

13. RISCOS PERTINENTES ÀS UNIDADES PAC 100 ATÉ PAC 1080

Os pontos críticos onde se apresentam os riscos estão indicados na ilustração a seguir.

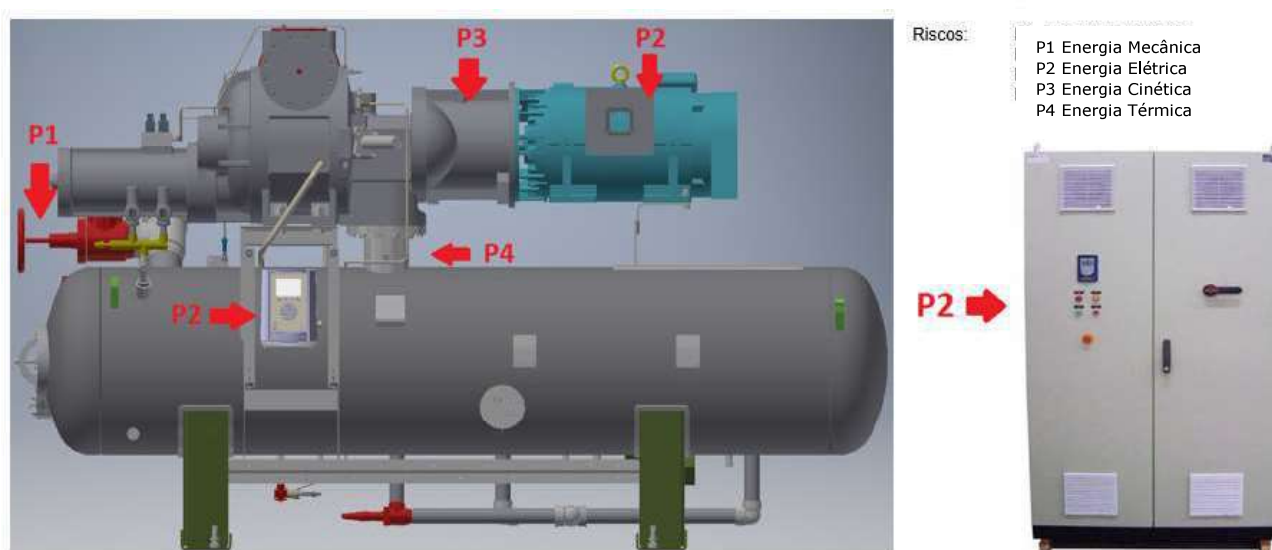

Figura 7 – Unidade PAC

14. AVALIAÇÃO DE RISCO E PROPOSTAS DE REDUÇÃO DE RISCO

Durante a avaliação de risco das máquinas, será usada a ABNT NBR ISO 12100:2013.

Na ABNT NBR ISO 12100:2013, as bases e princípios de diretrizes gerais pedem uma análise de risco, além disso, a norma ABNT NBR ISO 12100:2013 especifica princípios de diretrizes técnicas, a fim de dar suporte aos projetistas técnicos para projetar máquinas seguras.

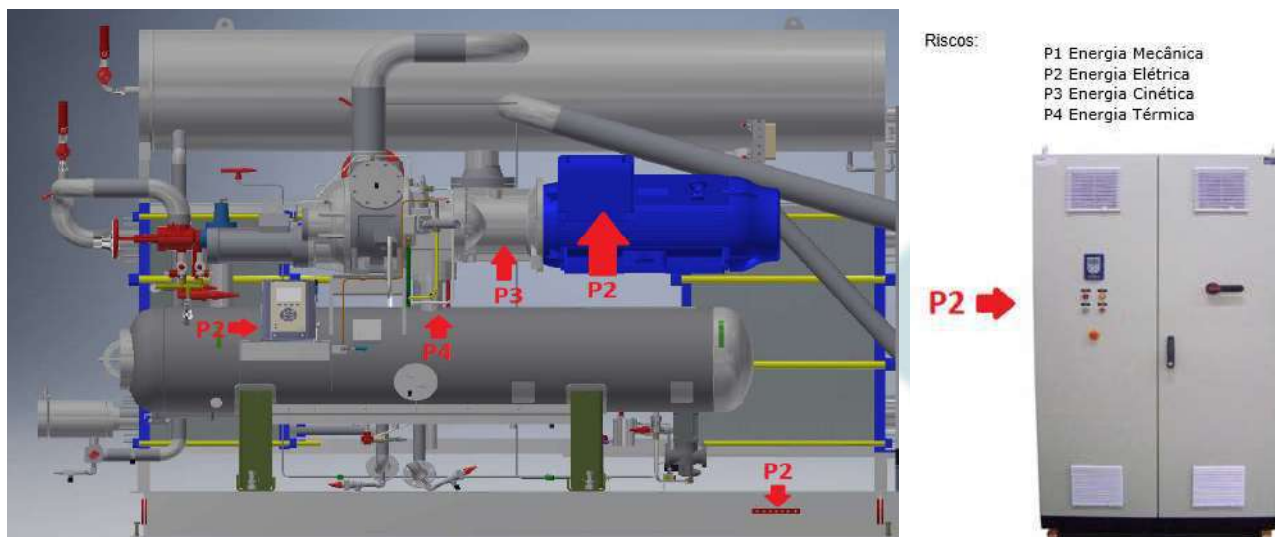
A avaliação de riscos das máquinas e a determinação do nível de performance requerido (PLr) é feita utilizando a ISO 13849-1:2015 e comparada com o nível de integridade de segurança (SIL) especificado na norma IEC 62061:2015 utilizando o valor PFH para quantificar as probabilidades de falhas perigosas por hora conforme tabela a seguir:

ISO 13849-1 Nível de performance (PL)	Probabilidade de falha perigosa por hora (PFH _d)	IEC 62061 Nível de integridade de segurança (SIL)
a	$10^{-5} \leq PFH_d < 10^{-4}$	Nenhum
b	$3 \times 10^{-6} \leq PFH_d < 10^{-5}$	1
c	$10^{-6} \leq PFH_d < 3 \times 10^{-6}$	1
d	$10^{-7} \leq PFH_d < 10^{-6}$	2
e	$10^{-8} \leq PFH_d < 10^{-7}$	3

Tabela 4: Comparação entre nível de performance e nível de integridade de segurança

O Brasil adota as categorias de segurança B, 1, 2, 3 e 4 segundo ABNT NBR 14.153 que é encontrada comparando o nível de performance requerido (PLr) com o sistema brasileiro conforme tabela abaixo:

IEC 62061 Nível de Integridade de Segurança (SIL)	IEC 61508 Nível de Integridade de Segurança (SIL)	ISO 13849-1 Nível de Performance requerido (PLr)	ABNT NBR 14153 Categoria (Cat)
-	-	a	B
1	1	b	1
2	2	c	2
3	3	d	3
	4	e	4

Tabela 5: Sistemas de Classificação de Segurança

15. CRITÉRIOS PARA AVALIAÇÃO DE RISCO

Os critérios de avaliação de riscos usados pela PROTECT ENGENHARIA são baseados na norma ISO 13849:2015.

De acordo com ABNT NBR ISO 12100:2013 uma estimativa de risco e avaliação será providenciada para cada perigo determinado. As fases da vida de uma máquina nas quais os perigos foram identificados ou foram considerados significantes foram consideradas neste documento.

• CATEGORIZAÇÃO DE SEGURANÇA

Conforme a norma ISO 13849:2015, nas partes da máquina que apresentam riscos serão detalhadas as informações de Severidade do ferimento, Frequência e/ou tempo de exposição e Possibilidade de evitar o dano, determinando assim o nível de performance requerido (PLr), SIL (Safety Integrity Level, ou Nível de integridade de segurança) e Categoria de Segurança a ser adotada (B,1,2,3 ou 4).

• SEVERIDADE S1 E S2

A severidade do ferimento pode ser estimada considerando-se a gravidade de lesões ou danos à saúde, que podem ser leves, graves ou fatais, e a extensão do dano, causado à uma pessoa ou várias pessoas.

Ao realizar-se uma avaliação de risco, o risco a ser considerado para cada perigo, deve ser aquele relativo à severidade mais provável, por sua vez, referente ao dano

mais provável, entretanto, a maior gravidade previsível deve também ser levada em consideração, mesmo que a probabilidade de tal ocorrência não seja alta.

O anexo A da ISO 13849:2015 determina a severidade em duas partes S1 e S2 onde, as consequências normais de cura devem ser levadas em consideração na determinação de S1 e S2, por exemplo, contusões e/ou lacerações, sem complicações devem ser classificadas como S1, enquanto uma amputação ou morte deve ser classificada como S2.

- **FREQUÊNCIA F1 E F2**

Conforme o anexo A da ISO 13849:2015, um período de tempo geralmente válido para a escolha do parâmetro F1 ou F2 não pode ser especificado. Entretanto, a seguinte explicação pode ajudar a tomar a decisão correta, em caso de dúvida.

F2 deve ser selecionado, se a pessoa estiver, frequentemente ou continuamente, exposta ao perigo. É irrelevante se a mesma pessoa ou pessoas diferentes estiverem expostas ao perigo em sucessivas ocasiões, como, por exemplo, para a utilização de elevadores.

- **POSSIBILIDADE DE EVITAR O DANO P1 E P2**

Quando um perigo aparece, é importante saber se ele pode ser reconhecido e quando pode ser evitado, antes de levar a um acidente. Por exemplo, uma importante consideração é se o perigo pode ser diretamente identificado por suas características físicas ou por meios técnicos, por exemplo, indicadores. Outro aspecto importante que influencia a seleção do parâmetro P inclui, por exemplo:

- Operação com ou sem supervisão;
- Operação por especialistas ou por não profissionais;
- Velocidade com que o perigo aparece, por exemplo, rapidamente ou lentamente;
- Possibilidades de se evitar o perigo, por exemplo, por fuga ou por intervenção de terceiros;
- Experiências práticas de segurança relativas ao processo.

Quando uma situação de perigo ocorre, P1 deve apenas ser selecionado se houver uma chance real de se evitar um acidente ou reduzir significativamente o seu efeito. P2 deve ser selecionado se praticamente não houver chance de se evitar o perigo, conforme anexo A da ISO 13849:2015.

• **DETERMINAÇÃO DO NÍVEL DE PERFORMANCE REQUERIDO PL_r**

Para atingir o nível de performance requerido PL_r deve-se partir do ponto inicial, selecionar o parâmetro de severidade, posteriormente a frequência e finalmente a possibilidade de evitar o dano, obtendo desta maneira um caminho até o PL_r entre PL_a, PL_b, PL_c, PL_d e PL_e, onde PL_a equivale a baixa contribuição para reduzir o risco (L) e PL_e equivale a alta contribuição para reduzir o risco (H).



Tabela 6: Determinação do PL_r

S Severidade do ferimento	S1: Lesão leve, geralmente reversível S2: Grave, geralmente irreversível, de uma ou mais pessoas e morte
F Frequência e/ou tempo de exposição	F1: De raramente a nunca F2: De frequentemente a continuamente
P Possibilidade de evitar o dano	P1: Possível sobre certas condições P2: Praticamente impossível

Tabela 7: Severidade / Frequência / Possibilidade.

• **ESPECIFICAÇÕES DE CATEGORIAS DE SEGURANÇA**

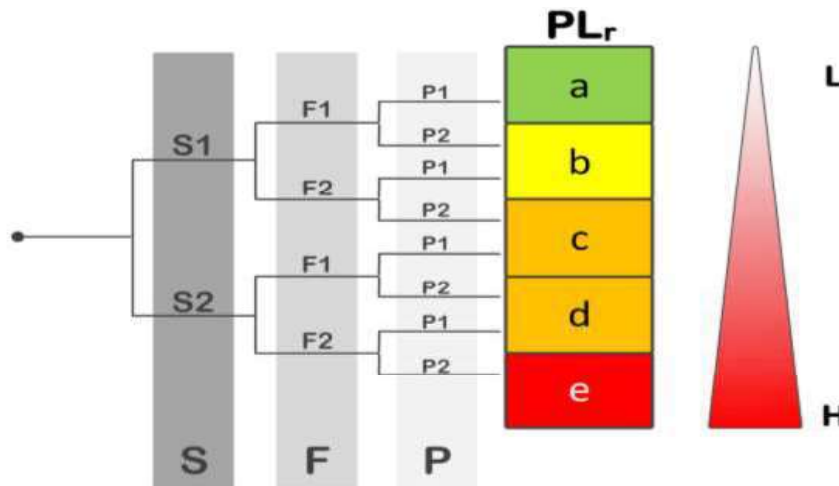
Categoria de Segurança é a classificação das partes de um sistema de comando relacionadas à segurança, com respeito à sua resistência aos defeitos e seu subsequente comportamento na condição de defeito, que é alcançada pela combinação e interligação das partes e/ou por sua confiabilidade. O desempenho

com relação a ocorrência de defeitos, de uma parte de um sistema de comando, relacionado a segurança, é dividido em cinco categorias (B, 1, 2, 3 e 4) segundo a norma ABNT NBR 14153 - Segurança de máquinas - Partes de sistemas de comando relacionadas a segurança - Princípios gerais para projeto, equivalente a norma EN 954-1 - Safety of machinery - Safety related parts of control systems, que leva em conta princípios qualitativos para sua seleção. A norma EN 954-1 foi substituída pela norma ISO 13849-1:2015 - Safety of machinery - Safety related parts of control systems, que estabelece critérios quantitativos, não mais divididos em categorias, mas em níveis de "A" a "E", sendo que o "E" é o mais elevado. Para seleção do nível, denominado "performance level" - PL, é necessária a aplicação de complexa fórmula matemática em função da probabilidade de falha dos componentes de segurança selecionados Safety Integrity Level - SIL, informado pelo fabricante do componente. Pode-se dizer que um determinado componente de segurança com característica SIL3, equivalente ao nível de performance requerido PLr igual a PLe atende aos requisitos da categoria 4, conforme tabela 4.

• **CATEGORIA DE SEGURANÇA B**

As partes de sistemas de comando relacionadas à segurança, como mínimo, devem ser projetadas, construídas, selecionadas, montadas e combinadas, de acordo com as normas relevantes, usando os princípios básicos de segurança para a aplicação específica, de tal forma que a:

- Fadiga operacional prevista, como, por exemplo, detergentes em máquinas de lavar;
- Influência do material processado ou utilizado no processo, como, por exemplo,

Vibrações mecânicas, campos externos, distúrbios ou interrupção de fornecimento de energia.

• **CATEGORIA DE SEGURANÇA 1**

Devem ser aplicados os requisitos da categoria de segurança B e os desta subseção.

As partes de sistemas de comando relacionadas à segurança, de categoria 1, devem ser projetadas e construídas utilizando-se componentes bem ensaiados e princípios de segurança comprovados.

Um componente bem ensaiado para uma aplicação relacionada à segurança é aquele que tenha sido:

- Largamente empregado no passado, com resultados satisfatórios em aplicações similares, ou:

- Construído e verificado utilizando-se princípios que demonstrem sua adequação e confiabilidade para aplicações relacionadas à segurança.

Em alguns componentes bem ensaiados, certos defeitos podem também ser excluídos, em razão de ser conhecida a incidência de defeitos e esta ser muito baixa.

A decisão de se aceitar um componente particular como bem ensaiado pode depender de sua aplicação.

- **CATEGORIA DE SEGURANÇA 2**

Devem ser aplicados os requisitos da categoria de segurança B, o uso de princípios de segurança comprovados e os requisitos desta subseção.

As partes de sistemas de comando relacionadas à segurança, de categoria de segurança 2, devem ser projetadas de tal forma que sejam verificados em intervalos adequados pelo sistema de comando da máquina. A verificação das funções de segurança deve ser efetuada:

- Na partida da máquina e antes do início de qualquer situação de perigo, e:
- Periodicamente durante a operação, se a avaliação do risco e o tipo de operação mostrar que isso é necessário.
- O início dessa verificação pode ser automático ou manual.
- Qualquer verificação das funções de segurança deve:
- Permitir a operação se nenhum defeito foi constatado, ou:
- Gerar um sinal de saída, que inicia uma ação apropriada do comando, se um defeito foi constatado.

Sempre que possível este sinal deve comandar um estado seguro. Quando não for possível comandar um estado seguro, como, por exemplo, fusão de contatos no dispositivo final de comutação, a saída deve gerar um aviso do perigo.

A verificação por si só não deve levar a uma situação de perigo. O equipamento de verificação pode ser parte integrante, ou não, das partes relacionadas à segurança, que processam a função de segurança. Após a detecção de um defeito, o estado seguro deve ser mantido até que o defeito tenha sido sanado.

- **CATEGORIA DE SEGURANÇA 3**

Devem ser aplicados os requisitos da categoria de segurança B, o uso de princípios comprovados de segurança e os requisitos desta subseção. Partes relacionadas à segurança de sistemas de comando categoria 3 devem ser projetadas de tal forma que um defeito isolado, em qualquer dessas partes, não leve à perda das funções de segurança.

Defeitos de modos comuns devem ser considerados, quando a probabilidade da ocorrência de tal defeito seja significativa. Sempre que, razoavelmente praticável, o

defeito isolado deve ser detectado durante, ou antes, da próxima solicitação de segurança.

O acúmulo de defeitos não detectados pode levar à perda da função de segurança.

- **CATEGORIA DE SEGURANÇA 4**

Devem ser aplicados os requisitos da categoria de segurança B, o uso de princípios comprovados de segurança e os requisitos desta subseção.

Partes de sistemas de comando relacionadas à segurança, de categoria de segurança 4, devem ser projetadas de tal forma que:

- Uma falha isolada em qualquer dessas partes relacionadas à segurança não leve à perda das funções de segurança, e:
- A falha isolada é detectada antes ou durante a próxima atuação sobre a função de segurança, como, por exemplo, imediatamente, ao ligar o comando, ao final do ciclo de operação da máquina. Se essa detecção não for possível, o acúmulo de defeitos não deve levar à perda das funções de segurança.

Se a detecção de certos defeitos não for possível ao menos durante a verificação seguinte a ocorrência do defeito por razões de tecnologia ou engenharia de circuitos, a ocorrência de defeitos posteriores deve ser admitida. Nessa situação, o acúmulo de defeitos não deve levar à perda das funções de segurança.

- **GRAU DE SEVERIDADE (GS)**

Grau de Severidade (GS)	Peso
Arranhão / Contusão / Escoriação	0,1
Dilaceração / Cortes / Doenças Moderadas	0,5
Fratura ossos menores / Enfermidade Leve	1
Fratura ossos importantes / Enfermidade Grave	2
Perda de 1 membro / olho	4
Perda de 2 membros / olhos	8
Enfermidade permanente ou crítica	12
Fatalidade	15

- **FREQUÊNCIA DE EXPOSIÇÃO (FE)**

Frequência de Exposição (FE)	Peso
Anualmente	0,5
Mensalmente	1
Semanalmente	1,5
Diariamente	2,5
Em termos de hora	4
Constantemente	5

• **PROBABILIDADE DE OCORRÊNCIA (PO)**

Probabilidade de Ocorrer (PO)	Peso
Quase impossível	0,033
Altamente improvável	1
Improvável	1,5
Possível	2
Alguma chance	5
Provável	8
Muito Provável	10
Certo	15

• **NÚMERO DE PESSOAS (NP)**

Número de Pessoas Expostas ao Risco (NP)	Peso
1-2 pessoas	1
3-7 pessoas	2
8-15 pessoas	4
16-50 pessoas	8
Mais que 50 pessoas	12

Após a determinação dos fatores acima, deverá ser realizado o cálculo para determinar o valor do HRN que indicará o Grau de Risco.

$$\text{HRN} = \text{GS} \times \text{FE} \times \text{PO} \times \text{NP}$$

O HRN é comparado com a tabela a seguir que determina o valor do risco em cada proteção da máquina

Nível de Risco HRN	
0 - 5	Desprezível
5 - 50	Baixo, porém significativo
50 - 500	Alto
500 +	Inaceitável

Desprezível - Risco muito baixo, medidas preventivas propostas insignificantes, se houver, são opcionais. Informações de riscos residuais.

Baixo, porém, significativo - Deve-se tomar medidas preventivas e avaliá-las considerando a viabilidade técnica e econômica, bem como a informação sobre o risco residual após as medidas.

Alto - Medidas de prevenção são necessárias ou recomendadas na Avaliação de Riscos, resultando em uma redução do risco.

Inaceitável - É necessário refazer o projeto independente do custo. Não se pode colocar no mercado ou em operação esta instalação sem ter realizada a reformulação para esse risco.

16. CLASSIFICAÇÃO DA CATEGORIA APÓS IMPLEMENTAÇÕES RECOMENDADAS

Classificação de riscos com base na NBR 14.153 (Análise de Riscos).

(ABNT) ANÁLISE DE RISCOS - ABNT NBR 14.153			
(S)	(F)	(P)	CATEGORIA
SEVERIDADE	FREQUÊNCIA	POSSIBILID. DE EVITAR	
(S2)	(F1)	(P1)	B
(S) SEVERIDADE DO FERIMENTO			
(S1) LEVE (REVERSÍVEL)			
(S2) GRAVE (IRREVERSÍVEL) INCLUSIVE FATAL			
(F) FREQUÊNCIA E TEMPO DE EXPOSIÇÃO			
(F1) RARAMENTE E OU PEQUENA EXPOSIÇÃO			
(F2) FREQUENTE ATÉ CONTÍNUO E OU LONGA EXPOSIÇÃO			
(P) POSSIBILIDADE DE EVITAR O PERIGO			
(REFEREM-SE GERALMENTE À VELOCIDADE E FREQUÊNCIA COM A QUAL A PEÇA ANALISADA MOVIMENTA-SE E A DISTÂNCIA DO OPERADOR DA MESMA			
(P1) POSSÍVEL SOB DETERMINADAS CONDIÇÕES			
(P2) POUCO POSSÍVEL			

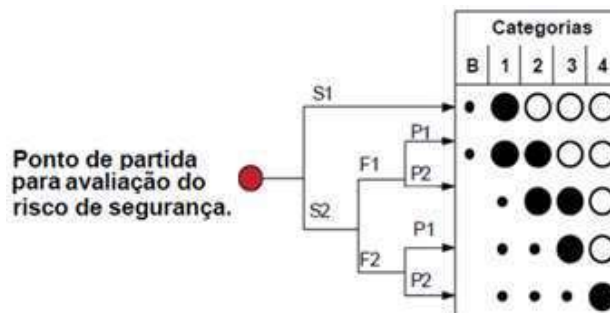

Classificação de riscos com base na ISO 14.121 (Análise de Riscos)

(ISO) ANÁLISE DOS RISCOS - EN/ISO 14.121						
HRN = Se x Fr x Pr x NP						
(Se)	(Fr)	(Pr)	(Np)	(HRN)	CATEGORIA	
SEVERIDADE	FREQUÊNCIA	PROBABILIDADE	PESSOAS EXPOSTAS			
2	0,1	1	1	0,2	B	
DANO (SEVERIDADE)			Se	N. PESSOAS EXPOSTAS		Fr
MORTE			15	MAIS DE 50 PESSOAS		12
PERDA DE 2 MEMBROS/OLHOS OU DOENÇA GRAVE (IRREVERSÍVEL)			8	16-50 PESSOAS		8
PERDA DE 1 MEMBRO/OLHO OU DOENÇA GRAVE (TEMPORÁRIA)			4	08-15 PESSOAS		4
FRATURA - OSSOS IMPORTANTES OU DOENÇA LEVE (PERMANENTE)			2	03-07 PESSOAS		2
FRATURA - OSSOS MENORES OU DOENÇA LEVE (TEMPORÁRIA)			1	01-02 PESSOAS		1
LACERAÇÃO/EFEITO LEVE NA SAÚDE			0,5			
ARRANHÃO/CONTUSÃO			0,1			
PROBABILIDADE DE OCORRÊNCIA DO DANO		Pr	FREQUÊNCIA DE EXPOSIÇÃO AO RISCO		Fr	
CERTAMENTE		15	CONSTANTEMENTE		5	
ESPERADO		10	HORÁRIO		4	
PROVÁVEL		8	DIARIAMENTE		2,5	
ALGUMA CHANCE		5	SEMANAL		1,5	
POSSÍVEL		2	MENSAL		1	
NÃO ESPERADO		1	ANUAL		0,2	
IMPOSSÍVEL		0,03	RARAMENTE		0,1	
HRN	RISCO	DESCRIÇÃO			AÇÃO	
0-5	INSIGNIFICANTE	OFERECE RISCO MUITO BAIXO P/A SEGURANÇA E SAÚDE			NENHUMA AÇÃO REQUERIDA	
5-50	BAIXO PORÉM SIGNIFICATIVO	CONTÉM RISCOS NECESSÁRIOS PARA A IMPLEMENTAÇÃO DE MEDIDAS DE CONTROLE DE SEGURANÇA			MELHORIA RECOMENDADA	
50-500	ALTO	OFERECE POSSÍVEIS RISCOS, NECESSÁRIOS QUE SEJAM UTILIZADAS MEDIDAS DE CONTROLE DE SEG. URGENTES			NECESSÁRIA AÇÃO DE MELHORIA	
500+	INACEITÁVEL	É INACEITÁVEL MANTER A OPERAÇÃO DO EQUIPAMENTO NA SITUAÇÃO QUE SE ENCONTRA			NECESSÁRIA AÇÃO DE MELHORIA	

17. IMPLEMENTAÇÕES REALIZADAS NOS EQUIPAMENTOS

As adequações apresentadas no item 17 deste documento deverão ser adotadas no projeto e fabricação de todos os equipamentos que compõem o portfólio de produtos da Johnson Controls, tanto para compressores RWF II quanto para unidades PAC.

Item 12.55

As proteções foram construídas de forma a existirem durante toda a vida útil da máquina, são de material resistente, não contém pontos de agarramento ou esmagamento, são pintadas na cor amarela externamente

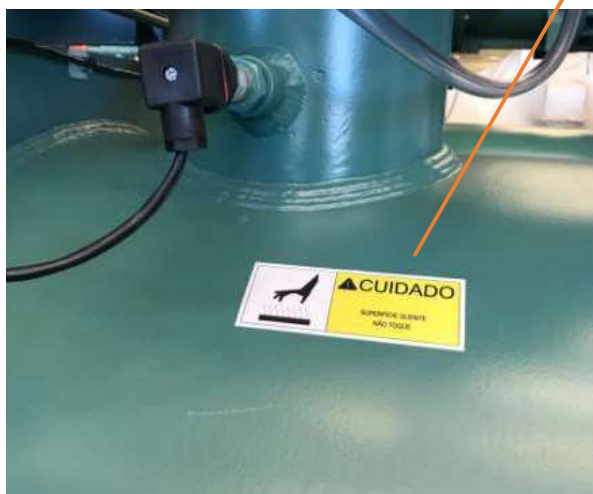

Item 12.109

É obrigatória a adoção medidas de proteção contra queimaduras, causadas pelo contato com superfícies aquecidas. Caso registre-se temperatura excedente a 80° C, providenciar proteção fixa, removível somente com o auxílio de ferramentas, de forma que envolva todas as partes quentes, evitando queimaduras por contato não intencional.

Item 12.14

As instalações elétricas de máquinas e equipamentos devem ser projetadas e mantidas de modo a prevenir, por meios seguros, os perigos de choque elétrico.

Item 10.10.1. Nas instalações de serviços deve ser adotada sinalização adequada de segurança.



Item 12.123.

PLAQUETA INDELÉVEL deve ter as seguintes informações: Razão social, CNPJ e endereço do fabricante, informação sobre tipo, modelo e capacidade, número de série ou identificação, e ano de fabricação, número de registro do fabricante/importador ou do profissional legalmente habilitado no CREA e peso da máquina ou equipamento.

18. CHECK LIST NR-12

ITEM DA NORMA	ARRANJOS FÍSICOS E INSTALAÇÕES (C)CONFORME (IC)INSTALAÇÃO DO CLIENTE (NC)NÃO CONFORME (NA)NÃO SE APLICA	
12.6 a 12.13	AS ÁREAS DE CIRCULAÇÃO SÃO DEVIDAMENTE DEMARCADAS E EM CONFORMIDADE COM AS NORMAS TÉCNICAS, OBSERVADA LARGURA DE 1,20M E CONSERVADAS SEMPRE LIMPAS E DESOBSTRUÍDAS, GARANTINDO ESPAÇO SUFICIENTE PARA MOVIMENTAÇÕES?	IC
	O PISO ONDE SE INSTALA É DE MATERIAL RESISTENTE, LIVRE DE SUBSTÂNCIAS QUE O TORNE ESCORREGADIO, É MANTIDO LIMPO E EM BOM ESTADO DE CONSERVAÇÃO?	IC
	MÁQUINAS ESTACIONÁRIAS POSSUEM PROJETO DE INSTALAÇÃO CONTEMPLANDO FIXAÇÃO, AMORTECIMENTO, NIVELAMENTO, VENTILAÇÃO, ALIMENTAÇÃO ELÉTRICA, PNEUMÁTICA E HIDRÁULICA, ATERRAMENTO E SISTEMAS DE REFRIGERAÇÃO CONFORME ORIENTAÇÕES DO FABRICANTE OU PROFISSIONAL DEVIDAMENTE CAPACITADO?	IC
	OS RODÍZIOS POSSUEM MECANISMO DE TRAVAMENTO?	NA
	ESTÃO INSTALADAS EM LOCAIS ONDE NÃO HAJA MOVIMENTAÇÃO AÉREA DE MATERIAIS SOBRE PESSOAS?	IC
ITEM DA NORMA	INSTALAÇÕES E DISPOSITIVOS ELÉTRICOS (C)CONFORME (IC)INSTALAÇÃO DO CLIENTE (NC)NÃO CONFORME (NA)NÃO SE APLICA	
12.14 a 12.23	AS INSTALAÇÕES ELÉTRICAS SÃO PROJETADAS E MANTIDAS DE FORMA A EVITAR CHOQUES, INCÊNDIOS, EXPLOSÃO OU OUTROS TIPOS DE ACIDENTES, POSSUEM ATERRAMENTO, SÃO BLINDADAS EM CASO DE EXPOSIÇÃO À UMIDADE, DISPOSTAS DE FORMA QUE NÃO TENHAM CONTATO COM PARTES MÓVEIS, CANTOS VIVOS OU MATERIAIS COMBUSTÍVEIS E CONSTRUÍDAS DE MATERIAIS INCOMBUSTÍVEIS?	C
	OS QUADROS DE ENERGIA ESTÃO TRANCADOS, POSSUEM IDENTIFICAÇÃO DE PERIGO E TENSÃO, SÃO MANTIDOS EM BOM ESTADO E LIVRES DE MATERIAIS E FERRAMENTAS, POSSUEM IDENTIFICAÇÃO DO CIRCUITO?	C
	A UTILIZAÇÃO DE CHAVE TIPO FACA, CHAVE GERAL COMO DISPOSITIVO DE PARTIDA E PARADA, PARTES ENERGIZADAS EXPOSTAS, SÃO PROIBIDAS?	NA
	BATERIAS SÃO INSTALADAS, MANTIDAS E SUBSTITUÍDAS SEGUINDO-SE ORIENTAÇÕES DOS FABRICANTES?	NA
ITEM DA NORMA	DISPOSITIVO DE PARTIDA, ACIONAMENTO E PARADA (C) CONFORME (IC)INSTALAÇÃO DO CLIENTE (NC)NÃO CONFORME (NA)NÃO SE APLICA	
12.24 a 12.37	OS DISPOSITIVOS DE PARTIDA, ACIONAMENTO E PARADA SÃO INSTALADOS DE FORMA QUE NÃO SE LOCALIZEM EM ÁREAS DE RISCO, POSSAM SER ACIONADOS EM CASO DE EMERGÊNCIA POR OUTRA PESSOA, NÃO SEJAM ACIONADOS INVOLUNTARIAMENTE, NÃO OFEREÇAM RISCOS ADICIONAIS OU QUE NÃO POSSAM SER BURLADOS?	IC
	OS COMANDOS DE PARTIDA OU ACIONAMENTO DAS MÁQUINAS POSSUEM DISPOSITIVOS QUE IMPEÇAM SEU FUNCIONAMENTO AUTOMÁTICO AO SEREM ENERGIZADAS?	C
	COMANDOS BI MANUAIS GARANTEM OCUPAÇÃO EFETIVA DAS MÃOS FORA DA ZONA DE PERIGO, POSSUEM ATUAÇÃO CONJUNTA E ESTÃO DISPOSTOS DE FORMA A DIFICULTAR QUALQUER POSSIBILIDADE DE ADULTERAÇÃO DE SUAS FUNÇÕES?	NA

	QUANDO DA UTILIZAÇÃO POR MAIS DE UMA PESSOA EXISTE COMANDO BI MANUAL PARA CADA UM DOS USUÁRIOS?	NA
	EQUIPAMENTOS DE GRANDE PROPORÇÃO TEM SINAIS SONOROS PRECEDENDO SEU FUNCIONAMENTO? OS SINAIS SÃO CONHECIDOS E DIFERENCIADOS DOS DEMAIS SINAIS SONOROS?	NA
	TODOS OS DISPOSITIVOS DE PARTIDA, ACIONAMENTO E PARADA SÃO ALIMENTADOS POR BAIXA TENSÃO (25VCA OU 60VCC)? OU FOI ADOTADA OUTRA MEDIDA CONTRA CHOQUES ELÉTRICOS? POSSUEM SISTEMA QUE PERMITE BLOQUEIO P/EVITAR O USO POR PESSOA NÃO AUTORIZADA?	C
SISTEMAS DE SEGURANÇA		
ITEM DA NORMA	(C) CONFORME (IC) INSTALAÇÃO DO CLIENTE (NC) NÃO CONFORME (NA) NÃO SE APLICA	
12.38 a 12.55	AS ZONAS DE PERIGO DAS MÁQUINAS E EQUIPAMENTOS POSSUEM SISTEMAS DE SEGURANÇA, CARACTERIZADOS POR PROTEÇÕES FIXAS.	C
	PROTEÇÕES MÓVEIS E DISPOSITIVOS DE SEGURANÇA INTERLIGADOS, QUE GARANTAM PROTEÇÃO À SAÚDE E À INTEGRIDADE FÍSICA DOS TRABALHADORES?	NA
	OS SISTEMAS DE SEGURANÇA FORAM PROJETADOS E INSTALADOS POR PROFISSIONAL LEGALMENTE HABILITADO? FORAM LEVADAS EM CONSIDERAÇÃO POSSIBILIDADES DE NEUTRALIZAÇÃO OU BURLA DOS SISTEMAS?	C
	EM CASO DE PARADA POR DEFEITOS O REARME SÓ É POSSÍVEL APÓS O RESET MANUAL DO SISTEMA OPERACIONAL?	C
	PROTEÇÕES FIXAS SÃO RETIRADAS APÓS O BLOQUEIO DO EQUIPAMENTO E AS MÓVEIS SÃO DOTADAS DE INTER TRAVAMENTO ELÉTRICO?	NA
	AS PROTEÇÕES ELIMINAM ACESSO ÀS ZONAS DE PERIGO? AO SEREM RETIRADAS AS PROTEÇÕES COM INTER TRAVAMENTO AS ZONAS DE RISCO SÃO PARALISADAS AUTOMATICAMENTE?	NA
	AS PROTEÇÕES FORAM CONSTRUÍDAS DE FORMA A EXISTIREM DURANTE TODA A VIDA ÚTIL DA MÁQUINA? SÃO DE MATERIAL RESISTENTE? NÃO CONTÉM PONTOS DE AGARRAMENTO OU ESMAGAMENTO? SÃO PINTADAS NA COR AMARELA EXTERNAMENTE E LARANJA INTERNAMENTE?	C
	POSSUI MANUAL EM PORTUGUÊS (DOCUMENTAÇÃO TÉCNICA) OU A DEVIDA ART - ANOTAÇÃO DE RESPONSABILIDADE TÉCNICA, QUANDO A DOCUMENTAÇÃO TÉCNICA NÃO ESTÁ DISPONÍVEL?	C
DISPOSITIVOS DE PARADA DE EMERGÊNCIA		
ITEM DA NORMA	(C) CONFORME (IC) INSTALAÇÃO DO CLIENTE (NC) NÃO CONFORME (NA) NÃO SE APLICA	
12.56 a 12.63	POSSUI DISPOSITIVOS DE PARADA DE EMERGÊNCIA E ESTES NÃO SÃO UTILIZADOS COMO DISPOSITIVOS DE ACIONAMENTO E PARADA? (EXCETO AUTO PROPELIDOS)	C
	OS DISPOSITIVOS DE PARADA DE EMERGÊNCIA SÃO FACILMENTE IDENTIFICADOS, LOCALIZADOS AO ALCANCE DO OPERADOR? PODEM SER FACILMENTE ACESSADOS POR OUTRAS PESSOAS? SÃO MANTIDOS PERMANENTEMENTE DESOBRSTUÍDOS? SÃO TESTADOS PERIODICAMENTE?	C
MEIOS DE ACESSO PERMANENTES		
ITEM DA NORMA	(C) CONFORME (IC) INSTALAÇÃO DO CLIENTE (NC) NÃO CONFORME (NA) NÃO SE APLICA	
12.64	POSSUI ACESSOS PERMANENTEMENTE FIXADOS E SEGUROS A TODOS OS SEUS PONTOS DE OPERAÇÃO, ABASTECIMENTO, INSERÇÃO DE MATÉRIAS PRIMAS E	NA

	RETIRADA DE PRODUTOS TRABALHADOS, PREPARAÇÃO, MANUTENÇÃO E INTERVENÇÃO CONSTANTE.	
	NA AUSÊNCIA DE MEIOS DE ACESSO COMO ELEVADORES, RAMPAS, PASSARELAS, PLATAFORMAS OU ESCADAS DE DEGRAUS EXISTE ESCADA TIPO MARINHEIRO?	NA
	PLATAFORMAS DE TRABALHO FIXAS E ESTÁVEIS ESTÃO DISPONÍVEIS? PLATAFORMAS MÓVEIS E ELEVATÓRIAS SÃO DISPONIBILIZADAS CASO NÃO EXISTA PLATAFORMA FIXA?	IC
	AS PASSARELAS, PLATAFORMAS, RAMPAS E ESCADAS DE DEGRAUS E GUARDA-CORPOS PROPICIAM CONDIÇÕES SEGURAS DE TRABALHO, CIRCULAÇÃO, MOVIMENTAÇÃO E MANUSEIO DE MATERIAIS E SÃO CONSTRUÍDAS CONFORME NORMAS ESPECÍFICAS?	NA
COMPONENTES PRESSURIZADOS		
ITEM DA NORMA	(C) CONFORME (IC) INSTALAÇÃO DO CLIENTE (NC) NÃO CONFORME (NA) NÃO SE APLICA	
12.77 a 12.84	MANGUEIRAS, CIRCUITOS HIDRÁULICOS E PNEUMÁTICOS E TUBULAÇÕES ESTÃO PROTEGIDOS CONTRA IMPACTOS ACIDENTAIS E DISPOSTOS DE FORMA QUE UMA RUPTURA NÃO CAUSE ACIDENTES POR IMPACTO CONTRA PESSOAS?	NA
	AS MANGUEIRAS UTILIZADAS TÊM INFORMAÇÕES SOBRE A PRESSÃO MÁXIMA DE TRABALHO?	NA
	OS MANÔMETROS INFORMAM A PRESSÃO MÁXIMA DE TRABALHO? A PRESSÃO MÁXIMA DE TRABALHO ADMISSÍVEL NOS CIRCUITOS NÃO POSSA SER EXCEDIDA;	C
	MONTAGEM E DESMONTAGEM DE PNEUS SÃO EXECUTADAS SEGUINDO REGRAS ESPECÍFICAS? O ENCHIMENTO DE PNEUS CUJOS AROS POSSAM SER PROJETADOS SÃO REALIZADOS EM GAIOLAS ESPECÍFICAS?	NA
TRANSPORTADORES DE MATERIAIS		
ITEM DA NORMA	(C) CONFORME (IC) INSTALAÇÃO DO CLIENTE (NC) NÃO CONFORME (NA) NÃO SE APLICA	
12.94 a 12.105	OS TRANSPORTADORES CONTÍNUOS LOCALIZADOS A MENOS DE 2,70M DO PISO POSSUEM PROTEÇÃO EFETIVA CONTRA CONTATO ACIDENTAL? POSSUEM SISTEMA DE PARADA DE EMERGÊNCIA EM CASO DE DESALINHAMENTO, EXCESSO DE CARGA OU CONTATO ACIDENTAL?	NA
	EXISTEM PASSARELAS ESPECÍFICAS PARA PASSAGEM DE PESSOAS E ACESSO EM CASO DE MANUTENÇÕES? A PERMANÊNCIA DE PESSOAS SOB OS TRANSPORTADORES É PROIBIDA? A PASSAGEM SOB TRANSPORTADORES É FEITA EM ÁREAS PROTEGIDAS?	NA
ASPECTOS ERGONÔMICOS		
ITEM DA NORMA	(C) CONFORME (IC) INSTALAÇÃO DO CLIENTE (NC) NÃO CONFORME (NA) NÃO SE APLICA	
12.94 a 12.105	FOI DESENVOLVIDO ESTUDO ERGONÔMICO QUANDO A MÁQUINA OU EQUIPAMENTO É POSTO DE TRABALHO?	IC
	APOIO PARA OS PÉS, ILUMINAÇÃO, CONDIÇÕES DOS ASSENTOS, O RITMO DE TRABALHO, CONDIÇÕES ANTROPOMÉTRICAS FORAM CONSIDERADOS NO ESTUDO ERGONÔMICO?	IC

ITEM DA NORMA	RISCOS ADICIONAIS (C) CONFORME (IC) INSTALAÇÃO DO CLIENTE (NC) NÃO CONFORME (NA) NÃO SE APLICA	
12.106 a 12.110	TODOS OS RISCOS ADICIONAIS COMO CALOR, RUÍDO, POEIRA, GASES, VIBRAÇÕES, RADIAÇÕES, SUBSTÂNCIAS QUÍMICAS, ETC, FORAM CONSIDERADOS NA AVALIAÇÃO DE RISCOS DAS ATIVIDADES ENVOLVENDO MÁQUINAS E EQUIPAMENTOS?	C
ITEM DA NORMA	MANUTENÇÃO, INSPEÇÃO, PREPARAÇÃO, AJUSTES E REPAROS (C) CONFORME (IC) INSTALAÇÃO DO CLIENTE (NC) NÃO CONFORME (NA) NÃO SE APLICA	
12.111 a 12.115	EXISTE PLANO DE MANUTENÇÃO APLICADO AO TIPO DE MÁQUINA EM ESTUDO, CONTEMPLANDO ITENS CRÍTICOS, PERIODICIDADE, RESULTADOS DAS INSPEÇÕES, TIPOS E TÉCNICAS DE INSPEÇÕES, ENSAIOS, ETC?	IC
	EXISTE INSPEÇÃO PRÉ-TRABALHO, ITENS CRÍTICOS QUE CAUSAM A PARADA IMEDIATA SÃO CONHECIDOS, MANUTENÇÃO, LIMPEZA E AJUSTES SOMENTE SÃO EXECUTADOS APÓS BLOQUEIO E ISOLAMENTO DE ENERGIA?	IC
ITEM DA NORMA	SINALIZAÇÃO (C) CONFORME (IC) INSTALAÇÃO DO CLIENTE (NC) NÃO CONFORME (NA) NÃO SE APLICA	
12.116 a 12.124	EXISTE SINALIZAÇÃO DE ADVERTÊNCIA QUANTO AOS RISCOS DE PARTES MÓVEIS, ENERGIZADAS, QUENTES, ETC?	C
	PLACAS DE INFORMAÇÕES QUANTO AO FABRICANTE, CARACTERÍSTICAS DO EQUIPAMENTO, CLASSE, ETC ESTÃO DISPONÍVEIS (OBRIGATÓRIO PARA MÁQUINAS FABRICADAS E IMPORTADAS A PARTIR DE 12/2010)	C
ITEM DA NORMA	MANUAIS (C) CONFORME (IC) INSTALAÇÃO DO CLIENTE (NC) NÃO CONFORME (NA) NÃO SE APLICA	
12.125 a 12.129	A MÁQUINA OU EQUIPAMENTO É DOTADO DE MANUAL EM PORTUGUÊS CONTENDO TODAS AS INFORMAÇÕES REFERENTES A CARACTERÍSTICAS TÉCNICAS, MANUTENÇÃO E OPERAÇÃO?	C
ITEM DA NORMA	PROCEDIMENTOS DE TRABALHO E SEGURANÇA (C) CONFORME (IC) INSTALAÇÃO DO CLIENTE (NC) NÃO CONFORME (NA) NÃO SE APLICA	
12.130 a 12.132	PROCEDIMENTOS DE TRABALHO E SEGURANÇA ESTÁ DISPONÍVEL, A VERSÃO DISPONIBILIZADA É A MAIS ATUAL E TODOS OS ENVOLVIDOS EM OPERAÇÃO E MANUTENÇÃO FORAM TREINADOS NESTA VERSÃO?	IC
ITEM DA NORMA	PROJETO, FABRICAÇÃO, IMPORTAÇÃO, VENDA, LOCAÇÃO, CESSÃO, EXPOSIÇÃO E UTILIZAÇÃO (C) CONFORME (IC) INSTALAÇÃO DO CLIENTE (NC) NÃO CONFORME (NA) NÃO SE APLICA	
12.133 a 12.134	O PROJETO LEVOU EM CONTA A SEGURANÇA INTRÍNSECA DA MÁQUINA OU EQUIPAMENTO DURANTE AS FASES DE CONSTRUÇÃO, TRANSPORTE, MONTAGEM, INSTALAÇÃO, AJUSTE, OPERAÇÃO, LIMPEZA, MANUTENÇÃO, INSPEÇÃO, DESATIVAÇÃO, DESMONTE E SUCATEAMENTO POR MEIO DAS REFERÊNCIAS TÉCNICAS INDICADAS NESTA NORMA, A SEREM OBSERVADAS PARA GARANTIR A SAÚDE E A INTEGRIDADE FÍSICA DOS TRABALHADORES?	C

ITEM DA NORMA	CAPACITAÇÃO (C)CONFORME (IC)INSTALAÇÃO DO CLIENTE (NC)NÃO CONFORME (NA)NÃO SE APLICA	
12.135 a 12.147	FOI APRESENTADO CERTIFICADO DE CURSO DE CAPACITAÇÃO E É ESPECÍFICO PARA O TIPO MÁQUINA OU EQUIPAMENTO E INCLUI AS SUAS CARACTERÍSTICAS, RISCOS OPERACIONAIS, DISPOSITIVOS DE SEGURANÇA, DEMONSTRAÇÃO PRÁTICA DOS RISCOS E DISPOSITIVOS DE SEGURANÇA?	IC
ITEM DA NORMA	OUTROS REQUISITOS ESPECÍFICOS DE SEGURANÇA (C)CONFORME (IC)INSTALAÇÃO DO CLIENTE (NC)NÃO CONFORME (NA)NÃO SE APLICA	
12.148 a 12.152	FERRAMENTAS E MATERIAIS UTILIZADOS EM MANUTENÇÃO SÃO PADRONIZADOS? É PROIBIDO O USO DE FERRAMENTAS E DISPOSITIVOS DE FABRICAÇÃO CASEIRA? EXISTE SISTEMÁTICA DE INSPEÇÃO PARA ESTES ITENS?	IC
	OS SISTEMAS DE REBOQUE E ENGATE SÃO PADRONIZADOS QUANDO DISPONÍVEIS NAS MÁQUINAS E EQUIPAMENTOS? O REBOQUE COM CORDAS OU CABOS DE AÇO É PROIBIDO? SOMENTE CAMBÃO É PERMITIDO PARA REBOQUE?	NA
ITEM DA NORMA	DISPOSIÇÕES FINAIS (C)CONFORME (IC)INSTALAÇÃO DO CLIENTE (NC)NÃO CONFORME (NA)NÃO SE APLICA	
12.153 a 12.157	ESTÁ INCLUÍDO NO INVENTÁRIO ATUALIZADO DAS MÁQUINAS E EQUIPAMENTOS COM IDENTIFICAÇÃO POR TIPO, CAPACIDADE, SISTEMAS DE SEGURANÇA E LOCALIZAÇÃO EM PLANTA BAIXA, ELABORADO POR PROFISSIONAL QUALIFICADO OU LEGALMENTE HABILITADO? ESTÁ DISPONÍVEL PARA CONSULTA INTERNA E DE ÓRGÃOS EXTERNOS?	IC
<p>C: Abreviatura adotada para identificar "CONFORMIDADE" para cada item avaliado, quando este se encontra em conformidade e atendendo plenamente os requisitos obrigatórios da norma regulamentadora NR-12.</p> <p>NC: Abreviatura adotada para identificar "NÃO CONFORMIDADE" para cada item avaliado, quando este não está atendendo plenamente os requisitos da norma regulamentadora NR-12.</p> <p>IC: Abreviatura adotada para identificar "INSTALAÇÃO DO CLIENTE" significa reponsabilidade do cliente instalar para atender plenamente os requisitos da norma regulamentadora NR-12.</p> <p>NA: NÃO SE APLICA</p>		

19. REFERÊNCIAS TÉCNICAS SOBRE AS NORMAS DE SEGURANÇA

Conforme necessidade observadas, a Protect Engenharia indica através desta proposta as proteções utilizando os dispositivos de segurança citados abaixo. Estas sugestões vêm atender as seguintes normas de segurança:

NR12 Norma Regulamentadora 12

NBR Norma Brasileira de Referência

ABNT NBR ISO 12100:2013 -Segurança de máquinas - Princípios gerais de projeto - Apreciação e redução de riscos

ABNT NBR 5410:2004 -Versão Corrigida:2008 - Instalações elétricas de baixa tensão

ABNT NBR NM ISO 13852:2003 -Segurança de máquinas - Distâncias de segurança para impedir o acesso a zonas de perigo pelos membros superiores

ABNT NBR NM ISO 13853:2003 -Segurança de máquinas - Distâncias de segurança para impedir o acesso a zonas de perigo pelos membros inferiores

ABNT NBR NM ISO 13854:2003 -Segurança de máquinas - Folgas mínimas para evitar esmagamento de partes do corpo humano

ABNT NBR ISO 13855:2013 -Segurança de máquinas - Posicionamento dos equipamentos de proteção com referência à aproximação de partes do corpo humano

ABNT NBR 13759:1996 -Segurança de máquinas - Equipamentos de parada de emergência - Aspectos funcionais - Princípios para projeto

ABNT NBR 14152:1998 -Segurança de máquinas - Dispositivos de comando bimanuais - Aspectos funcionais e princípios para projeto

ABNT NBR 14153:2013 -Segurança de máquinas - Partes de sistemas de comando relacionados à segurança - Princípios gerais para projeto

ABNT NBR 14154:1998 -Segurança de máquinas - Prevenção de partida inesperada

ABNT NBR 13970:1997 -Segurança de máquinas - Temperatura de superfícies acessíveis - Dados ergonômicos para estabelecer os valores limites de temperatura de superfícies aquecidas

ABNT NBR NM 272:2002 -Segurança de máquinas - Proteções - Requisitos gerais para o projeto e construção de proteções fixas e móveis

ABNT NBR NM 273:2002 -Segurança de máquinas - Dispositivos de intertravamento associados a proteções - Princípios para projeto e seleção

ABNT NBR IEC 60439-1:2003 -Conjuntos de manobras e controle de baixa tensão - Parte 1: Conjuntos com ensaio de tipo totalmente testados (TTA) e conjuntos com ensaio de tipo parcialmente testados (PTTA)

ABNT NBR IEC 60439-2:2003 -Conjuntos de manobras e controle de baixa tensão - Parte 2: Requisitos particulares para linhas pré-fabricadas (sistemas de barramentos blindados)

ABNT NBR IEC 60439-3:2003 -Conjuntos de manobras e controle de baixa tensão - Parte 3: Requisitos particulares para montagem de acessórios de baixa tensão destinados a instalação em locais acessíveis a pessoas não qualificadas durante sua utilização - Quadros de distribuição

ABNT NBR IEC 60529:2017 - Grau de proteção providos de invólucros (Códigos IP)

20. CONSIDERAÇÕES FINAIS

O equipamento não deve operar sem suas devidas proteções mecânicas.

A instalação, manutenção e operação dos equipamentos aqui citados deverão obedecer às práticas documentadas no manual do fabricante.

Todos os equipamentos fabricados deverão possuir as implementações de segurança recomendadas neste documento.

21. CONCLUSÃO

Com base nos manuais de fabricação, operação e manutenção do portfólio de produtos, no acompanhamento de fabricação das máquinas e tendo como base todas as implementações de segurança apresentadas neste documento, concluímos que, o Portfólio de Produtos apresentado pela empresa contratante, Johnson Controls BE do Brasil, unidade de Sorocaba, foi adequado para cumprimento da legislação vigente e está em conformidade com a norma regulamentadora N°12, atendendo todos os seus requisitos.

Foi constatado também que as máquinas que compõe o portfólio de produtos apresentado oferecem risco muito baixo para segurança e saúde (HRN 0,2) e (ABNT) análise de riscos - ABNT NBR 14.153 Categoria B (S1) leve (reversível).

Sem mais, o portfólio de produtos das unidades RWF II e PAC acima descrito, encontra-se aprovado e validado por este profissional legalmente habilitado e registrado no conselho de classe vigente.

Sorocaba, 28 de maio de 2019



Engº Renato Cristi
CREA: 5069876228



Anotação de Responsabilidade Técnica - ART
Lei nº 6.496, de 7 de dezembro de 1977

Conselho Regional de Engenharia e Agronomia do Estado de São Paulo

ART de Obra ou Serviço
28027230190668965

1. Responsável Técnico

RENATO CRISTI

Título Profissional: Engenheiro Mecânico, Engenheiro de Segurança do Trabalho

RNP: 2615858777

Registro: 5069876228-SP

Empresa Contratada: **RENATO CRISTI ME**

Registro: 2199540-SP

2. Dados do Contrato

Contratante: **JOHNSON CONTROLS BE DO BRASIL LTDA**

CPF/CNPJ: 01.092.686/0023-66

Endereço: **Avenida INDEPENDÊNCIA**

Nº: 2757

Complemento:

Bairro: **IPORANGA**

Cidade: **Sorocaba**

UF: **SP**

CEP: 18087-101

Contrato:

Celebrado em: **29/03/2019**

Vinculada à Art nº:

Valor: **R\$ 18.000,00**

Tipo de Contratante: **Pessoa Jurídica de Direito Privado**

Ação Institucional:

3. Dados da Obra Serviço

Endereço: **Avenida INDEPENDÊNCIA**

Nº: 2757

Complemento:

Bairro: **IPORANGA**

Cidade: **Sorocaba**

UF: **SP**

CEP: 18087-101

Data de Início: **30/04/2019**

Previsão de Término: **30/07/2019**

Coordenadas Geográficas:

Finalidade:

Código:

CPF/CNPJ:

4. Atividade Técnica

			Quantidade	Unidade
Consultoria				
1	Laudo	Análise de Risco	2,00000	unidade

Após a conclusão das atividades técnicas o profissional deverá proceder a baixa desta ART

5. Observações

LAUDO DE CONFORMIDADE PARA PORTFÓLIO DE PRODUTOS DE REFRIGERAÇÃO INDUSTRIAL DA EMPRESA JOHNSON CONTROLS BE.
UNIDADE COM COMPRESSOR PARAFUSO MODELO RWF II 100 ATÉ RWF II 1080
E
UNIDADE DE REFRIGERAÇÃO POR AMÔNIA MODELO PAC 100 ATÉ PAC 1080.

6. Declarações

Acessibilidade: Declaro que as regras de acessibilidade previstas nas normas técnicas da ABNT, na legislação específica e no Decreto nº 5.296, de 2 de dezembro de 2004, não se aplicam às atividades profissionais acima relacionadas.

Renato Cristi
Engenheiro Mecânico
CREA - 5069876228

7. Entidade de Classe

73 - SOROCABA - ASSOCIAÇÃO DOS ENGENHEIROS E ARQUITETOS DE SOROCABA

8. Assinaturas

Declaro serem verdadeiras as informações acima

Sorocaba 30 de Maio de 2019
Local data

RENATO CRISTI - CPF: 295.251.738-01

JOHNSON CONTROLS BE DO BRASIL LTDA - CPF/CNPJ: 01.092.686/0023-66

9. Informações

- A presente ART encontra-se devidamente quitada conforme dados constantes no rodapé-versão do sistema, certificada pelo Nosso Número.

- A autenticidade deste documento pode ser verificada no site www.creasp.org.br ou www.confea.org.br

- A guarda da via assinada da ART será de responsabilidade do profissional e do contratante com o objetivo de documentar o vínculo contratual.

www.creasp.org.br
Tel: 0800 17 18 11
E-mail: acessar link Fale Conosco do site acima



Valor ART R\$ 226,50
Registrada em: 29/05/2019
Impresso em: 30/05/2019 08:12:58

Valor Pago R\$ 226,50

Nosso Numero: 28027230190668966 Versão do sistema



ELABORADO POR / PREPARED BY:

Sueli Moraes
Quality Analyst
Building Technology & Solutions Latin America
Johnson Controls

+55 15 3415-3119
sueli.vieira-ext@jci.com
www.johnsoncontrols.com.br

Johnson Controls
Av. Independência 2757 – Éden - Sorocaba/SP

MANUAL DE OPERAÇÃO DE VASO DE PRESSÃO

VP007-SEPARADOR DE ÓLEO 01

MARFRIG GLOBAL FOODS – BATAGUASSU- MS

2025

SUMÁRIO

APRESENTAÇÃO	03
RESPONSABILIDADES DO FABRICANTE	04
RESPONSABILIDADE DO PROPRIETÁRIO E OU OPERADOR RESPONSÁVEL	05
OBSERVAÇÕES DE OPERAÇÃO	06
INFORMAÇÕES DO FLUIDO UTILIZADO NO SISTEMA	07
INFORMAÇÕES GERAIS	08
SEGURANÇA CONSIDERAÇÕES	09
SIMBOLOGIA DE SEGURANÇA	10
SIMBOLOGIA DE PROIBIÇÃO	12
SIMBOLOGIA DE OBRIGATORIEDADE	13
EMERGÊNCIAS	14
OBSERVAÇÕES DE EMERGÊNCIAS	15
CONDICIONAMENTO OPERACIONAL	16
OPERAÇÃO INADEQUADA	17
PERIGOS TÉRMICOS RESIDUAIS	19
PERIGOS RESIDUAIS COM REFRIGERANTE	20
VASO DE PRESSÃO (SEPARADOR DE ÓLEO 01)	21
CARACTERÍSTICAS DA AMÔNIA ANIDRA R717	23
SEGURANÇA OPERACIONAL DO VASOS DE PRESSÃO	27
RECOMENDAÇÕES PARA SISTEMAS DE REFRIGERAÇÃO POR AMÔNIA	34

APRESENTAÇÃO

Utilizado como Separador de óleo, e vasos de pressão em geral, têm uma série de benefícios, entre elas:

- Fabricados conforme norma de projeto ASME VIII Divisão I e norma regulamentadora NR-13;
- Processos de solda de alta eficiência e alta qualidade por arco submerso (tampas e corpo);
- Materiais certificados e com rastreabilidade total;
- Inspeções de qualidade e testes não-destrutivos;
- Customizações de acordo a necessidade e aplicação;
- Montagens de sistemas completos em fábrica (bombas de recirculação, trocadores a placas, acessórios em geral).

O manual de recomendações para projeto, operação, manutenção e comissionamento, entre outras documentações deverá estar sempre disponível para referência. Em caso de dúvida, ou necessidade em reposição de peças, favor contatar a área comercial e qualidade da fabricante do vaso conforme informada em prontuário e placa de identificação, que fará o possível para atender a sua necessidade de maneira rápida e eficaz.

RESPONSABILIDADES DO FABRICANTE

As observações fornecidas nestas instruções para a manutenção da segurança funcional do equipamento, evitando possíveis perigos durante o transporte, montagem e instalação, partida e operação, e com as atividades de manutenção (limpeza, assistência técnica e reparos) se referem somente à unidade, e não se aplicam a outras séries de equipamentos e ou equipamentos de outros fabricantes.

Os materiais de fabricação são configurados de tal forma que resistam à tensão mecânica, térmica e química previsível, e sejam resistentes aos fluídos de trabalho e ou as misturas de fluídos de trabalho/óleo de refrigeração previstos no projeto inicial.

As partes soldadas que transportam os fluídos de trabalho (tubos centrais, distribuidores e coletores) estão projetados de modo que eles permaneçam soldados mesmo com a tensão mecânica, térmica e química previsível, e resistem à pressão máxima de operação admissível (PMTA).

Materiais, espessura da parede dos tubos (centrais, distribuidores e coletores), resistência à tração, resistência à corrosão, processo e testes são adequados para os fluídos de trabalho definidos no projeto inicial e resistem às possíveis pressões, tensões e temperaturas que podem ocorrer.

RESPONSABILIDADES DO PROPRIETÁRIO E/OU DO OPERADOR RESPONSÁVEL

O proprietário e ou o operador responsável deve verificar se o pessoal operacional está treinado e qualificado o suficiente para operar, monitorar e realizar assistência técnica no equipamento/ sistema. Antes da partida do sistema, o responsável deve verificar se a equipe está suficientemente informada com relação à documentação do equipamento (instruções de operação), configuração do sistema, monitoramento, operação e assistência técnica, medidas de segurança, e com relação às propriedades e manuseio dos fluidos de trabalho a serem usados.

O responsável deve se certificar de que, ao operar, monitorar e realizar manutenção no sistema, os fluidos de trabalho não deverão ser alterados dos dados especificados nos documentos de projeto relacionados ao pedido.

Planejamento e preparação das medidas de emergência: a fim de evitar danos por transtornos operacionais, deve ser haver um sistema de avisos nas instalações. Prepare medidas de emergência que evitem danos para pessoas e equipamentos, caso ocorram falhas. A responsabilidade permanece com o proprietário e ou o operador responsável do equipamento, se o equipamento for usado por terceiros, a menos que haja um acordo para compartilhamento da responsabilidade.

OBSERVAÇÕES DE OPERAÇÃO

Estas instruções de operação se aplicam para todos os modelos de vasos para operação de acordo com os fluidos de trabalho, pressões e temperaturas especificadas nos documentos de projeto relacionados ao projeto.

Equipamento: Separador de óleo 01

Tipo de Equipamento: Horizontal

Modelo: HOS 36

Fabricante: JOHNSON CONTROLS

Fluido Principal: Amônia

Nº de Série: 367259

Categoria: II

Classe do Fluido: A

Grupo Potencial de Risco: 3

Pressão Máxima de Trabalho Admissível: 21,41 kgf/cm²

Pressão de teste hidrostático: 24,00 kgf/cm²

Volume Interno: 2,409 m³

Ano de Fabricação: 2021

Código da inspeção: VP007 INDUSTRIALIZADOS

Código de Projeto: Asme VIII Divisão 01 – Ed 2019

Material do Costado (Adotado para cálculo): ASTM SA 516 Grau 70

Material dos Tampos (Adotado para cálculo): ASTM SA 516 Grau 70

Diâmetro Interno: 750 mm

Comprimento do Corpo Cilíndrico: 3520 mm

Comprimento Total do Equipamento: 4020 mm

Massa Vazio: 973 kg

Espessura nominal do costado: 12,72 mm 1/2"

Espessura nominal dos tampos: 12,72 mm 1/2"

INFORMAÇÕES SOBRE O FLUIDO UTILIZADO NO SISTEMA

Fluído	Amônia Anidra
Aparência e Odor	Gás comprimido liquefeito, incolor com odor característico
Forma Molecular	NH ₃
Ponto de Ebulição	33,35°C
Ponto de Fusão	77,70°C
Peso Molecular	17,00 g/mol
Densidade	0,682 g/cm ³ (20°C)
Temperatura de auto ignição	651°C
Ponto de fulgor	-
LSE (Limite Superior de Explosividade)	25% (2500 PPM)
LIE (Limite Inferior de Explosividade)	16% (1600 PPM)
Limite de Tolerância	14 mg/m ³ (20 PPM)
IPVS	300 PPM
Solubilidade em água.	1 vol. de água dissolve 1300 volume do gás-Alta
Absorção de calor	1,1007 cal/g°C - Alta

INFORMAÇÕES GERAIS

Os vasos de pressão são projetados para fornecer a melhor eficiência e uma prolongada vida útil quando instalados, operados e cuidados adequadamente.

Portanto, é altamente recomendado que uma programação de manutenção abrangente seja desenvolvida e realizada com uma frequência regular predeterminada.

Este manual irá auxiliar o proprietário – operador a desenvolver tal programação.

Este equipamento é relativamente complicado e a instalação, operação, manutenção e assistência devem ser realizadas apenas por pessoal adequado e qualificado para a realização destas funções. Estas pessoas devem também estar familiarizadas em cumprir com todas as normas e regulamentos governamentais aplicáveis, pertencentes às funções.

O tipo de fluido refrigerante e o método de alimentação para o vaso de pressão devem estar em conformidade com a indicação dos desenhos fornecidos e/ou com a placa de identificação da unidade.

As pressões de operação do projeto, como indicado na placa de identificação, nunca podem ser excedidas!

Vasos de pressão e todos os sistemas de tubulação devem ser corretamente evacuados antes de carregar o sistema com fluido refrigerante, para assegurar a retirada completa de umidade e de não condensáveis de todo circuito de refrigeração.

O não cumprimento de qualquer um destes requisitos pode resultar em sérios danos ao equipamento e/ou à propriedade onde ele está instalado, assim como em ferimento e/ou morte das pessoas presentes no local específico.

SEGURANÇA – CONSIDERAÇÕES



Aborda uma situação perigosa que, se encontrado, pode resultar em morte ou ferimentos graves.



Aborda uma situação ou instrução que deverá ser seguida rigorosamente para não resultar em danos irreparáveis ao equipamento.



Aborda uma situação de risco aos operadores ou que poderá causar danos ao equipamento.



Indica instruções que dizem respeito ao funcionamento do equipamento de segurança. O não cumprimento dessas instruções pode resultar em danos ao equipamento.

SIMBOLOGIA DE SEGURANÇA



Aviso



Alerta contra ferimento nas mãos. As mãos ou dedos podem ser esmagados, puxados ou feridos de outra maneira com a não conformidade.



Alerta contra superfícies quentes. A temperatura está acima de +45 °C (coagulação proteica) e pode causar queimaduras.



Alerta contra o frio. A temperatura está abaixo de 0 °C e pode causar ulceração de frio.



Alerta contra tensões elétricas perigosas. Perigo de choque elétrico se as peças que transportam tensão forem tocadas.



Alerta contra substâncias potencialmente explosivas no ponto de indicação. Uso de fontes de ignição podem causar explosões no ponto de indicação.



Alerta contra substâncias com risco de incêndio no ponto de indicação. Uso de fontes de ignição pode causar incêndios no ponto de indicação.



Alerta contra substâncias corrosivas. Os contatos com substâncias corrosivas podem causar ferimentos, especialmente com os olhos.



Alerta contra substâncias prejudiciais à saúde ou irritantes no ponto de indicação. O contato com substâncias inalantes prejudiciais à saúde ou irritantes pode causar ferimentos ou danos à saúde.



Alerta contra substâncias tóxicas no ponto de indicação. O contato com substâncias inalantes tóxicas pode causar ferimentos ou danos à saúde.

SIMBOLOGIA DE PROIBIÇÃO



Proibido fontes de ignição ou propagação de chamas. Fontes de ignição devem ser mantidas distantes e não devem ser geradas.



Não fume. É proibido fumar.

SIMBOLOGIA DE OBRIGATORIEDADE



Use proteção para os olhos. Proteção para os olhos: Use óculos de proteção ou proteção facial.



Use proteção para as mãos. Devem ser usadas luvas protetoras contra perigos mecânicos e químicos.



Use proteção respiratória. Os aparelhos de respiração devem ser adequados para o fluido de trabalho usado.

O aparelho de respiração deve consistir de:

- Pelo menos dois dispositivos respiratórios independentes (aparelho de respiração autônoma);
- Para amônia: um aparelho de respiração adicional com filtro (máscara total) ou um aparelho de respiração independente (autônomo);



Use roupa protetora. As roupas protetoras individuais devem ser adequadas para o fluido de trabalho usado e para baixas temperaturas, e ter boas propriedades de isolamento do calor.



Ativar antes do trabalho. Ative o sistema elétrico e proteja contra nova comutação antes de ligar a instalação, realizar trabalhos de manutenção e reparos.

EMERGÊNCIAS

Perigo de ferimentos e danos à propriedade.

O equipamento poderá conter amônia como líquido refrigerante (NH₃).

A amônia é uma substância potencialmente explosiva e com risco de incêndio. Se transportadas de forma não intencional nos resíduos de óleo e transportadas de forma não intencional no refrigerante, ela pode entrar em combustão. Uma explosão pode causar graves ferimentos e perda de membros.

A amônia é um gás corrosivo, tóxico e irritante. Uma concentração de amônia de 0,2 vol% (20ppm) no ar ambiente ou uma longa permanência em um ar ambiente contendo amônia pode ser uma ameaça à vida ou fatal.

Medidas e procedimentos de segurança.

- Com grandes fugas de refrigerante inesperadas,
- Deixe a sala de operação imediatamente e ative o comutador de PARADA de emergência em um lugar seguro;
- Ative o dispositivo de alarme de refrigerante (concentração de refrigerante);
- Tenha pessoal experiente, treinado com roupas protetoras prescritas para realizar todas as medidas de proteção e outras medidas necessárias;
- Use proteção respiratória;
- Use um aparelho de respiração que não dependa do ar da sala durante o trabalho de manutenção com altas concentrações de refrigerante no ar da sala;
- Verifique se a sala de operação está bem ventilada;
- Desvie o vapor e o líquido de refrigerante que escaparem com segurança;

Instruções sobre como tratar de ferimentos:

- Chame um médico de emergência imediatamente
- Alguns refrigerantes podem causar ferimentos corrosivos na pele e nos olhos;
- A vítima deve manter o aparelho de respiração até aviso em contrário, a fim de evitar a inalação de vapores da vestimenta contaminada com amônia;
- Lave a vítima de cinco a quinze minutos com água.
- Remova a vestimenta cuidadosamente durante o banho.
- O banho deve ser com água morna tanto quanto possível, a fim de evitar um choque térmico.
- Se disponível, use um chuveiro de emergência; do contrário, use uma mangueira de água.

OBSERVAÇÕES DE EMERGÊNCIAS

O equipamento deve ser colocado em funcionamento, operado, receber manutenção e reparos por pessoal treinado, experiente e qualificado.

As pessoas que são responsáveis pela operação, manutenção, reparos e avaliação dos sistemas e seus componentes devem ter o treinamento e possuir conhecimento especializado necessário para que o seu trabalho seja qualificado.

Qualificado ou especializado significa a capacidade de realizar, de forma satisfatória, as atividades necessárias para a operação, manutenção, reparos e avaliação dos sistemas de refrigeração e seus componentes;

O equipamento poderá ser operado por pessoal operacional que não tenha conhecimento e experiência específica de engenharia de refrigeração, com relação ao modo de operação, a operação e o monitoramento diário deste sistema.

Este pessoal operacional não poderá fazer nenhuma intervenção ou configuração no sistema;

Alterações na unidade com as quais o fabricante tenha autorizado primeiro por escrito, só poderão ser realizadas pelo pessoal treinado e qualificado.

CONDICIONAMENTO OPERACIONAL

O equipamento é um componente de um sistema de refrigeração.

O objetivo destas instruções de operação, como parte do manual de instruções de operação (do qual fazem parte estas instruções de operação), é reduzir ao mínimo os perigos às pessoas, à propriedade e ao meio ambiente da unidade, e do fluido de trabalho usado.

Estes perigos são relacionados essencialmente às propriedades físicas e químicas do fluido de trabalho e com as pressões e temperaturas que ocorrem nos componentes que transportam o fluido de trabalho no equipamento.

Para conhecimento dos perigos residuais dos refrigerantes é impreterível o conhecimento das FISPQ dos compostos (Ficha de Informação de Segurança de Produtos Químicos) fornecidas pelos fabricantes de refrigerante;

- O equipamento deve ser usado somente de acordo com o uso pretendido adequado. O operador deve se certificar de que, ao operar, monitorar e realizar manutenção no sistema, o fluido de trabalho não deverá se desviar dos dados especificados nos documentos de projeto relacionados ao pedido;
- O operador deve verificar se as medidas de manutenção estão sendo realizadas de acordo com o manual de instruções de operação do sistema;

• Não ultrapasse a PMTA informada na placa de identificação e especificada nos documentos de projeto relacionados ao pedido.

Os Vasos de Pressão destinam-se à instalação em sistemas de refrigeração, tais como em indústrias frigoríficas, abatedouros, indústria alimentícia, bebidas, indústria de energia, e demais aplicações.

A unidade é entregue para operação com um ponto específico de operação:

- Temperatura / pressão;
- Vazão mássica de gás / vazão volumétrica de líquido;
- Capacidade térmica.

Você encontrará os parâmetros e o modelo exato do seu equipamento nos documentos de projeto relacionados ao PRONTUÁRIO DO VASO DE PRESSÃO ou na reconstituição do documento.

OPERAÇÃO INADEQUADA

Fluidos de trabalho e suas combinações com água e outras substâncias nos componentes que transportam o fluido de trabalho têm efeitos químicos e físicos no interior dos materiais que os rodeiam.

A unidade só deverá ser pressurizada com o composto definido nos documentos de projeto relacionados ao pedido. A pressurização da unidade com outro fluido de trabalho poderá resultar em:

- Materiais estruturais e de soldagem usados não resistirão às tensões mecânicas, térmicas e químicas previsíveis, e a pressão que poderá ocorrer durante a operação e ao ser desligada será elevada demais;
- Os materiais, espessura da parede, resistência à tração, resistência à corrosão, processo e testes são adequados para o fluido de trabalho e não resistem à possíveis variações de pressões e tensões que podem ocorrer;
- O equipamento não resistirá a outros fluidos de trabalho e às outras misturas de fluidos de trabalho. Com exceção que tenha sido autorizado pela equipe técnica do fabricante ou PLH responsável pela análise de integridade física do vaso de pressão;
- O equipamento não permanecerá estanque durante a operação e quando for desligado;
- Uma possível fuga repentina de fluido de trabalho que poderia colocar pessoas e/ou propriedades e/ou o meio ambiente em risco.

A PMTA especificada na placa de identificação e na documentação de projeto relacionado ao pedido não deverá ser ultrapassada! Caso a pressão de trabalho for ultrapassada:

1. Os materiais estruturais e de soldagem usados não resistirão às tensões mecânicas, térmicas e químicas previsíveis, e a pressão que poderá ocorrer durante a operação e ao ser desligada;

2. O equipamento não permanecerá estanque durante a operação e quando for desligado.

3. Poderá haver uma fuga repentina de fluidos de trabalho após uma ruptura ou vazamento nos componentes que transportam o fluido de trabalho, que poderá resultar nos riscos abaixo:

- Perigo de fuga de materiais;
- Perigo de envenenamento;
- Risco de incêndio;

- Risco de explosão;
- Risco de queimaduras por produtos químicos;
- Risco de sufocamento;
- Riscos causados por reações de pânico;
- Poluição do meio ambiente.

PERIGOS TÉRMICOS RESIDUAIS

Perigo de queimaduras

Alerta contra superfícies quentes

Durante um serviço elétrico, a serpentina do trocador de calor da unidade, a tubulação (gás quente) e alguma partes do equipamento têm temperaturas acima de +45 °C.

O contato pode causar queimaduras.

Use proteção para as mãos

PERIGOS RESIDUAIS COM REFRIGERANTE

Estes perigos são relacionados essencialmente às propriedades físicas e químicas do fluido de trabalho e com as pressões e temperaturas que ocorrem nos componentes que transportam o fluido de trabalho no equipamento.

Para conhecimento dos perigos residuais dos refrigerantes é impreterível o conhecimento das FISPQ dos compostos (Ficha de Informação de Segurança de Produtos Químicos) fornecidas pelos fabricantes de refrigerante.

Segurança de Elementos Refrigerantes

Apesar de refrigerantes halogenados serem classificados como seguros, certas precauções devem ser tomadas quando manuseá-los.

O fluido refrigerante pode ser prejudicial se inalado. Quando liberado na atmosfera no estado líquido, o fluido evapora rapidamente, congelando tudo o que ele tocar.

Fluidos refrigerantes devem ser usados e recuperados com responsabilidade.

O não cumprimento deste aviso pode resultar em ferimento ou morte.

“PERIGO Amônia Anidra (NH₃) ”

Deve-se tomar um cuidado especial quando pessoas estão trabalhando com ou expostas à amônia.

A amônia é considerada um alto risco à saúde por ser corrosiva em contato com a pele, os olhos, e os pulmões.

A exposição a 300 ppm é imediatamente prejudicial à vida e a saúde.

A amônia é também inflamável em concentrações de aproximadamente 15% a 28% por volume no ar.

Quando misturada com óleos lubrificantes, sua taxa de concentração inflamável é aumentada.

Ela pode explodir se liberada em um local fechado com uma fonte de ignição presente, ou se um recipiente contendo amônia for exposto ao fogo.

Deve-se usar EPIs o tempo todo quando se trabalha com amônia.

Para sistemas que tem uma carga de operação maior que 4,5 kg, é obrigatório um programa de gerenciamento de segurança.

Mais informações sobre este assunto estão disponíveis na OSHA (Administração de Segurança e Saúde Ocupacional).

VASO DE PRESSÃO (SEPARADOR DE ÓLEO)

O objetivo deste guia de referência é apresentar recomendações de projeto para garantir a operação segura, critérios mínimos de segurança e manutenção para um sistema de refrigeração por amônia.

A serem aplicados pelas equipes de comissionamento, operação e manutenção do sistema, este guia abrange os aspectos de segurança a serem considerados, desde o período de comissionamento e “Start-Up” da instalação até as várias operações de campo, incluindo serviços de manutenção, revisões e inspeções periódicas dos vários componentes.

Este documento não tem função de norma nem substitui as obrigações necessárias requeridas por autoridades locais, estaduais ou federais quanto aos aspectos de segurança a serem cumpridos para obtenção de licenças de instalação e/ou funcionamento de um sistema de refrigeração por amônia.

Vasos de pressão Códigos e Normas Aplicáveis

Códigos e Normas aplicáveis

Os sistemas de refrigeração por amônia, possuem códigos e normas aplicáveis, nacionais e internacionais, como referência.

A seguir, os principais documentos disponíveis, relacionados à aplicação de amônia em sistemas refrigeração.

Normas Nacionais e Internacionais Normas Brasileiras:

NR-13 – 2025 – Caldeiras, Vasos de Pressão, Tubulações e Tanques Metálicos de Armazenamento – Normas Regulamentadoras da Legislação de Segurança e Saúde no Trabalho – Ministério do Trabalho – Lei nr. 6514 – 22/12/1977;

Manual de Orientação para a Elaboração de Estudos de Análise de Riscos – CETESB - Companhia de Tecnologia de Saneamento Ambiental - 13/08/2003;

NBR 13598 - Vasos de Pressão para Refrigeração – ABNT – Associação Brasileira de Normas Técnicas – 04/1996.

Normas Internacionais

ANSI/ASHRAE Standard 15-2007 - Safety Code for Mechanical Refrigeration - American Society of Heating, Refrigerating and Air Conditioning Engineers;

ANSI/IIAR 2-2008 - Equipment, Design & Installation of Ammonia Mechanical Refrigerating Systems – International Institute of Ammonia Refrigeration;

EN 378 Part 1-4 - 2008: Refrigerating systems and heat pumps - Safety and environmental requirements – European Committee for Standardisation.

ISO 5149:1993 – Mechanical Refrigerating Systems used for Cooling and Heating – Safety Requirements – International Organization for Standardization;

ANSI/ASME Refrigeration Piping and Heat B31.5 - 2006 – Transfer Components – American Society of Mechanical Engineers; AVISO 25

ANSI/IIAR Standard 3-2005: Ammonia Refrigeration Valves.

Código ASME para Dimensionamento de Vasos de Pressão;

ASME - Pressure Vessel Code - 2007 - Section VIII - Div. 1 - Rules for Construction of Pressure Vessels – American Society of Mechanical Engineers;

ASME - Pressure Vessel Code - 2007 - Section II - Materials - Part A – Ferrous Material Specifications – American Society of Mechanical Engineers;

ASME - Pressure Vessel Code - 2007 - Section II - Materials - Part C – Specifications for Welding Rods Electrodes and Filler Metals – American Society of Mechanical Engineers;

ASME - Pressure Vessel Code - 2007 - Section II - Materials - Part D – Properties – American Society of Mechanical Engineers;

ASME - Pressure Vessel Code - 2007 - Section V – Nondestructive Examination – American Society of Mechanical Engineers;

ASME – Pressure Vessel Code – 2007 – Section IX – Welding and Brazing Qualifications – American Society of Mechanical Engineers.

Refrigeração Em geral, define-se refrigeração como o processo de redução de temperatura de um corpo.

O surgimento de sistemas de refrigeração tornou-se essencial para o desenvolvimento da sociedade como a conhecemos, e fundamental para diversos segmentos da indústria, como a indústria alimentícia em geral, os frigoríficos, a indústria de pescado, as fábricas de gelo, os laticínios e a indústria de bebidas. Um dos principais fluidos utilizados na refrigeração é a amônia, cujo sistemas de refrigeração consistem de uma série de vasos e tubulações interconectados, que comprimem e bombeiam o refrigerante para um ou mais ambientes, com a finalidade de resfriá-los ou congelá-los a uma temperatura específica.

CARACTERÍSTICAS DA AMÔNIA ANIDRA R717

Características da amônia (NH₃ - R-717), na CNTP (Condição Normal de Temperatura e Pressão) se apresenta como um gás incolor, mais leve que o ar (apenas 9 gases na atmosfera são mais leves que o ar, sendo a amônia o quinto na lista) e possui um odor muito forte, que é facilmente perceptível, mesmo em concentrações muito pequenas (desde 5 ppm). amônia é um gás produzido naturalmente no processo biológico e é parte importante do ciclo do nitrogênio na terra.

O volume de amônia produzido pelo homem é equivalente a apenas 3% da quantidade total presente na natureza e o volume utilizado para sistemas de refrigeração é de cerca 0.5% do total produzido pelo homem.

Além disso, a amônia é altamente solúvel em água formando uma solução conhecida como Hidróxido de Amônio, ou no Brasil, amoníaco, (NH₄OH), normalmente utilizado em limpeza doméstica.

Comercialmente a amônia é produzida a partir da combinação de nitrogênio livre com hidrogênio a alta pressão e alta temperatura, na presença de um catalisador.

A amônia anidra requerida para os sistemas de refrigeração deve possuir um grau de pureza de 99.95%, com uma concentração de água de 33 ppm máx.

Propriedades Termo-Físicas da amônia

Impacto ao meio-ambiente

Amônia não destrói a camada de ozônio (ODP= 0) e, por ter um tempo de vida muito curto na atmosfera (máximo 15 dias), também não contribui para o efeito estufa (GWP=0).

Devido às suas excelentes propriedades termodinâmicas, a amônia requer menos energia primária para produzir uma certa capacidade de refrigeração do que quase todos os outros refrigerantes, de forma que o efeito indireto do aquecimento global, também é um dos mais baixos disponíveis.

Inflamabilidade

A amônia é considerada um fluido inflamável, porém em uma faixa muito restrita.

Os limites de inflamabilidade da amônia na pressão atmosférica são 15-16% (Limite Inferior de Inflamabilidade - LII) e 25-28% (Limite Superior de Inflamabilidade - LSI) em Inferior de Inflamabilidade - LII) e 25-28% (Limite Superior de Inflamabilidade - LSI) em volume no ar, com ponto de ignição de 651°C.

Esses limites associados ao baixo calor de combustão, reduzem em muito o potencial de inflamabilidade da amônia. Conforme o ANSI/ASHRAE 34-2007 [12] a amônia é classificada como um fluido do Grupo B2 (alta toxicidade e baixa inflamabilidade).

O potencial de inflamabilidade da mistura amônia-ar é influenciado por uma série de fatores tais como, pressão, temperatura, turbulência da mistura, potência da fonte de ignição e a presença de vapor de água, óleo ou de outros componentes. Uma característica importante das misturas inflamáveis é a velocidade da chama, que pode ser classificada como subsônica ou supersônica.

A propagação de uma chama em velocidade subsônica resultará em uma deflagração. Uma das características da deflagração é que a sobrepressão gerada pelo evento é relativamente baixa (a relação entre a pressão final e a pressão inicial é ligeiramente maior que 1.0, diferente da detonação, que pode gerar uma relação de pressão da ordem de 40.0). Apesar da sobre pressão gerada por uma deflagração ser baixa, estas podem causar danos às estruturas dos prédios e aos equipamentos ao redor (no caso de detonação certamente que os danos são devastadores).

Os eventos de deflagração são caracterizados por um nível de energia significativamente baixo quando da ignição da mistura inflamável.

Toxicidade

A amônia na fase gasosa ou líquida é um produto extremamente irritante.

O odor agressivo provocado pela amônia é uma característica significativa.

Devido à grande facilidade em se dissolver na água, a amônia acaba se impregnando na pele, na mucosa das narinas, na garganta e nos olhos. Isto provoca uma irritação muito forte e por reflexo condicionado os olhos se fecham e fica difícil a respiração.

Em concentrações mais altas ocorre um efeito corrosivo na mucosa das narinas provocando além da dificuldade da respiração, dor no peito, tosse e dispneia.

Em concentrações muito altas, pode provocar parada respiratória e, mesmo depois de horas da exposição, pode ocorrer edema pulmonar.

Mas se logo após os sintomas desaparecem (tosse, dor no peito) isto indica que não há maiores riscos.

A NR-15 , estabelece que o valor Limite de Tolerância de exposição de um trabalhador a um ambiente contaminado com amônia, durante uma jornada de trabalho semanal de 48 horas, é de apenas 20 ppm em volume no ar.

Os valores limites na maioria dos outros países está entre 25-35 ppm (40 horas) e um limite máximo de exposição 35-50 ppm por 15 minutos durante a jornada de trabalho.

O valor estabelecido como limite de risco de vida imediato, de qualquer pessoa exposta a um ambiente com amônia por mais de 30 minutos, é de 500 ppm.

Amônia líquida ou o gás a baixa temperatura podem causar fortes queimaduras na pele caso não haja nenhuma proteção.

Também a solução aqua-amônia pode provocar queimaduras devido ao pH alto da solução.

Portanto, após uma purga de amônia em um tanque com água, deve-se tomar muito cuidado com o esvaziamento do mesmo.

Normalmente seu odor característico e desagradável propicia amplo aviso antes que qualquer condição perigosa exista.

Pode ser detectada pelo olfato humano já a partir de 10 ppm, mas os operadores de plantas acabam se acostumando com concentrações de até 100 ppm sem efeitos desagradáveis

Reatividade

O cobre e todas as suas ligas, zinco e cádmio são prontamente atacadas pela amônia.

A amônia, causa grave corrosão sob tensão no cobre e em todas as ligas a base de cobre, que devem, portanto, ser evitadas para o contato com qualquer fluido contendo mesmo ínfimas quantidades de amônia.

A amônia anidra também pode causar corrosão sob tensão no aço-carbono, portanto, é requerido o uso de chapas de aço carbono adequadas para sistemas de refrigeração com amônia.

Em qualquer caso, a contaminação com ar, óleos, dióxido de carbono, etc, agrava sensivelmente o problema; em compensação, a adição de pequena quantidade de água inibe a corrosão sob tensão.

De acordo com o ANSI/ASME Standard B31.5 - 2006, é proibido o uso de tubos com costura em sistemas de refrigeração com amônia, incluindo toda tubulação e serpentinas ou tubos de trocadores de calor.

O Teflon, a Buna N, o Neoprene e as Borrachas Butílicas e Nitrílicas são polímeros aceitáveis para serviços com amônia, particularmente como vedação. Resinas de poliéster, borrachas polisulfonadas, viton, e resinas fenólicas não devem ser usadas.

PVC não plastificado é aceitável, mas com temperaturas inferiores a 0°C se torna quebradiço.

SEGURANÇA OPERACIONAL DO VASOS DE PRESSÃO

Segurança

Antes de iniciar qualquer procedimento é necessário que a equipe tenha total conhecimento das medidas de segurança cabíveis. Abaixo serão indicados, de forma orientativa, alguns pontos que exigem atenção, lembrando que qualquer procedimento de segurança deverá seguir as normas vigentes.

Precauções para manuseio de amônia EPIs - Equipamentos de Proteção Individual - não substituem condições seguras de trabalho, mas certas operações podem exigir alguma proteção mínima, enquanto que situações de emergência demandarão um alto grau de proteção pessoal.

Qualquer pessoa que eventualmente tenha que usar estes equipamentos deve estar totalmente treinada e conhecer suas limitações.

A seguir algumas recomendações sobre o uso de EPIs e precauções em operações de manuseio com amônia:

- Óculos ampla-visão e luvas, de Neoprene ou borracha, são os equipamentos mínimos a serem usados por qualquer pessoa trabalhando numa planta aberta, em condições normais;
- Para as operações de drenagem de óleo, purgas, retirada de amostras, deve-se proteger o corpo contra respingos e projeções, botas de borracha, luvas e, além disso, usar máscara panorâmica para proteção respiratória. Em alguns casos será necessário o uso de avental de PVC ou borracha clorobutílica;
- Use, sempre que for trabalhar com amônia, máscaras com o filtro apropriado e dentro do prazo de validade;
- O local de trabalho deverá ter ventilação adequada;
- Saiba onde se encontram os sistemas de respiração autônoma e como usá-los. No caso de uma emergência, deve-se usar equipamento de respiração autônoma, que proporciona a proteção total necessária numa manobra de resgate ou controle de situações críticas;
- Ao mais leve cheiro de amônia, coloque máscara e procure o vazamento, avisando a manutenção e interditando a área;
- Evitar que pessoas com doenças na visão e/ou pulmões transitem pela área e muito menos trabalhem neste local;
- Quando houver amônia líquida em tubulações ou vasos, esta deverá ser totalmente evaporada antes de qualquer serviço nestes itens, deixando a área livre e demarcada durante a operação;
- O supervisor de segurança deverá autorizar os serviços de manutenção mediante uma permissão para trabalho;
- Manter quaisquer outros compostos gasosos afastados da amônia, tais como Cloro, GLP, ácidos, etc.

Tratamento de primeiros socorros

É importante que em todos os atendimentos os socorristas estejam usando proteção respiratória adequada e removam a vítima do local para uma área livre e descontaminada mais próxima possível, e solicitem imediatamente a assistência médica e ambulância.

No caso do produto ter atingido os olhos a rapidez será vital. Os olhos devem ser lavados com solução lava-olhos ou água durante no mínimo 10 minutos.

Se não houver serviços médicos disponíveis a lavagem deve continuar por mais 20 minutos.

No caso do produto ter atingido a pele, as roupas que tiverem entrado em contato com o produto devem ser removidas e as partes do corpo atingidas devem ser lavadas abundantemente.

No caso de inalação de vapores, o acidentado deve ser colocado diretamente no solo para um possível tratamento de respiração artificial e/ ou massagens cardíacas.

Caso a respiração esteja difícil, aplicar oxigênio com aparelho de respiração controlada. Se a vítima parou de respirar, aplicar respiração artificial.

No caso de parada cardíaca, aplicar massagem cardíaca externa.

No caso de ingestão, forneça grandes quantidades de água para beber se a vítima ainda estiver consciente.

Não induza o vômito.

Um tratamento sintomático e de fortalecimento geral será necessário após a fase crítica da intoxicação.

As consequências de uma intoxicação com amônia não ultrapassam normalmente mais do que 72 horas, mas as lesões oculares poderão ser permanentes.

Se a exposição for severa, o paciente deverá ser mantido em observação médica por no mínimo 48 horas, uma vez que existe a possibilidade de edema pulmonar retardado.

Vasos de Pressão- controle de pressão

Todos os vasos de pressão e trocadores de calor deverão possuir suas respectivas plaquetas de identificação conforme os requisitos da NR-13 e do ASME Pressure Vessel Code, Section VIII, Division 1.

Os vasos de pressão, assim como a tubulação de interligação, deverão operar dentro dos limites de pressão e temperatura como especificados nas respectivas plaquetas de identificação.

Todo vaso de pressão deve possuir conexão específica para instalação de dispositivo de alívio de pressão, conforme definido pela NR-13 e dimensionado conforme Seção 9.7 e Anexo A da NBR 16069 ou Appendix H do ANSI/ASHRAE 15-2007.

As plaquetas de identificação deverão ser em AISI 304 e em caso de componentes com isolamento térmico, não devem ficar encobertas pelo isolamento.

Caso alguma plaqueta de identificação esteja encoberta pelo isolamento térmico (ou por pintura), este deve ser removido e reparado de modo que a plaqueta esteja sempre acessível à verificação.

Caso o vaso de pressão apresente sinais de corrosão além da corrosão superficial, o equipamento deverá ser inspecionado quanto à diminuição de espessura de chapa devido à corrosão, por um profissional qualificado, conforme requerido pela NR-13.

Qualquer alteração física em vasos de pressão deverá ser documentada no prontuário do equipamento, conforme requerido pela NR-13. Neste caso deverá ser ainda realizado novo teste de pressão do equipamento, assim como os demais ensaios requeridos aplicáveis.

Indicadores de nível de líquido em vidro

Todos os indicadores de nível de líquido utilizados para visualização do nível de fluido frigorífico em vasos de pressão deverão ser instalados em locais onde não sejam expostos a possíveis avarias devido a choques de veículos em trânsito (ex. empilhadeiras, caminhões).

Os indicadores de nível de líquido deverão possuir corpo blindado e vidros antirreflexivos, conforme a NBR 16069 (Item 9.11.2) e o EN 378-2 2000 (Item 6.2.7.3), com válvulas de bloqueio, com sistema interno de retenção de vazamento em caso de ruptura do vidro.

Indicadores de nível do tipo tubo de vidro não devem ser utilizados.

Os indicadores de nível deverão ser adequados à faixa de variação de nível de líquido para todas as condições de operação dos seus respectivos equipamentos (desde abaixo do nível mínimo e até acima do nível de alarme máximo).

Tubulação

A tubulação de amônia e seus acessórios deverão ser instalados conforme requerido no ANSI/IIAR 2-2008 - Section 10.

Todos os elementos de aperto (ex.: parafusos e porcas de flanges e tampas) sujeitos a pressão deverão ser periodicamente inspecionados quanto ao torque

de aperto adequado. Todos reparos em juntas deverão ser anotados no livro de registros de manutenção e reparos.

- Todo encaminhamento da tubulação em uma determinada instalação deverá ser inspecionado periodicamente para certificação de que não hajam trechos expostos a possíveis avarias devido a choques de veículos em trânsito (ex. empilhadeiras, caminhões).
- Todas as tubulações não isoladas devem ser inspecionadas periodicamente quanto a sinais de corrosão. Caso haja corrosão, o trecho de tubo deverá ser limpo até a superfície do metal de modo a se eliminar toda corrosão. Em seguida o tubo deve ser novamente pintado com pintura adequada, com revestimento anticorrosivo. Caso a corrosão seja intensa, o trecho de tubo deve ser substituído.
- Em toda tubulação com isolamento térmico que apresente sinais de falha na barreira de vapor, o isolamento térmico deverá ser removido para inspeção da tubulação. O tratamento deve ser o mesmo do parágrafo anterior.
- Toda tubulação de amônia deve ser marcada e sinalizada de maneira apropriada para indicar a utilidade (ou aplicação) de determinado trecho de tubulação, e setas indicadoras do sentido de fluxo. Como sugestão, recomenda-se o IIR Bulletin 114- 1991: Guidelines for Identification of Ammonia Refrigeration Piping and System Components. 6.3 Dispositivos de alívio de pressão
- Todo vaso de pressão (incluindo os vasos principais, vasos acumuladores para dreno de óleo, e demais vasos auxiliares do sistema de amônia) deverá ter instalado pelo menos uma válvula de alívio de pressão (simples ou dupla) ou outro dispositivo de alívio de pressão aplicável, conforme requerido na NR-13, no ANSI/ ASHRAE 15-2007 e na NBR 16069 (Seção 9.7).
- Não poderá haver nenhuma válvula de bloqueio instalada entre a válvula de alívio de pressão e a(s) parte(s) do sistema por ela protegida, exceto quando houver uma válvula de alívio de pressão dupla e uma válvula de 3-Vias em “manifold” de forma tal que uma das válvulas esteja sempre conectada à parte protegida, conforme requerido na NR-13, no ANSI/ ASHRAE 15-2007 e na NBR 16069 (Seção 9.7).

A válvula de 3-Vias deve ser mantida na condição de totalmente aberta como procedimento normal de operação.

- Toda válvula de alívio de pressão deve ser ajustada de forma tal que a pressão inicial de abertura da válvula não ultrapasse a pressão de projeto da(s) parte(s) por ela protegida, conforme requerido na NR-13, no ANSI/ ASHRAE 15-2007 e na NBR 16069(Seção 9.7).
- Toda válvula de alívio de pressão deve ser ajustada e lacrada pelo fabricante da válvula e marcada com uma plaqueta de identificação, conforme requerido na NR-13, no ANSI/ASHRAE 15-2007 e na NBR 16069 (Seção 9.7).

- Os dispositivos de alívio de pressão deverão ser conectados às respectivas linhas de descarga, conforme o ANSI/ASHRAE 15-2007 (Appendix H), a NBR 16069 (Anexo A) ou a Sec. 11.3 do ANSI/IIAR 2-2008, tendo em conta o dimensionamento adequado das linhas, a suportaçã das linhas e o local adequado para a descarga na atmosfera.
- Nenhuma válvula de alívio de pressão deverá ser instalada em ambientes refrigerados a menos que as devidas precauções sejam tomadas a fim de evitar a migração de umidade para dentro do corpo da válvula ou da linha de descarga.
- As válvulas de alívio de pressão deverão ser recalibradas ou substituídas periodicamente, conforme requerido na NR-13, quando da ocasião do Exame Interno do Vaso de Pressão (intervalo variável em função das características do vaso e das condições de operação).

Requisitos gerais de segurança

Todos os instrumentos deverão ser apropriados para operar com amônia, com fundo de escala, precisão e resolução adequada à faixa de operação do local ou equipamentos onde estiverem instalados.

Os mesmos deverão ser recalibrados ou substituídos periodicamente.

Instrumentos fora de escala, descalibrados ou inoperantes deverão ser substituídos.

Acumuladores de sucção, separadores de líquido, resfriadores intermediários deverão ser equipados com proteção contra nível alto de amônia líquida, que deve emitir um alarme de nível alto e, quando prático, deve atuar no desligamento parcial ou total dos respectivos compressores a fim de se evitar arraste de líquido para os compressores.

As válvulas de bloqueio principais do sistema; as válvulas de bloqueio das linhas de degelo por gás quente e as válvulas de bloqueio principais das bombas de amônia devem ser claramente identificadas, com sinais proeminentes de identificação e de fácil acesso.

Formação de gelo (externa) pode ser perigosa à tubulação de amônia ou a outros componentes do sistema. Esta deve ser removida e as condições que a causaram devem ser corrigidas.

Ruídos anormais e/ou vibrações de tubulação, ventiladores, bombas, pressostatos de proteção das bombas e efeito de “surge” na tubulação devem ser investigados e corrigidos/ eliminados.

Uma estação de lava olhos e chuveiro do tipo dilúvio devem ser localizadas na área externa mais próxima de cada porta de saída da sala de maquinas.

Uma estação adicional deve ser instalada dentro da sala de máquinas, com fácil acesso.

Nunca se deve manter um cilindro de carga de amônia conectado (mesmo que temporariamente) ao sistema, a não ser quando houver operação específica de carga de amônia e esta conduzida por pessoal qualificado, conforme requerido na Section 15.2 do ANSI/IIAR 2-2008.

Registros e Documentação

- A documentação relevante do sistema deve ser mantida pelo usuário em lugar seguro e disponíveis para verificação de detalhes relativos ao projeto, instalação, manutenção e operação do sistema.

- A documentação de projeto de um sistema de refrigeração deve incluir pelo menos os seguintes documentos atualizados:

- Fluxograma de engenharia da instalação;

- Descritivo operacional do sistema de refrigeração;

- Folhas de dados de operação nas condições de projeto dos principais componentes (compressores, condensadores, evaporadores, separadores de líquido, recipientes de líquido, resfriadores intermediários, economisers, bombas de amônia, etc.);

- Manuais de operação e manutenção dos principais componentes e elementos de controle; • Esquemas elétricos dos equipamentos e da instalação;

- Fluxograma do circuito de distribuição de ar do sistema de ventilação;

- Fluxograma e “layout” do sistema de detecção de vazamento de amônia;

- Prontuário dos vasos de pressão, conforme requerido pela NR-13; • Descritivo das lógicas do sistema de automação (quando aplicável);

- “Data-Book” do Sistema e principais componentes incluindo os relatórios dos testes de pressão e dos demais resultados dos testes realizados durante o comissionamento do sistema, até o “Start-Up”. Deverá ser utilizado um livro de registros de manutenção e reparos realizados no sistema de refrigeração com o registro de todas as ocorrências.

Deverá haver um registro de dados da quantidade de amônia adicionada ao sistema e da quantidade de óleo lubrificante adicionado e removido em cada compressor do sistema.

Recomenda-se que sempre estejam disponíveis as seguintes informações sobre o sistema de refrigeração:

- Nome e endereço para contato do instalador e/ou principais fornecedores;
- Inventário atual de amônia no sistema;
- Tipo e marca do óleo lubrificante e a carga atual;
- Registros dos testes de pressão aplicados ao sistema e aos equipamentos.

Recomenda-se ainda a utilização de quadros com instruções de emergência e com os telefones para contato com a equipe de brigada de emergência, corpo de bombeiros local, polícia e hospitais locais.

Deverá ser elaborado um plano de evacuação apropriado, com rotas de fuga claramente identificadas e pessoas responsáveis para a ativação do plano.

RECOMENDAÇÕES DE SISTEMAS DE REFRIGERAÇÃO POR AMÔNIA

Responsabilidades do operador do Sistema

Este capítulo trata da capacitação e das qualificações mínimas necessárias ao operador do sistema e tem como base o Bulletin R1 - 1983:

A Guide to Good Practices for the Operation of an Ammonia Refrigeration System

Deve-se enfatizar que é essencial um treinamento específico, com programa de reciclagem educacional contínua, para se manter uma equipe de operação capacitada e para garantia da operação segura do sistema.

Conhecimento Básico Inicialmente, para operação de um sistema de refrigeração por amônia, é necessário um conhecimento pleno dos fundamentos básicos de refrigeração, incluindo as características do ciclo de compressão à vapor, as relações pressão x temperatura do fluido refrigerante, as funções e características principais dos componentes do sistema de refrigeração e os aspectos envolvendo a sua segurança.

Não significa que o operador saiba como projetar um sistema, mas precisa ter conhecimento suficiente dos vários aspectos do mesmo, principalmente sobre o sistema no qual ele opera.

O Operador deve:

- Operar o sistema de maneira segura, conforme os requisitos de projeto e dentro das faixas limites de operação normal;
- Conhecer a função e operação de cada componente do sistema;
- Entender a operação combinada entre os vários componentes do sistema.

O operador deve estar familiarizado com os seguintes componentes e operação:

Válvulas de Controle Automático

A função básica das válvulas de controle é de regular automaticamente a pressão, temperatura, nível ou vazão de injeção de fluido refrigerante nos vários componentes do sistema.

É importante saber:

- O funcionamento da válvula (princípio de operação e condições);
- Qual a função de regulagem da válvula;

Quais os ajustes da válvula e como ajustá-la para determinada condição de operação e controle;

- O que acontece com o sistema quando a válvula abre ou fecha;
- O que acontece com o sistema quando a válvula é isolada do restante do sistema ou quando há um “bypass” manual;
- O que acontece com a válvula e o sistema quando há uma falha de energia.

O que acontece quando a válvula é re-energizada.

Válvulas de Bloqueio

Estas válvulas são instaladas no sistema com a função de isolar certos componentes do restante do sistema ou de bloquear/parar o fluxo de fluido refrigerante.

Elas podem ser operadas manualmente, ou através de comando elétrico, pneumático e até através de piloto pelo fluido refrigerante pressurizado.

É importante saber:

- Onde cada válvula de bloqueio está localizada no sistema;
- O que acontece com o sistema quando se abre ou fecha a válvula;
- Qual a posição normal de operação da válvula (normalmente aberta ou normalmente fechada);
- Como determinar se a válvula está aberta ou fechada (quando não há uma indicação externa evidente).

Válvulas de Alívio de Pressão (Válvula de Segurança)

As válvulas de alívio de pressão tem a função essencial de evitar que haja rupturas devido à pressão excessiva em vasos de pressão, compressores, trocadores de calor, descargas de bombas de amônia e em alguns trechos da tubulação.

Todas as válvulas de segurança precisam ser inspecionadas periodicamente, conforme os requisitos da legislação.

O operador deve saber:

- A localização das válvulas de alívio de pressão no sistema;
- O ponto de ajuste correto de cada válvula de alívio de pressão.

Cada válvula deve ser distintamente identificada e “taguada”;

- Qual componente ou parte do sistema cada válvula foi designada para proteger;

- Qual ação (condição de desvio de operação) deve ocorrer para que a válvula eventualmente venha a atuar.

Controles Elétricos/Eletrônicos

O sistema de refrigeração possui vários componentes de controle elétrico ou eletrônico tais como disjuntores, fusíveis, relés, temporizadores, malhas de controle e várias funções de proteção controladas por sistema computadorizados.

Muitos deles localizados em um painel elétrico, painel microprocessado ou ainda na tela de um sistema de supervisão e gerenciamento do sistema de refrigeração. É responsabilidade do operador conhecer plenamente:

- Qual o propósito de cada controle;
- Qual componente ou parte do sistema cada controle é designado para proteger;
- O que fazer em caso de falha de energia;
- O que acontece com o sistema em um período longo de desligamento;
- Qual a sequência de operação para desligamento completo do sistema;
- Qual a sequência de operação para a entrada em funcionamento do sistema;
- Como aliviar o sistema devido a uma elevação de pressão provocada por uma parada do sistema, durante a uma falha de energia.

Mudanças de Temperatura/Pressão no Sistema

São muitos os fatores que podem afetar as temperaturas e pressões normais de operação do sistema de refrigeração incluindo mau funcionamento mecânico ou elétrico, temperatura ambiente, carga de produto, etc.

É importante saber:

- Quais as condições de projeto e as condições normais de operação do sistema, incluindo temperaturas e pressão de cada regime de operação;
- Quais as causas e efeitos em caso de mudança de temperatura ou pressão:

No lado de baixa pressão do sistema;

Na pressão intermediária do sistema (para sistemas de duplo estágio);

No lado de alta pressão do sistema.

- Em caso de desvio operacional, quais ações serão tomadas de modo a restaurar as condições normais de temperatura e pressão nos vários pontos do sistema.

Recolhimento de Fluido Refrigerante

Um sistema de refrigeração bem projetado inclui a facilidade de se transferir o fluido refrigerante de uma parte para outra do sistema com o propósito de manutenção.

Cada operador deve ser bem treinado para realizar operações de recolhimento e transferência em todas as partes do sistema. Além disso, deve saber:

- Qual ação tomar quando houver uma elevação de pressão no sistema;
- Qual ação tomar em caso de um vazamento não previsto;
- Como realizar as operações de recolhimento no sistema ou manter vácuo nos diferentes componentes do sistema, para realização de reparos.

Manutenção Preventiva

Um dos fatores mais importantes para a operação segura do sistema de refrigeração é o conhecimento do operador com relação à manutenção preventiva dos vários componentes do sistema.

Cada componente requer uma rotina de inspeção, limpeza ou ajuste interno e possivelmente a substituição.

As seguintes operações/ revisões devem ser realizadas periodicamente:

- Controles de Segurança devem ser inspecionados e testados através de operação manual para garantir que os mesmos estão funcionando corretamente. Quando em falha, deverão ser substituídos imediatamente;
- Válvulas de Bloqueio devem ser verificadas quanto à vedação completa através de manobras periódicas de inspeção de cada válvula. O castelo deve estar livre de pintura ou ferrugem e o corpo da válvula livre de vazamento;
- Válvulas de Controle Automático devem ser verificadas através da sua operação manual. Componentes defeituosos tais como bobinas de solenóides, pilotos e as partes internas (mecânicas) devem ser imediatamente substituídas. Filtros de linha antes das válvulas devem ser limpos, especialmente se for verificado alguma perda de capacidade;
- Drenos de Óleo devem ser verificados e o excesso de óleo deve ser removido com a frequência necessária. Se houver um aumento da frequência de drenagem de óleo é um sintoma que há arraste excessivo de óleo dos compressores para o sistema;
- Válvulas de Expansão devem ser verificadas quanto ao ajuste correto. Em caso de válvulas eletrônicas os sensores de pressão e temperaturas deverão ser calibrados periodicamente;

- Manômetros e Termômetros de Campo, Sensores Temperatura e Transdutores de Pressão devem possuir um programa de calibração periódico;
- Visores de Nível devem ser mantidos limpos e desobstruídos. Devem ser protegidos de maneira adequada. Tubos de vidro devem ser evitados e substituídos por visores blindados com proteção externa;
- Controladores de Nível e Sensores de Nível e Alarmes de Nível devem ser inspecionados e testados através de operação manual para garantir que os mesmos estão funcionando corretamente. Quando em falha, deverão ser substituídos imediatamente;
- Bombas de Refrigerante devem ser verificadas quanto ao desempenho através de medições constantes das pressões de sucção e descarga e da corrente dos motores.
- Equipamentos de Proteção Individual e Coletiva tais como máscaras, luvas, aparelhos autônomos de respiração, lava-olhos, chuveiros e sinalização de emergência devem ser verificados regularmente;
- Procedimentos de Emergência devem ser frequentemente executados em exercícios simulados e revisados pelo menos a cada 2 anos.

Outros itens a serem constantemente inspecionados:

- Tubulação de amônia e suportes da tubulação devem ser inspecionados quanto à vibração.

O isolamento térmico também deve ser verificado em toda sua extensão quanto a danos ou rompimento da barreira de vapor, condensação ou congelamento no revestimento externo;

- Vazamentos: Uma boa instalação de amônia não deve ter vazamentos.

Caso sejam verificados traços de óleo em conexões flangeadas ou próximo a válvulas se perceber o odor de amônia, os mesmos devem ser verificados. É importante uma verificação periódica nos vários pontos sujeitos a vazamentos na instalação;

- Sistemas Hidrônicos devem ser verificados quanto à possibilidade de vazamentos através de análise periódica da qualidade de água se há traços de contaminação com amônia.

Vasos de Pressão

“START-UP” de novas instalações

Aqui será apresentado um resumo dos procedimentos aplicados durante o processo de comissionamento e “Start-Up” para um sistema de refrigeração por amônia e tem como base o Bulletin 110 - 1993:

Guidelines for Start Up, Inspection and Maintenance of Ammonia Mechanical Refrigerating Systems [10].

Precauções Iniciais

Considera-se inicialmente que a instalação foi projetada corretamente para o propósito do seu desempenho; que toda tubulação de interligação, componentes elétricos e isolamento térmico foram corretamente instalados; que todos os dispositivos de proteção foram testados e ajustados e que estão funcionais; que todo sistema foi submetido ao teste de pressão; e que todos os elementos necessários para o “Start-Up” do sistema foram previamente providenciados.

O supervisor da instalação deve possuir todos os desenhos relevantes do sistema, incluindo o fluxograma de engenharia, os diagramas elétricos e os dados de projeto de operação do sistema, assim como as condições limites de operação.

O engenheiro designado pelo proprietário como Autoridade de Comissionamento deverá possuir toda documentação de qualificação para as atividades de “Start-Up” e deverá conduzir o processo em conjunto com o supervisor da instalação. Antes da primeira carga de amônia no sistema, deverá ser verificado que todos os sistemas de emergência estão funcionais, incluindo rotas de fuga e estações de lavaolhos e chuveiros e que os EPIs (equipamentos de proteção individual) necessários estão disponíveis e de fácil acesso aos profissionais envolvidos.

Todo pessoal das outras áreas da unidade (externos à instalação de refrigeração) deve ser notificado que será realizada a carga de amônia.

O acesso à área deverá ser restrito apenas ao pessoal autorizado e os que não estão envolvidos na operação devem ser mantidos fora da área de risco.

Deverá ser realizada uma inspeção visual sobre toda tubulação, interligação elétrica e condição de abertura das válvulas de bloqueio (conforme sua condição normal de operação) para certificação de que o sistema está pronto para receber a carga de amônia.

Comissionamento da Instalação Elétrica

Qualificação da instalação a ser realizado antes da primeira carga de amônia no sistema. Durante o comissionamento da instalação elétrica, os painéis de controle dos equipamentos deverão ser inspecionados internamente e externamente, para se garantir que todo equipamento e componentes especificados foram corretamente instalados e que todos os disjuntores e

fusíveis dos painéis foram dimensionados corretamente como indicados na especificação.

Antes de energizar qualquer parte do circuito elétrico da instalação, deverá ser conduzido um teste de isolamento de todos os cabos para garantir que não haverá falhas de isolamento.

Recomenda-se a emissão de um certificado do teste.

Para testes dos painéis de controle, todos os fusíveis/ disjuntores dos motores dos equipamentos principais e auxiliares (incluindo motores dos compressores, bombas, ventiladores, etc.) deverão ser retirados de modo a evitar o funcionamento inesperado de algum dos equipamentos.

Com os fusíveis dos motores dos equipamentos removidos, o acoplamento (ou as correias) entre os compressores e seus motores devem ser desconectados e os equipamentos devem ser manualmente rotacionados para se constatar que os mesmos giram livremente.

Em seguida, à medida que os fusíveis são novamente instalados, os motores deverão ser testados um a um, para verificação do sentido correto da rotação.

Deverá ser confirmado o valor de ajuste da proteção térmica de cada motor, tendo como base a corrente nominal do motor.

Para os motores dos compressores, em certos casos, será necessário desativar alguns intertravamentos elétricos para testar o motor.

Neste caso, os intertravamentos desativados deverão ser sinalizados, para serem reativados corretamente após o teste.

Após a verificação do sentido da rotação dos motores, os cabos de alimentação dos motores deverão ser isolados e os motores serão reacoplados.

Os motores serão alinhados com os equipamentos e as proteções dos acoplamentos serão reinstaladas.

Quando finalizados estes testes do circuito elétrico, todas as proteções elétricas de desligamento (dos motores) deverão ser inspecionadas para se garantir que os valores de ajuste estão de acordo com os valores requeridos nas especificações.

Finalmente, deverão ser testados os intertravamentos elétricos dos diversos elementos de controle e proteções (tais como, bóias de nível com contato elétrico, pressostatos, termostatos, sensores de fluxo, etc.) para certificação que os contatos elétricos estão atuantes sobre os motores dos respectivos equipamentos.

Todos os resultados dos testes devem ser registrados e anexados ao relatório final do comissionamento da instalação elétrica.

Teste de Estanqueidade de Sistema

Após a finalização da instalação e antes da aplicação do isolamento térmico, o sistema de refrigeração deve ser testado para certificação da estanqueidade ou de eventuais vazamentos.

Todas as partes do sistema que não foram testadas previamente (em fábrica ou no campo) deverão ser pressurizadas conforme as pressões de projeto requeridas (considerando os valores específicos para o lado de alta e o lado de baixa pressão).

Todos os vazamentos detectados deverão ser reparados e o material ou as partes defeituosas deverão ser substituídas.

Não se deve utilizar Oxigênio ou qualquer gás combustível ou mistura combustível para a pressurização.

Dióxido de carbono (CO₂) ou fluidos halogenados (HFCs, HCFCs, CFCs) não podem ser utilizados como gases para pressurização em sistemas com amônia.

Recomenda-se a utilização de Nitrogênio seco ou ar seco como gás de pressurização para o teste de estanqueidade.

A seguir os procedimentos mínimos recomendados para o teste:

Preparação

Os seguintes componentes deverão ser fechados, bloqueados e/ou isolados, contra a pressurização:

- Unidades compressoras;
- Válvulas de segurança (utilizar disco de blindagem e juntas);
- Indicadores de nível (as válvulas de purga, após as válvulas de bloqueio, devem permanecer abertas);
- Controladores de nível;
- Bombas de amônia;
- Extrator (Purgador) de ar;
- Indicadores de pressão (manômetros);
- Todo e qualquer eventual instrumento de baixa pressão e acessórios;

- Todas as válvulas solenoides deverão permanecer abertas, por meio de energia elétrica (se normalmente fechadas), ou através dos próprios dispositivos de operação manual;
- Válvulas motorizadas e/ou pneumáticas também deverão permanecer na condição aberta;
- Válvulas de retenção localizadas na descarga das unidades compressoras deverão ser desmontadas para retirar o miolo interno, a fim de permitir a passagem de pressão até as válvulas de fechamento;
- Todas as flanges pertencentes à tubulação (se houver) deverão ser revestidos na junção com uma fita adesiva e, um pequeno furo deverá ser efetuado na parte superior. Obs.: Deverá ser verificado, previamente, através de uma cópia do fluxograma da planta, que toda a tubulação a ser testada (soldas, conexões, ligações, flanges, juntas, etc.) será atingida pela pressão a ser introduzida; e o fluxograma, devidamente marcado por indicação em cor, deverá ser anexado ao Certificado de Teste de Pressão. Em caso de sistemas com pressões de teste diferentes entre o lado de baixa e o lado de alta pressão, os lados deverão ser isolados e os testes deverão ser realizados em etapas distintas, considerando as respectivas pressões requeridas.

Precauções quanto a proteção de pessoas

Toda a área da instalação a ser pressurizada, deverá ser interditada, e somente será permitida a presença de pessoas a uma distância mínima de 10 metros do extremo da instalação, protegidas por meio de anteparos de concreto.

Avisos adequados deverão ser colocados em locais estratégicos para se evitar a entrada inadvertida de pessoas.

A equipe de segurança da empresa e/ou do corpo de bombeiros da localidade (previamente acionado pela empresa) deverão garantir isolamento da área, permitindo acesso apenas à equipe de teste.

Deve-se atentar para o fato da existência constante do risco de possíveis rupturas de tubos e/ou componentes, colocando em risco a vida das pessoas nas proximidades.

Portanto, todas as pessoas presentes ao teste deverão estar adequadamente protegidas.

Equipamentos a serem utilizados

- Compressor de ar com pressão de descarga até 6 bar e compressor de ar com pressão de descarga até a pressão de teste, a serem instalados em locais apropriados e distantes da instalação, a fim de garantir a proteção dos operadores;

Obs.: Os compressores de ar deverão possuir válvula de segurança e manômetro.

- Cilindros de Nitrogênio;
- Termômetro de mercúrio calibrado, com divisão de escala no mínimo de 0.1°C e manômetros de alta pressão, calibrados e com divisão de escala no mínimo de 0.10 bar, a serem instalados na Sala de Máquinas, para controlar as diversas variações das condições ambientais, as quais influenciam diretamente nos resultados dos testes;

Procedimento

1º Estágio

- a) Pressurização da instalação com ar comprimido seco e/ou Nitrogênio, até a pressão de 200 kPa g (2.0 bar g);
- b) Verificação cuidadosa de todas as soldas e conexões quanto a vazamentos, por meio de solução de água e sabão;
- c) Marcação dos eventuais vazamentos observados para posterior correção;
- d) Elevação da pressão para 4 bar g e realizar nova verificação de vazamentos;
- e) Despressurização da instalação e realização dos eventuais reparos.

Não realizar nenhum reparo com o sistema pressurizado.

2º Estágio

- f) Injeção de ar comprimido seco e/ou Nitrogênio até obter a pressão de teste em condição estável;
- g) Manter a pressão de teste por 2 horas, com variação inferior a 1% e em seguida reduzi-la para 1050 kPa g (10.5 bar g); h) A pressão de 1050 kPa g (com variação inferior a 1%) deverá ser mantida por um período de 12 horas;
- i) Todas as soldas e conexões serão novamente verificadas por meio da solução de água e sabão, antes da despressurização total da instalação;
- j) Caso seja detectado algum vazamento, após a despressurização do sistema, os eventuais reparos deverão ser realizados e o teste deverá ser executado novamente até que se garanta a total estanqueidade;
- k) Emissão de Certificado de Teste de Estanqueidade.

Procedimento de vácuo e desidratação

Após a certificação do teste de estanqueidade, antes da aplicação do isolamento térmico e antes de realizar a carga de amônia, o sistema deverá ser cuidadosamente evacuado para remoção de todos os gases não condensáveis e da umidade contida no interior do sistema. A evacuação pode durar de 25 a 40 horas para atingir a pressão requerida, dependendo do volume interno da instalação, do conteúdo de umidade presente no interior do sistema e da capacidade e estado da bomba de vácuo utilizada.

O nível de vácuo a ser atingido para sistemas que irão operar com amônia é cerca de 0.66 kPa abs (5.0 mmHg).

Nessa pressão o ponto de ebulição da água é de +/- 0°C.

Preparação

Todos os componentes que foram isolados para a execução do teste de estanqueidade, exceto os compressores e bombas de amônia (que em vácuo permitirão a penetração de ar através dos selos mecânicos), deverão ser abertos e/ ou desbloqueados:

- Bombas de amônia (quando herméticas);
- Válvulas de segurança (retirar os discos de blindagem);
- Indicadores de nível (fechar a válvula de purga e abrir as válvulas de bloqueio);
- Controladores de nível (fechar a válvula de purga e abrir as válvulas de bloqueio);
- Extrator (Purgador) de ar;
- Indicadores de pressão (manômetros) e controladores de pressão (pressostatos);
- Todo e qualquer instrumento de baixa pressão e acessórios eventualmente isolados;
- Todas as válvulas solenoides (24 Vdc ou 120 Vac), deverão permanecer abertas, por meio de energia elétrica, ou através dos próprios dispositivos de operação manual;
- As válvulas motorizadas e/ou pneumáticas também deverão permanecer na condição aberta;
- As válvulas de retenção localizadas na descarga das unidades compressoras deverão ser remontadas.

Equipamentos a serem utilizados

- Bomba de vácuo de tamanho adequado (capacidade de 10 a 25 Nm³/h);

- Manovacuômetro com escala de vácuo em kPa abs ou em mmHg (Torr) e “manifold”;
- Tubo de aço carbono ou mangueira flexível com trama em aço inox apropriada, com conexões fêmeas em ambas as extremidades;
- Cilindros de Nitrogênio.

Procedimento

A conexão da bomba durante o processo de vácuo será feita através da válvula de carga, localizada na descarga da tubulação do recipiente de líquido, por meio de tubo ou da mangueira flexível.

Vácuo Primário

Inicia-se a evacuação e, durante o processo, a pressão poderá ser verificada no manovacuômetro, onde percebe-se que a pressão no interior da instalação (atmosférica, aprox. 100 kPa abs ou 760 mmHg) decresce rapidamente até cerca de 3 kPa abs (~20 mmHg), ou ligeiramente abaixo.

Até o presente, apenas o ar e os gases incondensáveis foram removidos.

Em seguida a pressão passa a diminuir mais lentamente, pois só então a água começa a evaporar. Recomenda-se verificar os pontos baixos onde pode haver enclausuramento de água e aquecer estes pontos para acelerar o processo de evaporação.

Quando a pressão atingir aproximadamente 0.7 kPa abs (5.5 mmHg), após cerca de 15 horas do início do processo, a bomba será desligada por um período de 1 hora e a pressão será verificada no manovacuômetro.

Um aumento da pressão indica a evaporação da umidade que ainda se encontra no sistema.

Neste caso, continuar o processo por mais 10 horas, e em seguida desligar a bomba novamente, para a verificação da estabilidade da pressão.

O processo deve continuar até que a pressão atinja o valor de 0.66 kPa abs(5.0 mmHg) e se mantenha estável.

Em seguida a bomba será desligada e isolada do circuito e essas condições serão mantidas por mais 6 horas.

8.4.5 Quebra de vácuo O vácuo atingido será “quebrado” por meio da injeção de Nitrogênio no sistema, até que a pressão retorne à pressão atmosférica inicial.

Vácuo Secundário

A evacuação é efetuada novamente até que a pressão atinja o valor de 0.66 kPa abs (5.0 mmHg).

Carga Primária de amônia

Após o processo do vácuo secundário, a instalação estará apta para receber a primeira carga de amônia.

Inicialmente, a carga será realizada até o sistema atingir 700 kPa g (7.0 bar g).

Recomenda-se ainda que durante este período o sistema seja inspecionado com detectores de amônia.

Máscaras apropriadas deverão estar disponíveis em caso de emergência.

Ao final, todos os componentes, válvulas e elementos de controle deverão ser retornados à posição normal de operação com o sistema parado.

Carga de amônia

Em caso do uso de cilindros para a carga de amônia, recomenda-se conectar apenas um cilindro por vez.

Em caso de alimentação por mais de um cilindro, deve-se tomar o cuidado para que não haja fluxo de um cilindro para o outro através do uso de válvulas de retenção em cada conexão de alimentação de cada cilindro, de modo a impedir o fluxo para dentro dos cilindros.

A válvula de carga de amônia para o sistema deve ser compatível com o tamanho do sistema e deve possuir uma válvula de retenção para impedir retorno de fluxo do sistema para o elemento de carga (cilindro ou caminhão tanque).

O ponto de carga e o cilindro deverão estar posicionados em área externa, em um local protegido, onde não haja risco para o restante da equipe de operação.

A área deve ser isolada e um aviso deve ser colocado informando que o sistema está sendo carregado com amônia.

Quando utilizado caminhão tanque, recomenda-se bombear amônia para o recipiente de líquido utilizando bombas de amônia próprias do caminhão (quando houver).

No caso de caminhão tanque, o fornecedor de amônia deverá apresentar a seguinte documentação para liberação do abastecimento:

- Identificação da carga de amônia, com informações do fabricante da amônia, certificado de procedência e certificado de pureza (mínimo de 99.95%);
- Certificado de procedimento de vácuo no tanque do caminhão antes da carga de amônia; • Procedimento escrito das operações de abastecimento de amônia;

- Certificado de integração do profissional para atividade de risco na área e certificado de treinamento do profissional para o procedimento de operações de abastecimento de amônia.

O fornecedor deverá ainda prover mangueira apropriada e conexão de engate rápido para o ponto de carga de amônia da instalação.

Em caso de diferença de diâmetros entre a mangueira e a conexão de carga do sistema, não poderão ser utilizadas reduções em série (montadas na hora) para a conexão.

O fornecedor deverá prover um dispositivo de redução apropriado e que já seja montado na mangueira.

Antes de iniciar a operação, inspecionar a mangueira do fornecedor verificando se a mesma é adequada para a operação e se há um ponto de dreno para esvaziamento final da mangueira após a carga.

Prover água em abundância no local (mangueira com água corrente) e utilizar EPI adequado para o serviço (pelo menos botas, luvas e máscara específica).

Após instalar a mangueira que interliga o caminhão tanque com o ponto de conexão de carga de amônia da instalação deverá ser realizado o seguinte procedimento de carga:

- Registrar o volume inicial de amônia no recipiente de líquido;
- Abrir a válvula de conexão de carga de amônia da instalação (100%);
- Seguir a operação conforme o procedimento escrito do fornecedor;
- Durante o procedimento, o operador de carga de amônia deve permanecer ao lado do conjunto de válvulas do caminhão para o fechamento imediato das válvulas de carga em caso de emergência;
- Quando a carga estiver completada, fechar a válvula de conexão de carga de amônia da instalação;
- Fechar a válvula de conexão de amônia do caminhão-tanque;
- Drenar o resíduo de amônia do trecho da mangueira para um tambor com água;
- Retirar a mangueira das conexões de carga de amônia da instalação e do caminhão tanque;
- Registrar a massa da carga de amônia injetada na instalação. Para o cálculo da massa total injetada, além do registro da variação de volume no recipiente de líquido (e posterior cálculo de massa através da densidade da amônia na

temperatura ambiente), recomenda-se pesar cada cilindro antes e depois da carga ou pesar o caminhão tanque antes e depois da carga (quando possível).

Durante o procedimento de carga, um dos compressores (de preferência de duplo estágio e de menor capacidade), deverá estar preparado, com a devida carga de óleo e ligação elétrica, para entrar em funcionamento.

Deve-se levar em conta que durante este período, o compressor estará operando fora das condições normais de operação (pressão e temperatura) para as quais o sistema foi projetado.

Testes dos Dispositivos de Proteção do Sistema

Os testes dos dispositivos de proteção dos compressores deverão ser executados pelo profissional responsável pelo “Start-Up” dos compressores (designado pelo fabricante dos compressores).

Os demais dispositivos deverão ser executados pelo profissional responsável pelo “Start-Up” do sistema (designado pelo instalador) e/ou responsáveis pelos outros equipamentos fornecidos.

Os testes deverão ser conduzidos e supervisionados pelo engenheiro designado pelo cliente como autoridade de Comissionamento.

Todos os dispositivos deverão ser verificados previamente para certificar que os valores de ajuste de campo estão de acordo com o valor de ajuste estabelecido no projeto para cada dispositivo.

Alta pressão de descarga

Este deverá ser o primeiro dispositivo a ser testado.

O valor de ajuste do dispositivo de proteção de alta pressão de descarga do alívio de pressão instalado no lado de mesma pressão de operação do dispositivo de proteção do compressor.

Para o teste, a pressão de descarga de cada compressor deve ser aumentada gradativamente (através do fechamento de válvula na linha de descarga, após o ponto de tomada de pressão onde está instalado o dispositivo), até que o dispositivo de proteção atue, provocando o desligamento imediato do compressor quando a pressão atingir o valor de ajuste.

Caso a pressão de descarga ultrapasse o valor de ajuste do dispositivo de proteção, o compressor deverá ser desligado imediatamente (através de botão de emergência, ou de parada instantânea).

Neste caso, o dispositivo deve ser substituído ou reparado (deverão ser verificados os elementos mecânicos e elétricos do dispositivo) e após a correção, o teste deverá ser refeito.

Em compressores com painéis de controle microprocessados, o valor de ajuste da pressão de descarga para desligamento poderá ser diminuído durante o teste para facilitar o procedimento e evitar pressão muito elevada no sistema.

Após a conclusão do teste, o valor de ajuste deverá ser corrigido para a condição estabelecida no projeto.

Baixa pressão de sucção

Para o teste, a pressão de sucção de cada compressor deve ser diminuída gradativamente (através do fechamento de válvula na sucção), até que o dispositivo de proteção atue, provocando o desligamento imediato do compressor quando a pressão atingir o valor de ajuste.

Caso a pressão de sucção ultrapasse o valor de ajuste do dispositivo de proteção, ou o compressor deverá ser desligado ou a pressão de sucção elevada (através da abertura da válvula).

Neste caso, o dispositivo deve ser substituído reparado (deverão ser verificados os elementos mecânicos e elétricos do dispositivo) e após a correção, o teste deverá ser refeito.

Baixa pressão diferencial de óleo

O dispositivo de proteção da pressão diferencial de óleo do compressor, normalmente está associado a um temporizador para evitar a parada do compressor durante a partida quando a pressão diferencial de óleo é baixa. Isto deve ser levado em conta durante o procedimento de teste.

O teste do temporizador pode ser realizado em bancada específica montada no local ou através do isolamento das tomadas de pressão do dispositivo de pressão diferencial do óleo (caso hajam válvulas de bloqueio dos pontos de tomada de pressão).

O dispositivo de proteção de pressão diferencial de óleo poderá ser testado alterando-se o valor de ajuste para um valor superior ao de projeto para facilitar o procedimento. Após a conclusão do teste, o valor de ajuste deverá ser corrigido para a condição estabelecida no projeto.

Alta temperatura de descarga/ alta temperatura de óleo

Em compressores com painéis de controle microprocessados, recomenda-se alterar o valor de ajuste da temperatura de desligamento para um valor inferior durante o teste. Após a conclusão do teste, o valor de ajuste deverá ser corrigido para a condição estabelecida no projeto.

Outros dispositivos de proteção

Todos os demais dispositivos de proteção de alarme e desligamento dos compressores deverão ser testados, incluindo dispositivos para baixa temperatura e dispositivos de proteção externos, tais como controladores de nível de líquido (alarme e desligamento por nível alto ou nível baixo).

Também deverão ser testados os dispositivos de proteção dos demais equipamentos, tais como bombas de amônia e máquinas fabricação de gelo.

Os testes deverão ser realizados conforme as recomendações do fabricante.

Sistemas de proteção de emergência

Também deverão ser testados os seguintes sistemas auxiliares:

- Sistema de Ventilação Normal da Sala de Máquinas;
- Sistema de Ventilação de Emergência;
- Botões de Emergência (parada instantânea de equipamentos e da instalação);
- Válvula Solenóide Principal da Linha de Líquido;
- Estações de Lava-Olhos e Chuveiros tipo Dilúvio de Emergência;
- Detectores de amônia.

Os testes deverão ser realizados conforme as recomendações do fabricante.

Operação assistida

Após a conclusão dos testes dos dispositivos de proteção, as rotinas do “Start Up” poderão seguir adiante com os ajustes das válvulas de controle e demais elementos de controle para a correta operação dos equipamentos e do sistema.

Durante o procedimento de “Start-Up” deverá haver um monitoramento das pressões e temperaturas de operação do sistema e constantes inspeções sobre vazamentos de amônia.

Em caso de qualquer anormalidade, o sistema deve ser parado imediatamente e as causas devem ser identificadas e corrigidas antes de retornar ao funcionamento.

DIMENSIONAL

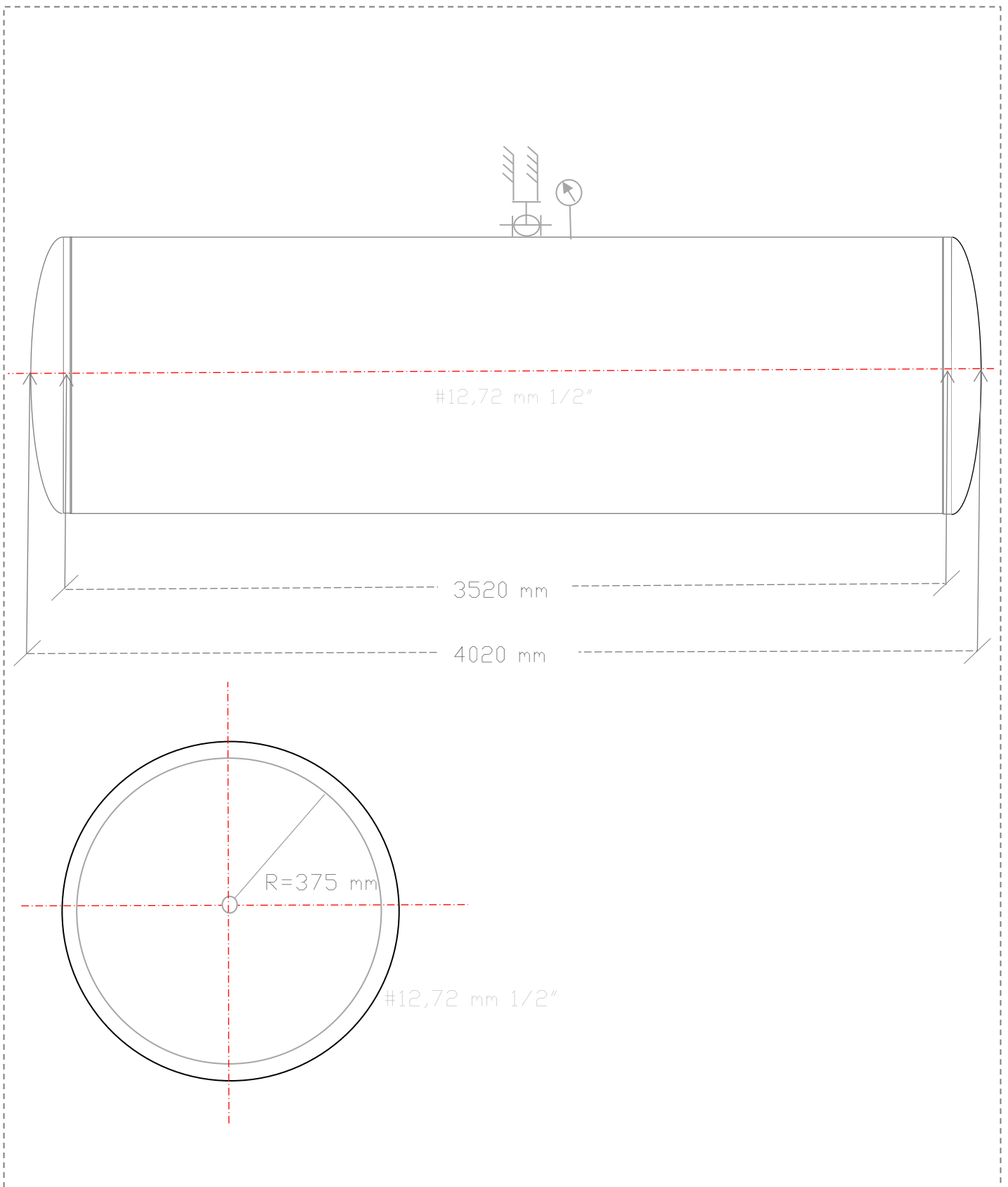

RESPONSABILIDADE TÉCNICA

Responsabilidade Técnica

Alfa Service

57.413.969/0001-01

ART - Supervisão/Coordenação

13202501355172

Renato Rodrigues Borges

Engenheiro Mecânico/Engenheiro de Segurança do Trabalho

Crea 1008294713D-GO

5071587938-SP

RNP: 1008294713

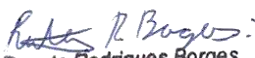
Renato Rodrigues Borges
Eng. Mecânico
CREA: 1008294713D-GO

Bataguassu, 01 de Dezembro 2025



Anotação de Responsabilidade Técnica -
ART Lei nº 6.496, de 7 de dezembro de 1977

CREA-MS

ART DE OBRA/SERVIÇO
1320250135172

Conselho Regional de Engenharia e Agronomia do MS

1. Responsável Técnico

RENATO RODRIGUES BORGES	RNP: 1008294713
Título Profissional: ENGENHEIRO MECÂNICO - ENGENHEIRO DE SEGURANÇA DO TRABALHO	Registro: GO1008294713
Empresa Contratada:	Registro:

2. Dados do Contrato

Contratante: ALFA SERVICE CONSULTORIA EMPRESARIAL LTDA	CPF/CNPJ: 57.413.969/0001-01	
Rua: RUA ACOTIPA	Bairro: ITAQUERA	Número: 65
Cidade: SÃO PAULO	UF: SP	País: Brasil
Contrato:	Celebrado em: 23/10/2025	CEP: 08.210-040
Valor: R\$ 2.000,00	Tipo de Contratante: PESSOA JURÍDICA	Vinculado à ART:
Ação Institucional:		

3. Dados Obra/Serviço

Logradouro	Bairro	Número	Complemento	Cidade	UF	País	Cep	Coordenada
RODOVIA 267	ZONA RURAL	SN	KM 35	BATAGUASSU	MS	BRA	79.780-000	
Data de Início: 23/10/2025		Previsão Término: 23/12/2026		Código:				
Tipo Proprietário: PESSOA JURÍDICA		Proprietário: MARFRIG GLOBAL FOODS		CPF/CNPJ: 03.853.896/0027-89				
Finalidade: INDUSTRIAL								

4. Atividades Técnicas

Supervisão	Quantidade	Unidade
Análise Prevenção e Controle de Riscos -> Gerenciamento e Controle de Riscos -> de controle de riscos	1,0000	unidade (un)
Inspeção Mecânica -> Sistemas Fluidodinâmicos -> de sistemas e redes	1,0000	unidade (un)
Inspeção Prevenção e Controle de Riscos -> Segurança em Redes e Tubulações de Fluidos, Gases e Vapores -> de segurança em redes e tubulações de fluidos, gases e vapores	2,0000	unidade (un)
Inspeção Prevenção e Controle de Riscos -> Segurança em Caldeiras e Vasos de Pressão -> de segurança em caldeiras e/ou vasos de pressão (NR13)	1,0000	unidade (un)

Após a conclusão das atividades técnicas o profissional deverá proceder a baixa desta ART

5. Observações

NR 12 - OPERAÇÃO DE MÁQUINAS NR 13 - CALDEIRAS E VASOS DE PRESSÃO NR 36 - ABATE E PROCESSAMENTO

6. Declarações

Cláusula Compromissória: qualquer conflito ou litígio originado do presente contrato, bem como sua interpretação ou execução, será resolvido por arbitragem, de acordo com a Lei nº. 9.307, de 23 de setembro de 1996, por meio de Centro de Mediação de Arbitragem - CMA vinculado ao CREA-MS, nos termos do respectivo regulamento de arbitragem que, expressamente, as partes declaram concordar.

Profissional

Contratante

Acessibilidade: Declaro atendimento às regras de acessibilidade previstas nas normas técnicas da ABNT, na legislação específica e no Decreto nº 5.296, de 2 de dezembro de 2004.

7. Entidade de Classe

8. Assinaturas

Declaro serem verdadeiras as informações acima.

Local _____ data _____

016.073.521-17 - RENATO RODRIGUES BORGES

57.413.969/0001-01 - ALFA SERVICE CONSULTORIA EMPRESARIAL LTDA

9. Informações

A ART é válida somente quando quitada, mediante apresentação do comprovante do pagamento ou conferência no site do Crea.
A autenticidade deste documento pode ser verificada no site www.creams.org.br ou www.confrea.org.br.
A guarda da via assinada da ART será de responsabilidade do profissional e do contratante com o objetivo de documentar o vínculo contratual.

www.creams.org.br / creams@creams.org.br
Tel: (67)3368-1000 / 0800-368-1000



CREA-MS
Conselho Regional de Engenharia e Agronomia do MS

Nosso Número: 140000000018309432

Valor ART: R\$ 103,03

Registrada em 24/10/2025

Valor Pago: R\$ 103,03

Documento assinado digitalmente

Documento assinado digitalmente



RENATO RODRIGUES BORGES
Data: 27/10/2025 15:00:39-0300
Verifique em <https://validar.it.gov.br>



GETULIO JOSE VIEIRA JUNIOR
Data: 30/10/2025 15:52:45-0300
Verifique em <https://validar.it.gov.br>



RELATÓRIO DE INSPEÇÃO SEGURANÇA PERIÓDICA

DOC Nº RIS202401007

EQUIPAMENTO:	SEPARADOR DE ÓLEO 01
TAG:	VP007
SETOR:	SALA DE MÁQUINAS

MARFRIG GLOBAL FOODS – BATAGUASSU- MS

NOVEMBRO – 2024

DADOS DE PLACA DO EQUIPAMENTO

Equipamento: Separador de óleo 01

Tipo de Equipamento: Horizontal

Modelo: HOS 36

Fabricante: JOHNSON CONTROLS

Fluido Principal: Amônia

Nº de Série: 367259

Categoria: II

Classe do Fluido: A

Grupo Potencial de Risco: 3

Pressão Máxima de Trabalho Admissível: 21,41 kgf/cm²

Pressão de teste hidrostático: 23,56 kgf/cm²

Volume Interno: 2,409 m³

Ano de Fabricação:

2021 **Código da inspeção:** VP007 INDUSTRIALIZADOS

Código de Projeto:

Asme VIII Divisão 01 – Ed 2019

RIS – RELATÓRIO DE INSPEÇÃO DE SEGURANÇA

LOCALIZAÇÃO

EMPRESA: MARFRIG GLOBAL FOODS
SETOR: INDUSTRIALIZADOS - UTILIDADES
ENDEREÇO: ROD. BR 267 KM 35 CEP 79.780-000
CIDADE: Bataguassu
BAIRRO: Zona Rural
ESTADO: Mato Grosso do Sul (MS)
CNPJ: 03.853.896/0027-89



TIPO DE INSPEÇÃO EXECUTADA

13.5.4.1 Os vasos de pressão devem ser submetidos a inspeções de segurança inicial, periódica e extraordinária.

INICIAL

PERIÓDICA

EXTRAORDINARIA

Procedimento de Inspeção Adotado:

- Análise de Conformidade da Documentação do Equipamento com a Norma Regulamentadora N° 13 M.T.E Portaria GM n° 3214 de 08 de junho de 1978, e suas respectivas portarias e atualizações.
- Condições físicas do vaso/ dispositivos de segurança.
- Exame visual externo: Identificação de defeitos físicos facilmente visíveis como trincas, alterações de acabamento superficial, soldas pobres etc.
- Análise da espessura das chapas e dispositivos de construção: Verificação da espessura das chapas que estruturam o equipamento por meio de medição ferromagnética.
- Análise em local de instalação do equipamento: Verificação direcionada para o local onde o equipamento se encontra instalado.

RIS – RELATÓRIO DE INSPEÇÃO DE SEGURANÇA

ANÁLISE DA DOCUMENTAÇÃO

Exigência Normativa NR 13.5.1.5	Status
Prontuário do Vaso de Pressão	SIM
Registro de Segurança	SIM
Comprovação documental de teste hidrostático	SIM
Projeto de Alteração ou Reparo	NÃO APLICÁVEL
Relatório de Inspeção	SIM
Certificados de Calibração dos Dispositivos de Segurança	SIM

RIS – RELATÓRIO DE INSPEÇÃO DE SEGURANÇA
VISTA FOTOGRÁFICA DO EQUIPAMENTO



RIS – RELATÓRIO DE INSPEÇÃO DE SEGURANÇA

EXAME VISUAL EXTERNO

INSPEÇÃO EXTERNA						
(A)APROVADO (R)REPROVADO		(NE)NÃO EXISTENTE		(NA)NÃO APLICÁVEL		
ITENS VERIFICADOS		A	R	NE	NA	OBSERVAÇÕES/COMENTÁRIOS
01	ALINHAMENTO	X				SEM OBSERVAÇÕES
02	PRUMO	X				
03	S.P.D.A	X				
04	BARREIRA DE CONTENÇÃO				X	
05	ESTRUTURAL PISO/FUNDAÇÃO	X				
06	SUPORTAÇÃO	X				
07	CHUMBADORES	X				
08	COSTADO	X				
09	TAMPOS	X				
10	BOCAIS	X				
11	PARAFUSOS/ESTOJOS/PORCAS	X				
12	JUNTAS PARAFUSADAS	X				
13	PLACA DE IDENTIFICAÇÃO	X				
14	NUMERO OU CODIGO DE IDENTIFICAÇÃO	X				
15	CATEGORIA	X				
16	SOLDAS DO COSTADO	X				
17	SOLDAS DOS TAMPOS	X				
18	SOLDAS DOS BOCAIS	X				
19	OUTRAS SOLDAS	X				
20	ISOLAMENTO EXTERNO				X	
21	VIBRAÇÕES	X				
22	VAZAMENTOS	X				
23	PINTURA	X				
24	VÁLVULAS DE BLOQUEIO	X				
25	DISPOSITIVO INDICADOR DE PRESSÃO INTERNA DO VASO	X				
26	MEDIDOR/VISOR DE NÍVEL				X	
27	PRESSOSTATO	X				
28	PURGADORES	X				
29	TERMÔMETRO	X				
30	DISPOSITIVO DE SEGURANÇA	X				

RIS – RELATÓRIO DE INSPEÇÃO DE SEGURANÇA

LAY OUT

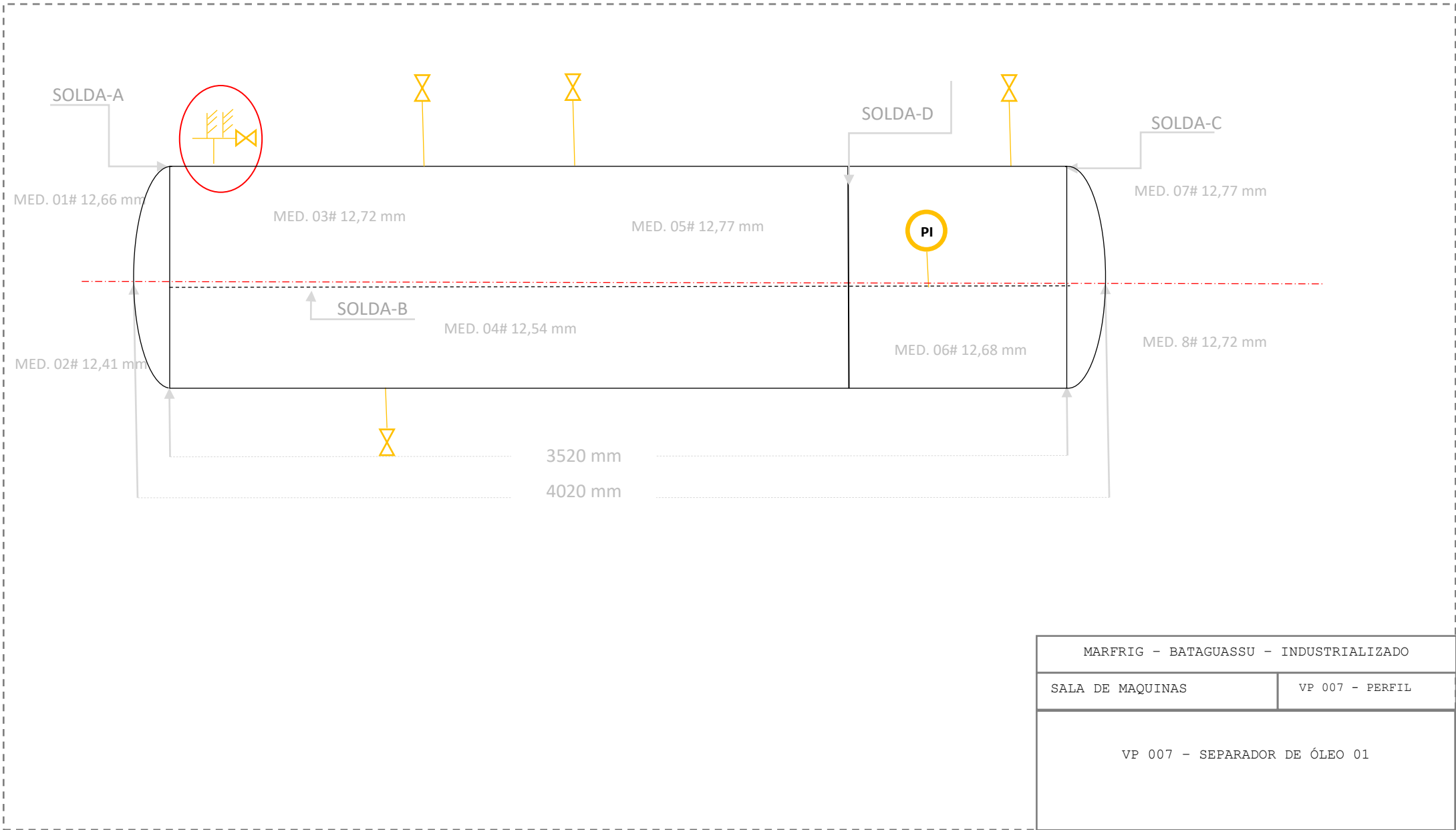

MARFRIG - BATAGUASSU - INDUSTRIALIZADO	
SALA DE MAQUINAS	VP 007 - PERFIL
VP 007 - SEPARADOR DE ÓLEO 01	



RIS – RELATÓRIO DE INSPEÇÃO DE SEGURANÇA

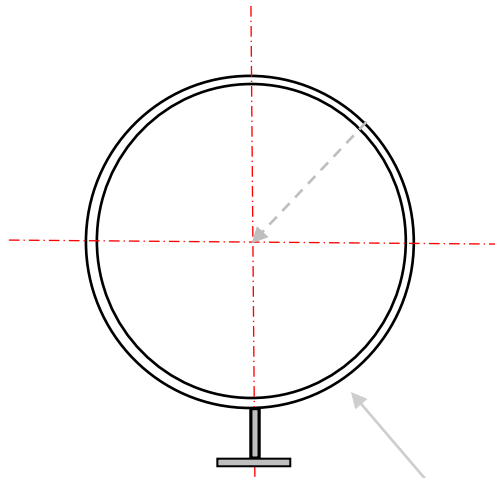

COSTADO

MATERIAL DA CHAPA DE AÇO

ASTM-A 516 17 70 ESPESSURA NOMINAL 12,72 mm

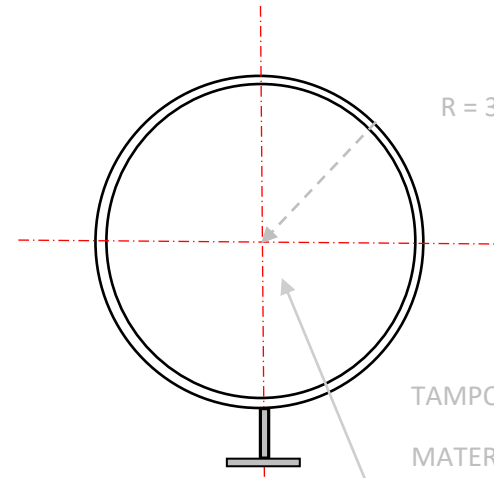

R = 375,00 mm

TAMPO

MATERIAL DA CHAPA DE AÇO

ASTM-A 516 17 70 ESPESSURA NOMINAL 12,72 mm

MARFRIG - BATAGUASSU - INDUSTRIALIZADO

SALA DE MAQUINAS

VP 007 - PERFIL

VP 007 - SEPARADOR DE ÓLEO 01

RIS – RELATÓRIO DE INSPEÇÃO DE SEGURANÇA

Tabela de leituras

Ponto	Espessura Nominal	Espessura Mínima	Espessura Medida
MED.01	12,72 mm	7,20 mm	12,66 mm
MED.02	12,72 mm	7,20 mm	12,41 mm
MED.03	12,72 mm	8,24 mm	12,72 mm
MED.04	12,72 mm	8,24 mm	12,54 mm
MED.05	12,72 mm	8,24 mm	12,77 mm
MED.06	12,72 mm	8,24 mm	12,68 mm
MED.07	12,72 mm	7,20 mm	12,77 mm
MED.08	12,72 mm	7,20 mm	12,72 mm

EQUIPAMENTO UTILIZADO PARA DADOS DA ESPESSURA DE CHAPA:

MEDIDOR DE ESPESSURA POR ULTRASSOM

FABRICANTE: METROTOKYO MODELO: MTK-1310 NEW

FAIXA DE MEDIÇÃO: 0.001 mm - 225 mm

ACCURACY: +- (1%H=0,1) mm

MENOR MEDIÇÃO: 0,01 mm

DISPOSITIVO DE ALIVIO E SEGURANÇA

OPERANTE

INOPERANTE



DISPOSITIVO DE SEGURANÇA INSTALADO NO VASO DE PRESSÃO

TIPO DE DISPOSITIVO		VALVULA DE SEGURANÇA	
FABRICANTE		DANFFOS	
IDENTIFICAÇÃO		PSV-SO-01 A	
CONEXÃO ENTRADA	3/4"	CONEXÃO SAÍDA	1"
PRESSÃO DE ABERTURA		18,0kgf/cm ²	
DATA DA CALIBRAÇÃO		04/02/2024	

DISPOSITIVO DE SEGURANÇA INSTALADO NO VASO DE PRESSÃO

TIPO DE DISPOSITIVO		VALVULA DE SEGURANÇA	
FABRICANTE		DANFFOS	
IDENTIFICAÇÃO		PSV-SO-01B	
CONEXÃO ENTRADA	3/4"	CONEXÃO ENTRADA	1"
PRESSÃO DE ABERTURA		18,0kgf/cm ²	
DATA DA CALIBRAÇÃO		04/02/2024	

DISPOSITIVO DE LEITURA DA PRESSÃO

OPERANTE

INOPERANTE



DISPOSITIVO DE LEITURA DE PRESSÃO INSTALADO NO VASO DE PRESSÃO			
TIPO DE DISPOSITIVO		MANOVACUÔMETRO	
FABRICANTE		WILLY	
IDENTIFICAÇÃO		PI-SO-01	
CONEXÃO ENTRADA	1/2	CONEXÃO SAÍDA	5"
ESCALA		-1 á 21 kgf/cm ²	
DATA DA CALIBRAÇÃO		02/02/2024	

RIS – RELATÓRIO DE INSPEÇÃO DE SEGURANÇA

PLACA DE IDENTIFICAÇÃO DO VASO

EQUIPAMENTO		SEPARADOR DE OLEO HORIZONTAL		
MODELO	HDS-36	DATA DE FABR.	2021	
NUMERO DE SERIE	367259	TAG	---	
FLUIDO	CASCO	TUBOS/ SERPENTINA	NORMA REFERENCIA	
VOLUME INTERNO	m ³	2,409	---	ASME VIII DIV.1 ED. 2019
PMTA / PRESSÃO PROJETO	bar(g)	21	---	
PRESSÃO DE TESTE	bar(g) PMEU	23,1	---	
TEMPERATURA DE PROJETO	°C	-29/120	---	CATEGORIA N° 3-13
MARGEM PARA CORROSÃO	mm	0	---	A-3-II
EFICIÊNCIA DE SOLDA		0,7	---	PESO VAZIO (kgf)
ALÍVIO DE TENSÃO		NÃO	---	2050

DES. Nº 2318C116

ANÁLISE DO LOCAL DE INSTALAÇÃO DO EQUIPAMENTO

Requisitos de Instalação do Vaso de Pressão NR 13 Item 13.5.2.2	Existência dos requisitos citados
Disponer de pelo menos 2 (duas) saídas amplas, permanentemente desobstruídas, sinalizadas e dispostas em direções distintas;	SIM
Disponer de acesso fácil e seguro para as atividades de manutenção, operação e inspeção, sendo que, para guarda corpos vazados, os vãos devem ter dimensões que impeçam a queda de pessoas;	SIM
Disponer de ventilação permanente com entradas de ar que não possam ser bloqueadas;	SIM
Disponer de iluminação conforme normas oficiais vigentes;	SIM
Possuir sistema de iluminação de emergência.	SIM

DATA DE REALIZAÇÃO DA INSPEÇÃO

INICIO: 25/11 /2024

TÉRMINO: 25/11/2024

PARECER TÉCNICO

De acordo com as inspeções e aferimentos citados acima o equipamento está **apto** a operar dentro das condições de projeto exceto se existir possíveis alterações sem a prévia comunicação ao inspetor responsável citado neste relatório.

RIS – RELATÓRIO DE INSPEÇÃO DE SEGURANÇA

PRÓXIMA INSPEÇÃO

NR 13 Item 13.4.5 alínea “a”

Categoria do Vaso	Exame Externo	Exame Interno
I	1 ano	3 anos
II	2 anos	4 anos
III	3 anos	6 anos
IV	4 anos	8 anos
V	5 anos	10 anos

Portanto fica estabelecido que a próxima inspeção periódica do vaso deve ser realizada até a data:

MÊS

NOVEMBRO

ANO

2026

RECOMENDAÇÕES GERAIS

1. Manter operadores treinados de acordo com o anexo 01 da NR 13.
2. Manter plano de manutenção preventiva do vaso.

Responsabilidade Técnica
Alfa Service Eireli - ME
21.006.932/0001-11

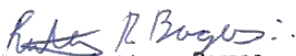

ART - Supervisão/Coordenação
Renato Rodrigues Borges
Engenheiro Mecânico
Crea 1008294713D-GO
RNP: 1008294713

Renato Rodrigues Borges
Eng. Mecânico
CREA: 1008294713D-GO

Bataguassu, 27 de Novembro de 2024

ANEXO 01- EQUIPAMENTO PADRÃO

Laboratório de Metrologia

Certificado de Calibração**0550-2763**

Pag. 01/01

1- CONTRATANTE: ALFA SERVICE EIRELI
ENDEREÇO: Rua Nicanor de Faria, SN - Quadra 21, lote 15, piso 1 - Itaberai/GO
SOLICITANTE: O mesmo
ENDEREÇO: O mesmo

2- INSTRUMENTO: MEDIDOR DE ESPESSURA POR ULTRASSOM **Número de Série:** H21569637
Marca: Metrotokyo **Faixa de Medição:** 1,0 à 225 mm
Modelo / Código: MTK-1310 NEW **Menor Divisão:** 0,01 / 0,1 mm
Identificação: Não Consta **Ordem de Serviço:** 0550/27

3- Procedimento de Calibração:
 A realização da calibração foi baseada em nosso procedimento interno: QPCA-066 Rev.: 01 o qual possui referências as normas aplicáveis e vigentes ao instrumento supra citado.

4- Padrão(ões) de Referência Utilizado(s):

DESCRIÇÃO	IDENTIFICAÇÃO	CERTIFICADO Nº	ÓRGÃO CALIBRADOR	VALIDO ATÉ
Jogo de Blocos Padrão	MTK-10 A e MTK-10 B	859/22	LAB CAL 0158	08/2025

5- Resultados (mm) :

GRANDEZA DIMENSIONAL						
Indicação no Padrão	Indicação no instrumento	Erro Sistemático	Incerteza (\pm)	Erro Total	Critério Cliente	Situação
1,0	1,13	0,13	0,01	0,14	-	-
3,0	3,00	0,00	0,01	0,01	-	-
6,0	6,05	0,05	0,01	0,06	-	-
10,0	10,05	0,05	0,01	0,06	-	-
15,0	15,02	0,02	0,01	0,03	-	-
20,0	20,05	0,05	0,01	0,06	-	-
30,0	30,01	0,01	0,01	0,02	-	-
40,0	40,08	0,08	0,01	0,09	-	-
50,0	50,09	0,09	0,01	0,10	-	-
60,0	60,01	0,01	0,01	0,02	-	-
80,0	79,99	-0,01	0,01	0,02	-	-
100,00	100,00	0,00	0,01	0,01	-	-

6- Incerteza de Medição: Conforme Tabela Acima:

"A incerteza declarada é baseada em uma incerteza padronizada combinada multiplicada por um fator de abrangência $k = 2,00$ para nível de confiança de aproximadamente 95%."

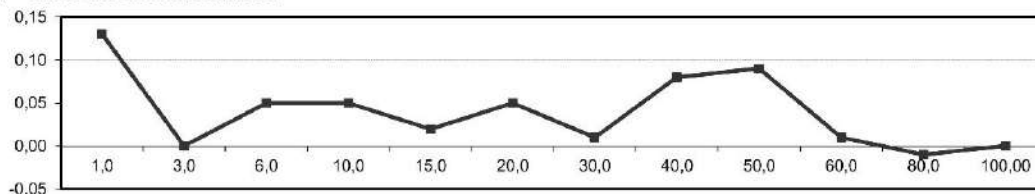
7- Gráfico dos Erros Sistemáticos:**8- Condições Ambientais Durante a Calibração:**

Temperatura: 20 ± 1 °C Umidade relativa do ar: < 80 %UR

9- Outras Informações:

Local da Calibração: Metrotokyo Solicitante
 Data de Recebimento: 10/05/24
 Data da Calibração: 10/05/24
 Próxima Calibração: 05/2025

Eduardo Kalinichenko
 Eduardo Kalinichenko
 Responsável Técnico

Este certificado é válido exclusivamente para o objeto verificado, não sendo extensivo a quaisquer lotes, mesmo que similares. Sua reprodução só poderá ser total e depende da aprovação por escrito deste laboratório.